

LOC		DIST		REVISIONS			
AD	00	REV	LTR	DESCRIPTION	DATE	OWN	APVD
		J2		ECO-07-027490	26DEC2007	RB	JO
		J3		REVISED PER ECO-09-021510	14SEP09	KK	AEG

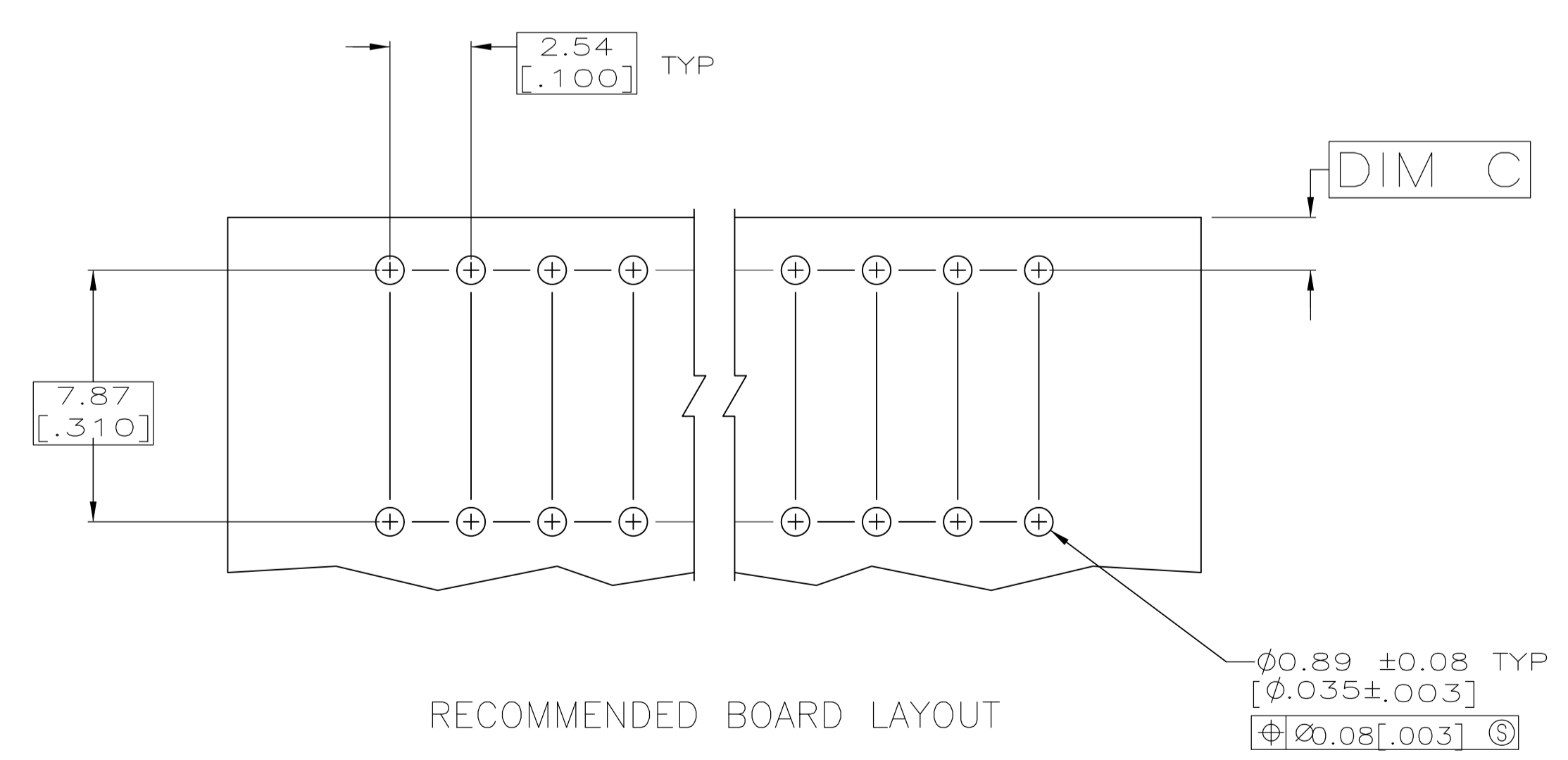
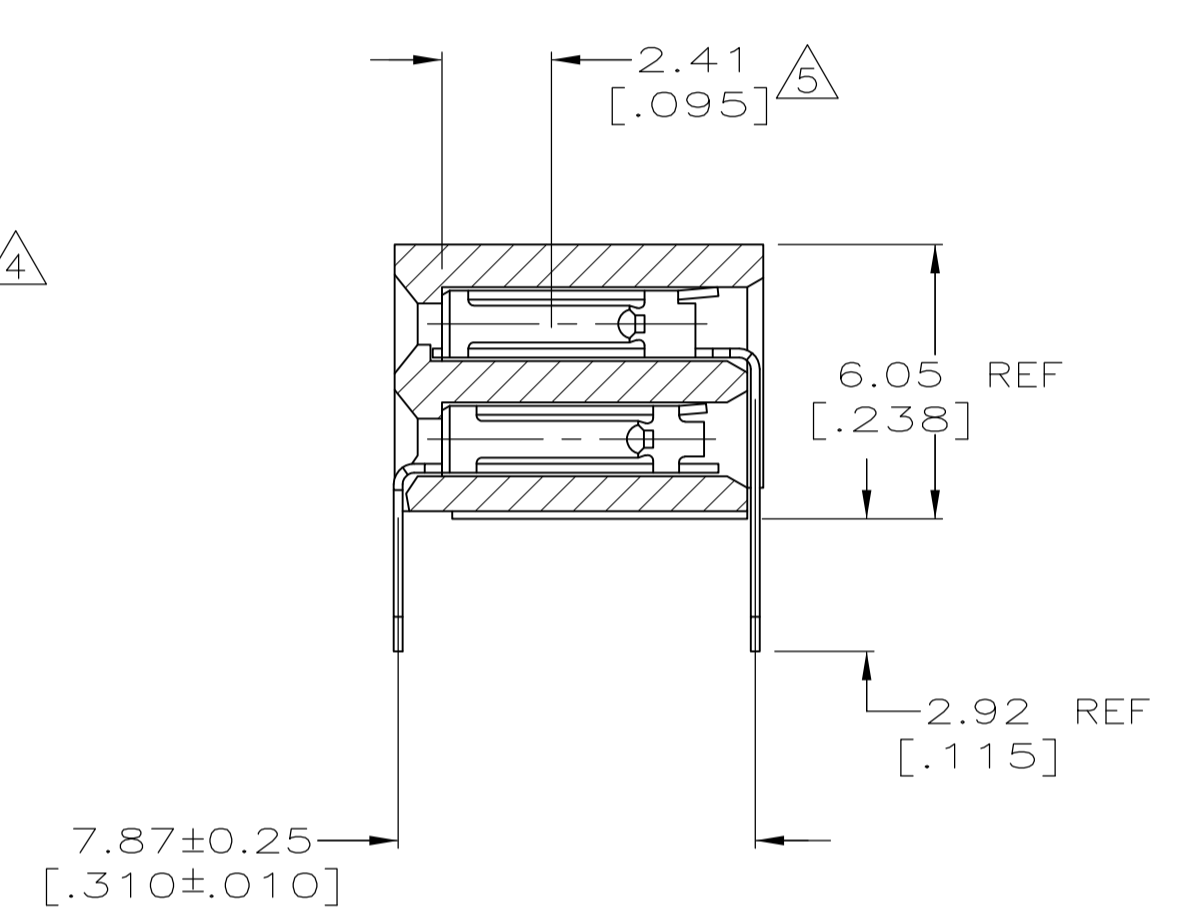
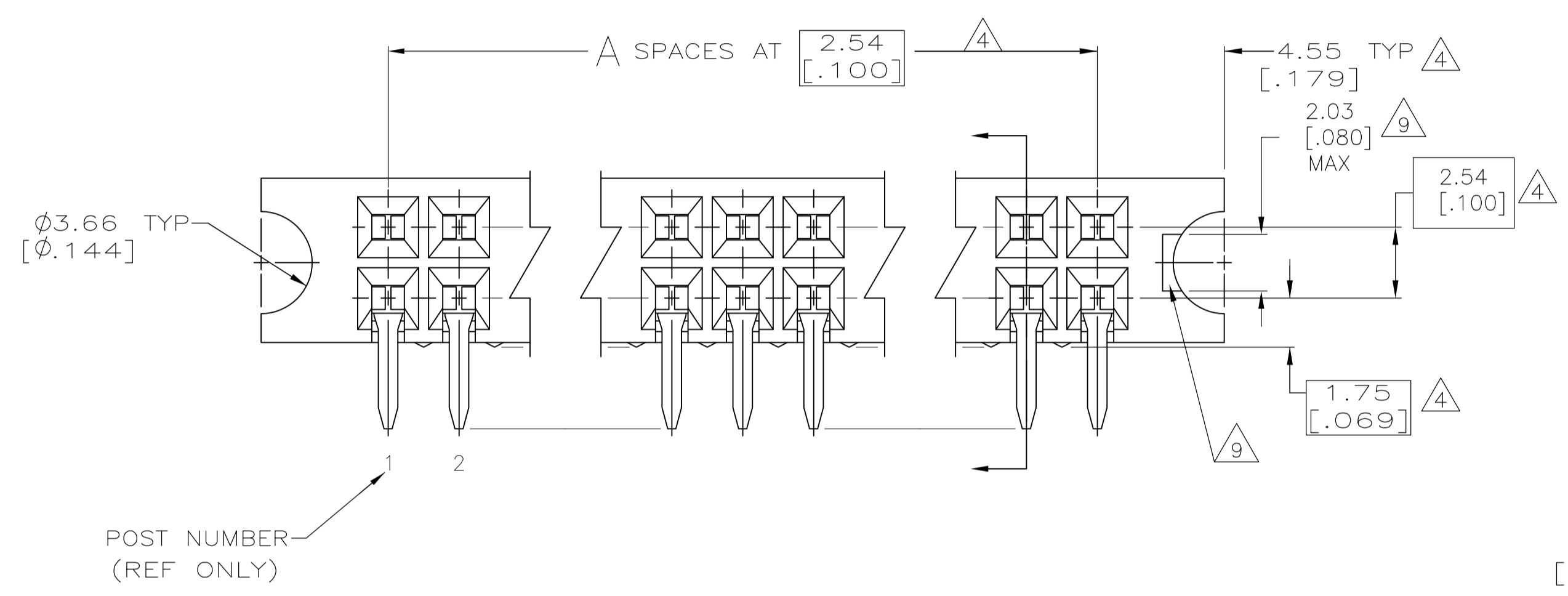
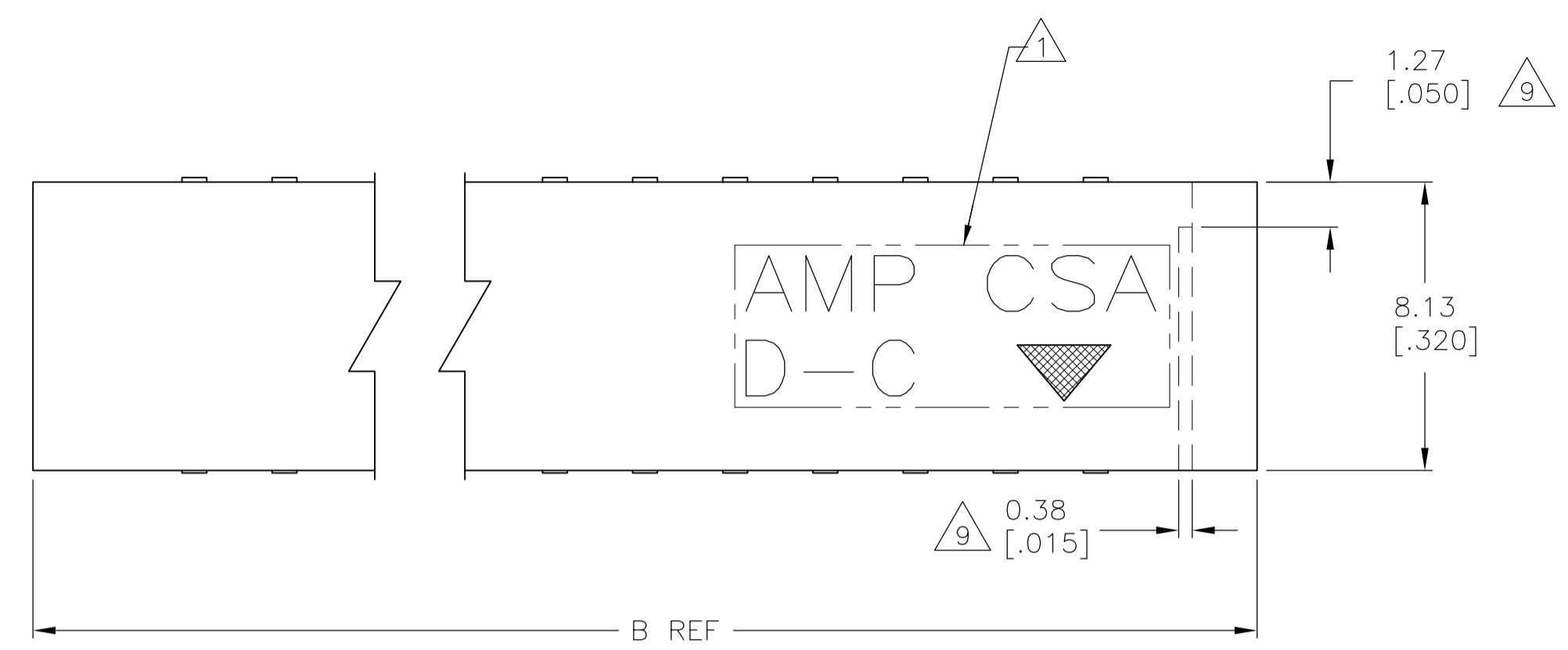

- 1 HOUSING: 1-70 POSITION SIZES MAY BE PPS, GLASS-FILLED OR PCT, GLASS-FILLED. POSITION SIZES GREATER THAN 70 WILL BE PPS, GLASS-FILLED.
- 2 CONTACT: PHOSPHOR BRONZE
- 3 CONTACT FINISH: DUPLEX PLATING - 0.00076[.000030] GOLD IN CONTACT AREA, 0.00127-0.00254[.000050-.000100] BRIGHT TIN-LEAD ON SOLDER LEADS ALL OVER 0.00127[.000050] NICKEL
- 4 THESE DIMENSIONS PERTAIN TO CAVITY CENTERLINES ONLY
- 5 POINT-OF-MEASUREMENT FOR PLATING THICKNESS (MEASURED INSIDE CONTACT BEAMS)
- 6 "AMP", "CSA", "▼" AND "DATE CODE" WITH .062 ±0.15 HIGH CHARACTERS WHERE SIZE PERMITS.
- 7 CONTACT FINISH: DUPLEX PLATING - 0.00076[.000030] GOLD IN CONTACT AREA, 0.00127-0.00254[.000050-.000100] MATTE TIN ON SOLDER LEADS ALL OVER 0.00127[.000050] NICKEL
- 8 ROHS 2002/95/EC COMPLIANT.
- 9 RECESSED AREA AROUND MOLD GATE IS OPTIONAL. THIS FEATURE IS ALLOWABLE ON EITHER SIDE OF HOUSING OR MAY NOT BE PRESENT AT ALL.
- 10 OBSOLETE PARTS: OBSOLETE CIS STREAMLINING PER D.RENAUD/D.SINISI

FINISH	POST NUMBER OMITTED		C	B	A	NO OF POSN	PART NUMBER
	ROW M	ROW N					
7	29,32	29,32	2.54 [.100]	95.45 [3.758]	34	66-70	8 5-535604-2
7	4,6	4,6	1.65 [.065]	49.73 [1.958]	16	30-34	8 5-535604-1
3	29,32	29,32	2.54 [.100]	95.45 [3.758]	34	66-70	535604-2
3	4,6	4,6	1.65 [.065]	49.73 [1.958]	16	30-34	535604-1

THIS DRAWING IS A CONTROLLED DOCUMENT.

DIMENSIONS: mm [INCHES]	TOLERANCES UNLESS OTHERWISE SPECIFIED:	DWG: KATE HELM 11/26/91	CHK: DOUG SARVER 12/18/91	Tyco Electronics Corporation Harrisburg, PA 17105-3608
0 PLC ± -	1 PLC ± -	2 PLC ± -	3 PLC ± 0.13[.005]	4 PLC ± -
MATERIAL	FINISH SEE TABLE	WEIGHT	SIZE: A1	CAGE CODE: 00779
CUSTOMER DRAWING		SCALE: 6:1	SHEET: 1 OF 1	REV: J3

RCPT ASSY,MOD II,DBL-ROW,100CL CLSD-ENTRY,W/GUIDE PIN EARS,SELECT LOAD & EXTRA SHORT PT-OF-CONTACT