

Evaluation Board for Dual High Speed Op Amps Offered in 16-Lead 3 mm × 3 mm LFCSP

FEATURES

- Enables quick breadboarding/prototyping**
- User-defined circuit configuration**
- Edge-mounted SMA connector provisions**
- Easy connection to test equipment and other circuits**
- RoHS compliant**

GENERAL DESCRIPTION

The Analog Devices, Inc., 16-lead LFCSP evaluation board is designed to help users evaluate dual high speed op amps offered in 16-lead, 3 mm × 3 mm LFCSP packages. The evaluation board is a bare board (that is, there are no components or amplifier soldered to the board; these must be ordered separately) that enables users to quickly prototype a variety of dual op amp circuits, which minimizes risk and

reduces time to market. Figure 1 and Figure 2 show the bare evaluation board component and circuit sides.

The evaluation board is a 2-layer PCB that accepts SMA edge mounted connectors on the inputs and outputs for efficient connection to test equipment or other circuitry. The ground plane, component placement, and supply bypassing are designed to minimize parasitic inductances and capacitances. The evaluation board components are primarily SMT 0805 case size, with the exception of the electrolytic bypass capacitors (C1 and C2), which are 3528 case size.

Figure 3 shows the evaluation board schematic. The evaluation board assembly drawings and layout patterns are shown in Figure 4 through Figure 7.

EVALUATION BOARD COMPONENT AND CIRCUIT SIDES

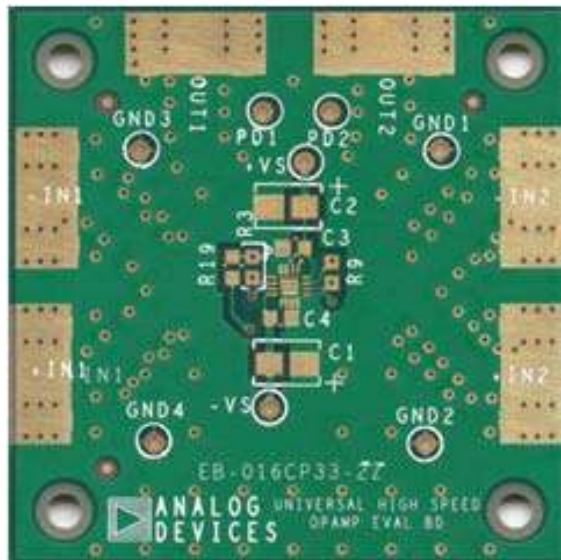

NOTES
1. THE EVALUATION BOARD SILKSCREEN PART NUMBER LABELING ON YOUR BOARD MAY BE DIFFERENT FROM WHAT IS SHOWN HERE.

Figure 1. Component Side of Evaluation Board

08145-101

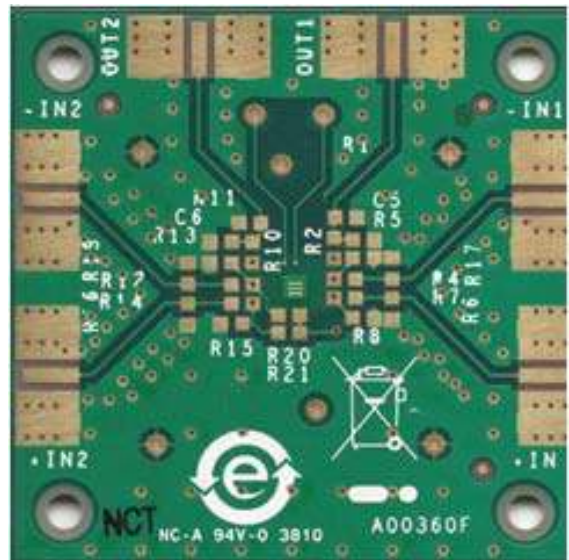

NOTES
1. THE EVALUATION BOARD SILKSCREEN PART NUMBER LABELING ON YOUR BOARD MAY BE DIFFERENT FROM WHAT IS SHOWN HERE.

Figure 2. Circuit Side of Evaluation Board

08145-102

TABLE OF CONTENTS

Features	1	Evaluation Board Schematics, Assembly Drawings and Layout Patterns	3
General Description	1	Ordering Information.....	6
Evaluation Board Component and Circuit Sides	1	Bill of Materials.....	6
Revision History	2		

REVISION HISTORY

6/11—Rev. 0 to Rev. A

Changes to Features and General Descriptions Sections	1
Changes to Figure 1	1
Added Figure 2.....	1
Changes to Evaluation Board Schematic, Assembly Drawings, and Layout Patterns.....	3
Added Ordering Information Section	6

2/10—Revision 0: Initial Version

EVALUATION BOARD SCHEMATICS, ASSEMBLY DRAWINGS AND LAYOUT PATTERNS

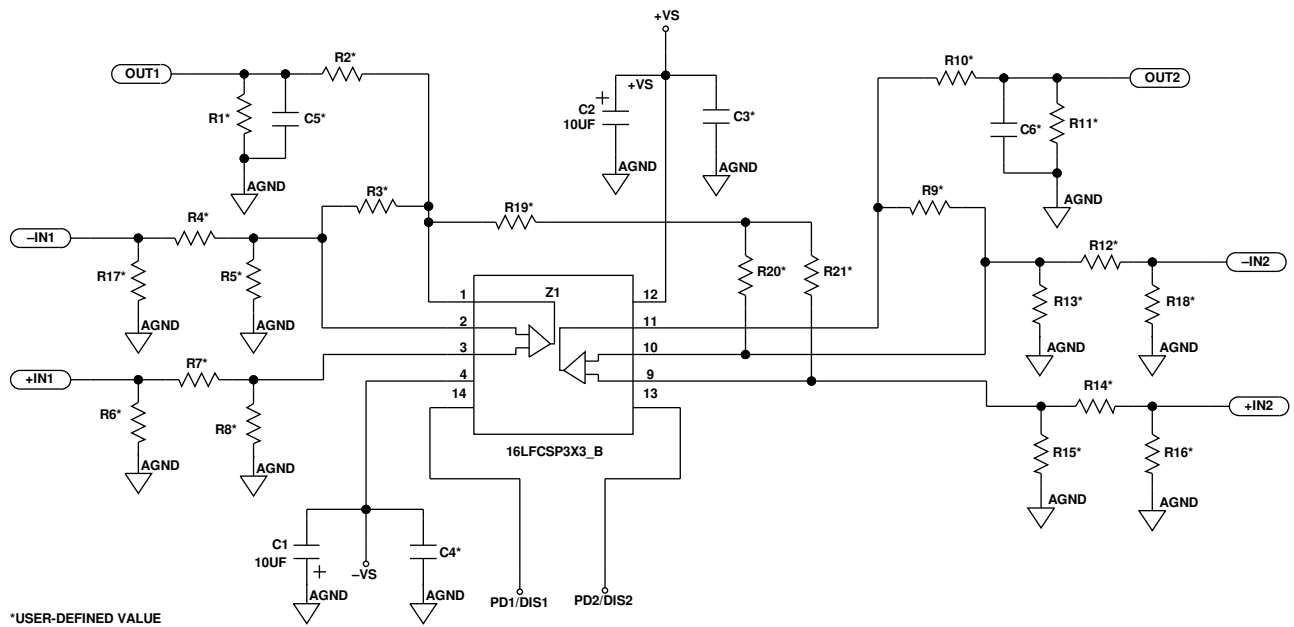
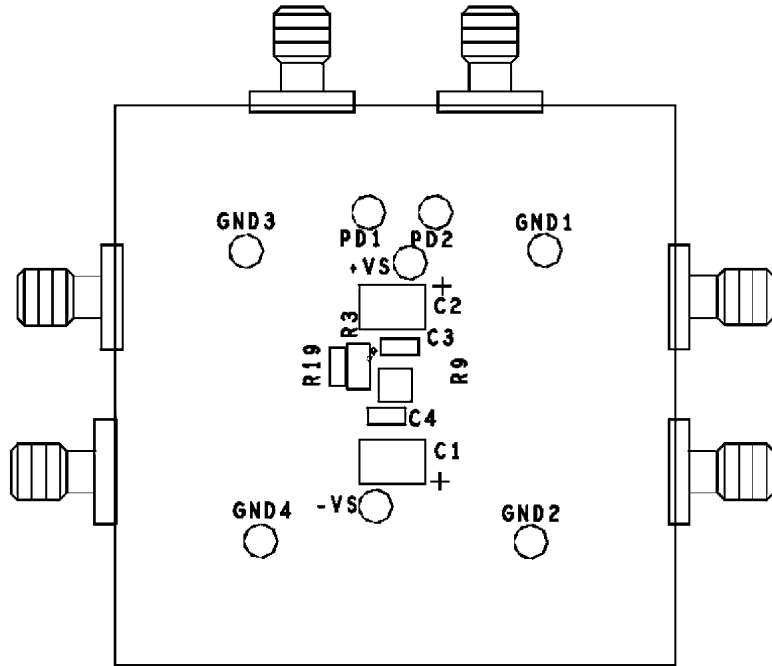

Figure 3. Evaluation Board Schematic

08145-001



08145-104

Figure 4. Assembly Drawing, Component Side

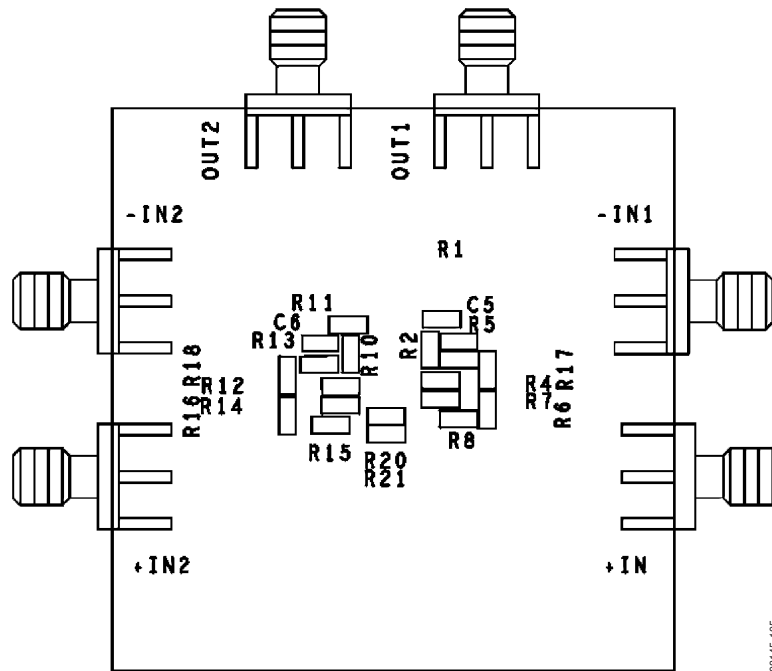

08145-105

Figure 5. Assembly Drawing, Circuit Side

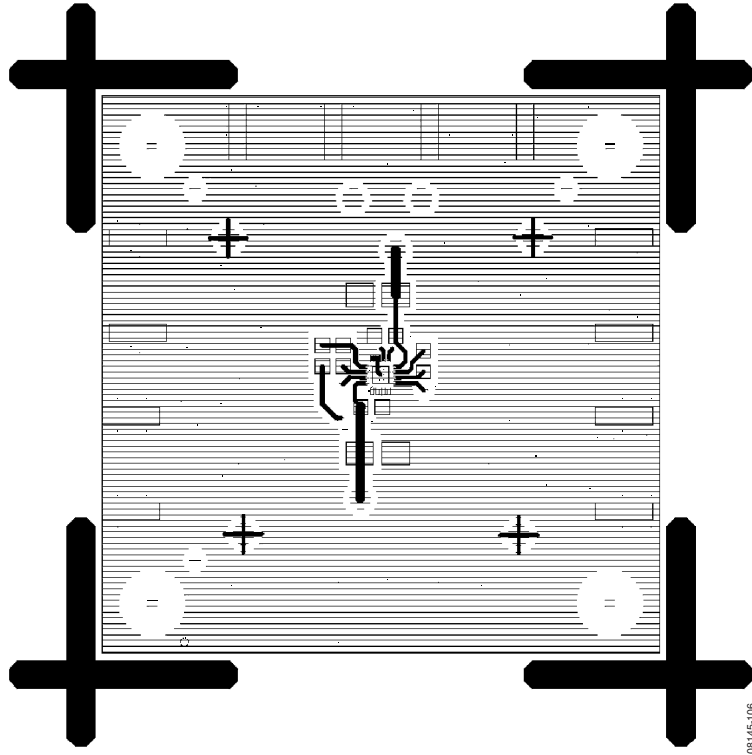

Figure 6. Layout Pattern, Component Side

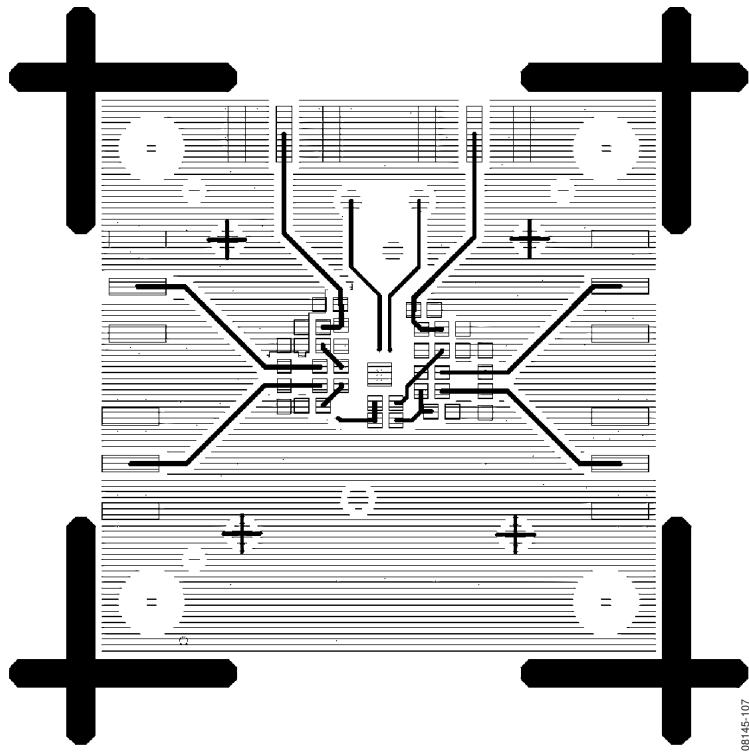

Figure 7. Layout Pattern, Circuit Side

ORDERING INFORMATION**BILL OF MATERIALS**

Table 1.

Quantity	Reference Designator	Description	Package
8	+VS, -VS, GND1, GND2, GND3, GND4, PD1, PD2	Test point	TP
2	C1, C2	10 μ F capacitor	3528
4	C3, C4, C5, C6	Capacitor, user defined	C0805
1	DUT	DEV, QFN16_3x3	16-lead LFCSP
6	+IN1, +IN2, -IN1, -IN2, OUT1, OUT2	SMA/SMT	SMA/SMT
21	R1 to R21	Resistor, user defined	R0805

NOTES

NOTES

**ESD Caution**

ESD (electrostatic discharge) sensitive device. Charged devices and circuit boards can discharge without detection. Although this product features patented or proprietary protection circuitry, damage may occur on devices subjected to high energy ESD. Therefore, proper ESD precautions should be taken to avoid performance degradation or loss of functionality.

Legal Terms and Conditions

By using the evaluation board discussed herein (together with any tools, components documentation or support materials, the "Evaluation Board"), you are agreeing to be bound by the terms and conditions set forth below ("Agreement") unless you have purchased the Evaluation Board, in which case the Analog Devices Standard Terms and Conditions of Sale shall govern. Do not use the Evaluation Board until you have read and agreed to the Agreement. Your use of the Evaluation Board shall signify your acceptance of the Agreement. This Agreement is made by and between you ("Customer") and Analog Devices, Inc. ("ADI"), with its principal place of business at One Technology Way, Norwood, MA 02062, USA. Subject to the terms and conditions of the Agreement, ADI hereby grants to Customer a free, limited, personal, temporary, non-exclusive, non-sublicensable, non-transferable license to use the Evaluation Board FOR EVALUATION PURPOSES ONLY. Customer understands and agrees that the Evaluation Board is provided for the sole and exclusive purpose referenced above, and agrees not to use the Evaluation Board for any other purpose. Furthermore, the license granted is expressly made subject to the following additional limitations: Customer shall not (i) rent, lease, display, sell, transfer, assign, sublicense, or distribute the Evaluation Board; and (ii) permit any Third Party to access the Evaluation Board. As used herein, the term "Third Party" includes any entity other than ADI, Customer, their employees, affiliates and in-house consultants. The Evaluation Board is NOT sold to Customer; all rights not expressly granted herein, including ownership of the Evaluation Board, are reserved by ADI. CONFIDENTIALITY. This Agreement and the Evaluation Board shall all be considered the confidential and proprietary information of ADI. Customer may not disclose or transfer any portion of the Evaluation Board to any other party for any reason. Upon discontinuation of use of the Evaluation Board or termination of this Agreement, Customer agrees to promptly return the Evaluation Board to ADI. ADDITIONAL RESTRICTIONS. Customer may not disassemble, decompile or reverse engineer chips on the Evaluation Board. Customer shall inform ADI of any occurred damages or any modifications or alterations it makes to the Evaluation Board, including but not limited to soldering or any other activity that affects the material content of the Evaluation Board. Modifications to the Evaluation Board must comply with applicable law, including but not limited to the RoHS Directive. TERMINATION. ADI may terminate this Agreement at any time upon giving written notice to Customer. Customer agrees to return to ADI the Evaluation Board at that time. LIMITATION OF LIABILITY. THE EVALUATION BOARD PROVIDED HEREUNDER IS PROVIDED "AS IS" AND ADI MAKES NO WARRANTIES OR REPRESENTATIONS OF ANY KIND WITH RESPECT TO IT. ADI SPECIFICALLY DISCLAIMS ANY REPRESENTATIONS, ENDORSEMENTS, GUARANTEES, OR WARRANTIES, EXPRESS OR IMPLIED, RELATED TO THE EVALUATION BOARD INCLUDING, BUT NOT LIMITED TO, THE IMPLIED WARRANTY OF MERCHANTABILITY, TITLE, FITNESS FOR A PARTICULAR PURPOSE OR NON-INFRINGEMENT OF INTELLECTUAL PROPERTY RIGHTS. IN NO EVENT WILL ADI AND ITS LICENSORS BE LIABLE FOR ANY INCIDENTAL, SPECIAL, INDIRECT, OR CONSEQUENTIAL DAMAGES RESULTING FROM CUSTOMER'S POSSESSION OR USE OF THE EVALUATION BOARD, INCLUDING BUT NOT LIMITED TO LOST PROFITS, DELAY COSTS, LABOR COSTS OR LOSS OF GOODWILL. ADI'S TOTAL LIABILITY FROM ANY AND ALL CAUSES SHALL BE LIMITED TO THE AMOUNT OF ONE HUNDRED US DOLLARS (\$100.00). EXPORT. Customer agrees that it will not directly or indirectly export the Evaluation Board to another country, and that it will comply with all applicable United States federal laws and regulations relating to exports. GOVERNING LAW. This Agreement shall be governed by and construed in accordance with the substantive laws of the Commonwealth of Massachusetts (excluding conflict of law rules). Any legal action regarding this Agreement will be heard in the state or federal courts having jurisdiction in Suffolk County, Massachusetts, and Customer hereby submits to the personal jurisdiction and venue of such courts. The United Nations Convention on Contracts for the International Sale of Goods shall not apply to this Agreement and is expressly disclaimed.