

Digitally controlled LED driver board for automotive lighting applications

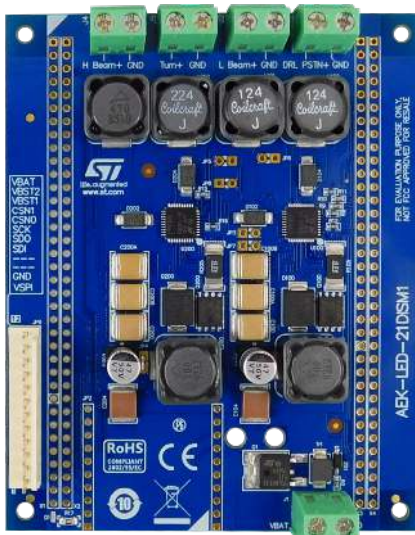

Features

- Two embedded L99LD21 high power LED drivers able to supply four independent channels
- Output current up to 1.69 A each channel
- Input operating voltage range from 5.5 V to 24 V
- Programmable via SPI, allowing accurate LED current setting
- Protections and diagnostics for output short-circuit and open-load, overtemperature, and battery undervoltage.
- Automotive Limp-Home Mode support
- Board size: 81 x 100 mm. Maximum components height: 11 mm
- WEEE and RoHS compliant
- All ST components are qualified Automotive grade
- Board designed according to the AutoDevKit initiative

Description

The **AEK-LED-21DISM1** LED driver board is designed for high brightness automotive LED front lighting applications according to the AutoDevKit initiative. It can control four LED strings through two embedded **L99LD21** flexible LED drivers with high efficiency boost controller and two embedded buck converters.

The boost controller section in each **L99LD21** LED driver integrates a high current gate driver for an external N-channel MOSFET and delivers a constant output voltage to two integrated buck converters. The boost controller of two devices can be stacked to allow dual phase operation for high power applications, with an interleaving pattern for improved input current ripple and current load sharing. The buck converter integrates an N-channel MOSFET driven by a bootstrap circuit.

The board uses SPI communication with an external microcontroller via a 12-pin male connector, and a special Limp Home Mode implemented in the L99LD21 driver ensures that active communication with the MCU is regularly monitored. You can use the AutoDevKit library extension for the SPC5-Studio development environment to install board firmware drivers that are immediately compatible with SPC5-family MCUs.

The overall package is designed to address automotive lighting applications, including high beams and low beams, daytime running lights, turn indicators, position lights, side markers and fog lights.



Product summary

AutoDevKit digitally controlled LED driver board	AEK-LED-21DISM1
high power LED driver for automotive applications	L99LD21
Development environment	SPC5-Studio addon for Eclipse (with AutoDevKit plugin extension)
Suggested microcontroller	SPC5 family MCUs
Application scenario	Automotive LED lighting

1 Overview

The **AEK-LED-21DISM1** evaluation board is designed to replicate a typical automotive front lighting solution. Boost gate switching and buck converter current control is managed by the digital logic and control section of the **L99LD21** LED driver, which also provides other safety and protection mechanisms, including standby management through a dedicated state machine and a special Limp Home safety mode to help preserve fail safe operation for safety critical operations like low beams and turn indicators.

Figure 1. AEK-LED-21DISM1 block diagram

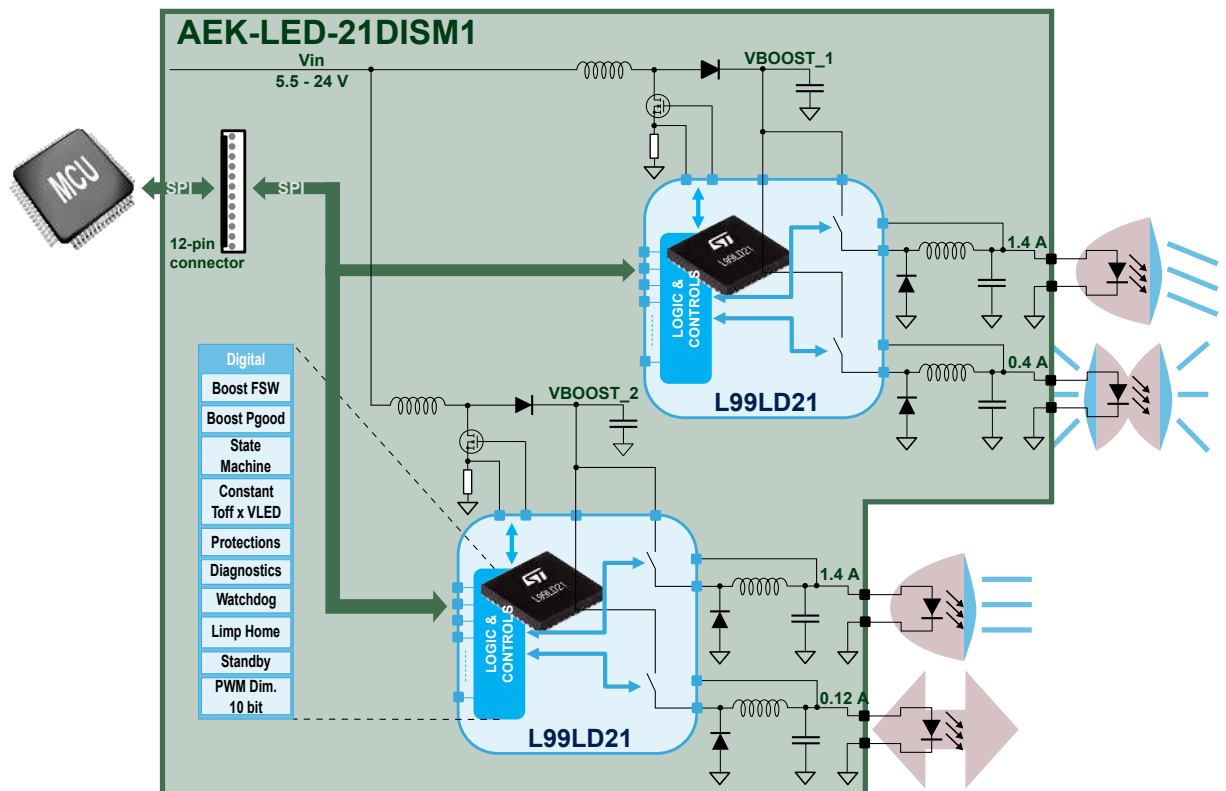

The behavior of the board is monitored and controlled through the control, status and customer trimming registers in the **L99LD21** LED drivers, which can be read or set by an external microcontroller through the fast SPI interface.

RELATED LINKS

[AutoDevKit: Adaptive Front Lighting demonstration kit video on YouTube](#)

2 Schematic diagrams

Figure 2. AEK-LED-21DISM1 schematic - LED section

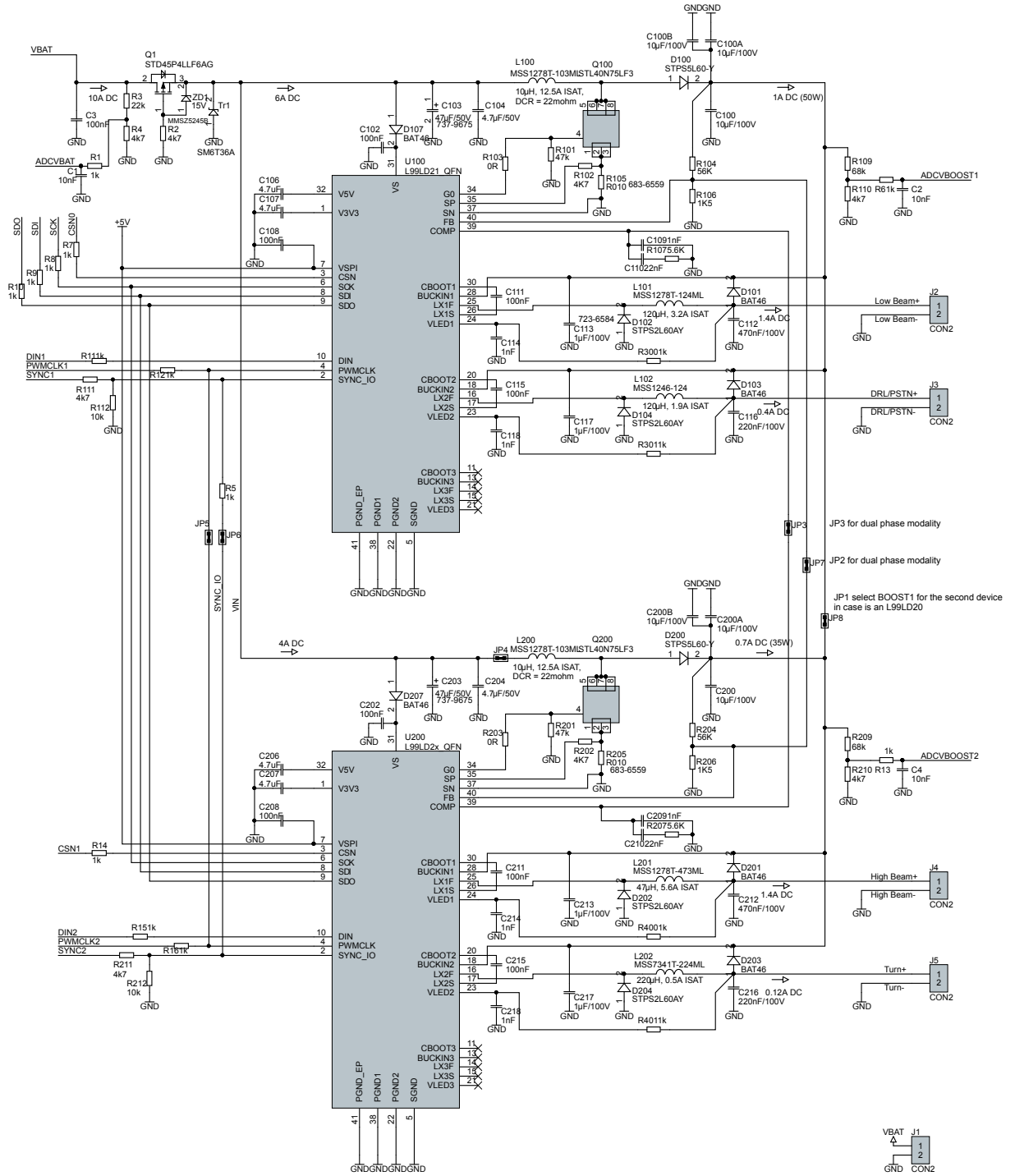
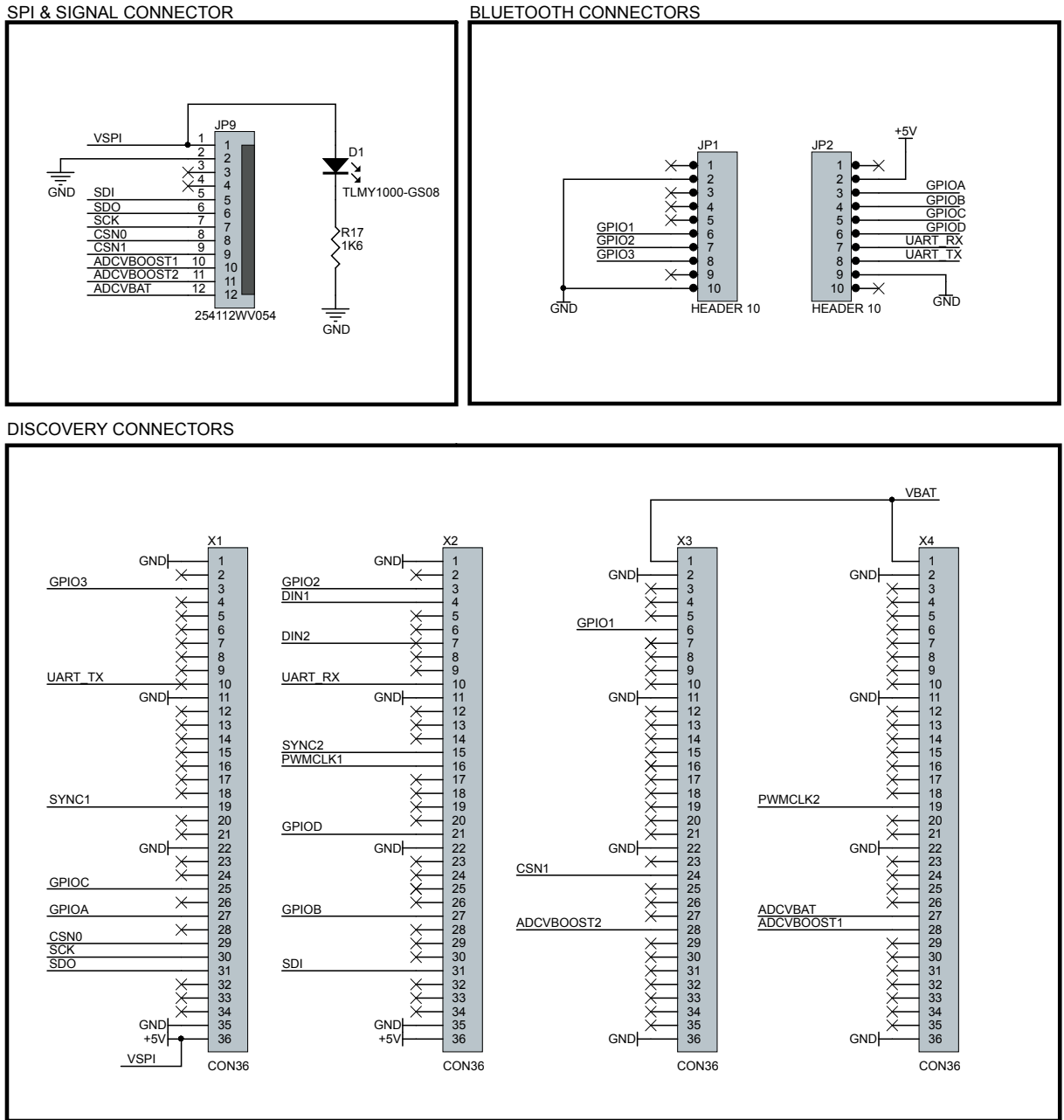

Figure 3. AEK-LED-21DISM1 schematic connectors



Revision history

Table 1. Document revision history

Date	Version	Changes
26-Jul-2019	1	Initial release.

IMPORTANT NOTICE – PLEASE READ CAREFULLY

STMicroelectronics NV and its subsidiaries (“ST”) reserve the right to make changes, corrections, enhancements, modifications, and improvements to ST products and/or to this document at any time without notice. Purchasers should obtain the latest relevant information on ST products before placing orders. ST products are sold pursuant to ST’s terms and conditions of sale in place at the time of order acknowledgement.

Purchasers are solely responsible for the choice, selection, and use of ST products and ST assumes no liability for application assistance or the design of Purchasers’ products.

No license, express or implied, to any intellectual property right is granted by ST herein.

Resale of ST products with provisions different from the information set forth herein shall void any warranty granted by ST for such product.

ST and the ST logo are trademarks of ST. For additional information about ST trademarks, please refer to www.st.com/trademarks. All other product or service names are the property of their respective owners.

Information in this document supersedes and replaces information previously supplied in any prior versions of this document.

© 2019 STMicroelectronics – All rights reserved