

Transfer or duplication of this document as well as the utilisation or communication of its content are not permitted unless express consent is granted. Violations give rise to claims for damages. All rights reserved in case of patent, utility model or design patent registrations.

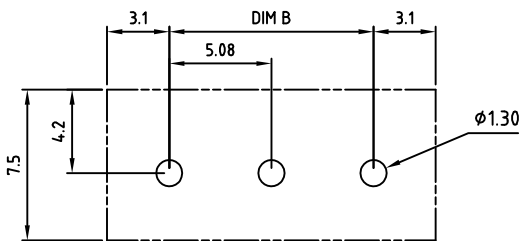
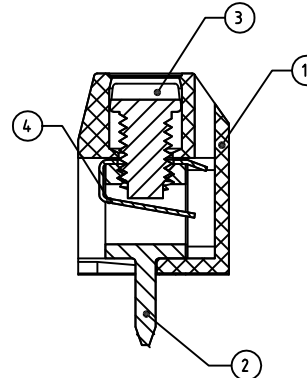
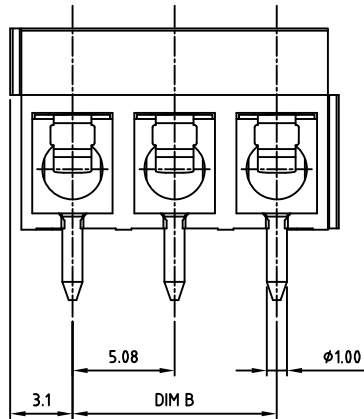
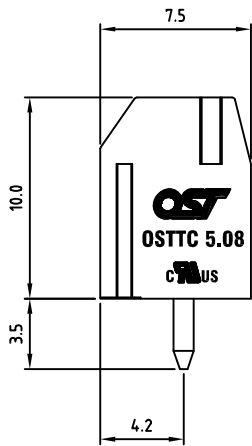
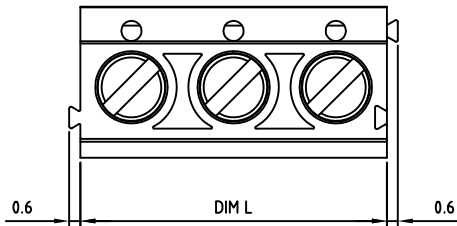

PCB LAYOUT

Technical data

1. Nominal voltage: 300V/15A
PITCH: 5.08mm
2. Connection capacity:
AWG 22-14
3. Insulation Withstanding Voltage:
AC 1600V/MIN
4. Insulation Resistance:
1000M Ω or more at DC500V
5. Tightening torque:
4.0kgf.cm (0.4N.m)
6. Screw thread: M2.6
7. Stripping length: 5-6mm
8. Operating temperature range: -40°C - 115°C
Soldering temperature: 250 \pm 10°C /5s
9. Undimensioned Tolerances:

Dim.L=Px5.08		
Dim.B=(P-1)x5.08		
P= number of poles(2-24P)		
	Dim B	Dim L
0-30mm	± 0.15	± 0.20
over 30mm-60mm	± 0.20	± 0.25
over 60mm-90mm	± 0.25	± 0.30
over 90mm	± 0.30	± 0.40

10. Safety approval:
11. RoHS Compliance

Part No.:

OSTTCXX2162

No. of Poles	COLOR
02 2 Poles	0: Black
03 3 Poles	2: Red
...	3: Orange
24 24 Poles	4: Yellow
	5: Green
	6: Blue (Standard)
	8: Grey

Nonstandard colors
Mins could apply

4	WIRE GUARD	Stainless steel		P
3	SCREW	STEEL	M2.6x0.4, Zn Plated	P
2	CAGE	BRASS	M2.6x0.4, Tin PLATED	P
1	BODY	PA66 UL94V-0	ALL COLOR	1
ITEM	NAME OF PART	MATERIAL	NOTES	Q'TY
DWG.	WF. Zhang	DATE	2015.11.23	UNITS: MM SHEET: 1 OF 1 Tolerance
CHK.		DATE		SCALE: NONE 2.5:1 (:) REV.: A X. ± 0.50
APP.		DATE		TITLE: OSTTC 5.08mm Series X.X ± 0.30
				2-Interlock "-" slot type X.XX ± 0.10
				PART NO. OSTTCXX2162 X* $\pm 1^{\circ}$
				DWG NO. OSTTCXX2162.dwg

	SIGN	DESCRIPTION	CHK.	DATE
--	------	-------------	------	------



ON-SHORE TECHNOLOGY, INC.