

XDPE12284C Digital Multi-phase Controller

8-phase Dual Loop Voltage Regulator

Features

- Compliant with Intel™ VR13 and VR13HC rev 1.3, IMVP8 rev 1.2 and IMVP9 rev 1.3 DC-DC converter specifications
- Compliant with Intel™ SVID rev 1.9.1 protocol
- Compliant with PMBus rev 1.3 compliant serial interface
 - Query voltage, current, temperature faults
 - Fault Response
 - Maximum supported bus speed 1 MHz
 - Support 1.8/3.3 V operation
- Output voltage regulation range: 0.2 V to 3.04 V
- Flexible phase assignment between the two loops: 8+0, 7+1, 6+2, ... ,4+4 phases
- Configurable autonomous phase add/drop
- Automatic phase detection at start-up
- Start-up into pre-bias voltage at the output
- Integrated power stage current sense
- Differential output voltage sense
- Digital current balancing
- Digitally programmable PID (Proportional, Integral, Differential) loop compensation
- Non-linear control for superior transient response
- Digitally programmable loadline
- Digital temperature compensation
- Input (+12 V) voltage and current sense
- Extensive fault detection and protection capabilities:
 - Input/output under voltage protection (IUVP/OUVP), Output over voltage protection (OOVP)
 - OCP instantaneous & averaged (total current)
 - Multiple OTP thresholds
 - Peak phase current pulse limiting
 - Negative current limit protection
 - Output voltage sense protection
- Internal non-volatile memory (NVM) to store multiple custom configurations
- RoHS compliant and Halogen free 40-lead QFN plastic package

Potential applications

- Core & memory power regulation for Intel™ VR13, VR13HC, IMVP8 and IMVP9 based Microprocessors
 - Servers
 - Workstations
 - High-end desktops

XDPE12284C Digital Multi-phase Controller

8-phase Dual Loop Voltage Regulator



Product validation

Product validation

Qualified for industrial applications according to the relevant tests of JEDEC47/20/22

Description

The XDPE12284 is a digital dual rail 8 phase controller that provides power for Intel™ VR13, VR13HC, IMVP8 and IMVP9 server, workstation, and high-end desktop applications. The controller offers flexible phase assignment between the two loops and can be configured in any of the following ways: 8+0, 7+1, 6+2, ... ,4+4. Command and monitor functions are controlled through the SVID interface which supports dynamic voltage identification (DVID) with 5 mV/step or 10 mV/step, power states (PS), VR Data and Operating Registers requirements.

The XDPE12284 controller utilizes digital technology to implement all control functions, providing the ultimate system solution in terms of flexibility and stability. Advanced control loop features, such as Active Transient Response (ATR) modulation and fast DVID response enable optimal response to high slew rate load transients.

Programmable temperature compensation to current sense allows the designer to tailor the response for best loadline accuracy over temperature. XDPE12284 also supports integrated power stages that provides integrated current sense and integrated temperature sense information.

Protection features include a set of sophisticated over-voltage, under-voltage, over-temperature, and over-current protections. These attributes provide a complete and advanced protection feature set for microprocessor and power systems.

Infineon strongly recommends pairing Infineon's powerstages with our Digital XDP™ family of controllers to ensure correct interoperability. Interoperability when pairing with other vendor power stages/ discrete power components cannot be guaranteed by Infineon and requires thorough evaluation and characterization by the power stage/ discrete power component vendor.

Table 1 Part number and package summary

Part Number	Package
XDPE12284	40-lead 5 mm x 5 mm QFN PG-VQFN-40

XDPE12284C Digital Multi-phase Controller

8-phase Dual Loop Voltage Regulator



Typical application diagram

Ordering information

Table 2 Ordering information

Base Part Number	Package Type	Standard Pack		Orderable Part Number
		Form and Quantity		
XDPE12284C-xyxy	QFN 5 mm x 5 mm	Tape and Reel	4000	Note 1

Note:

1. Customer Specific Configuration File, where xx = Customer ID and yy = Configuration File (Codes assigned by IFX Marketing). Default part with generic customer configuration file will be marked as "0000".

Prototype Samples

The customer can program the parts to their specific system requirements using software/hardware available from Infineon or through other controller programming facilities (contact Infineon for recommendations). Infineon Field Application Engineers are available to assist with system and configuration file optimization and programming of the controllers. Alternatively, samples can also be ordered with a customer specific custom configuration pre-programmed at the factory. The generic part numbering format is shown below:

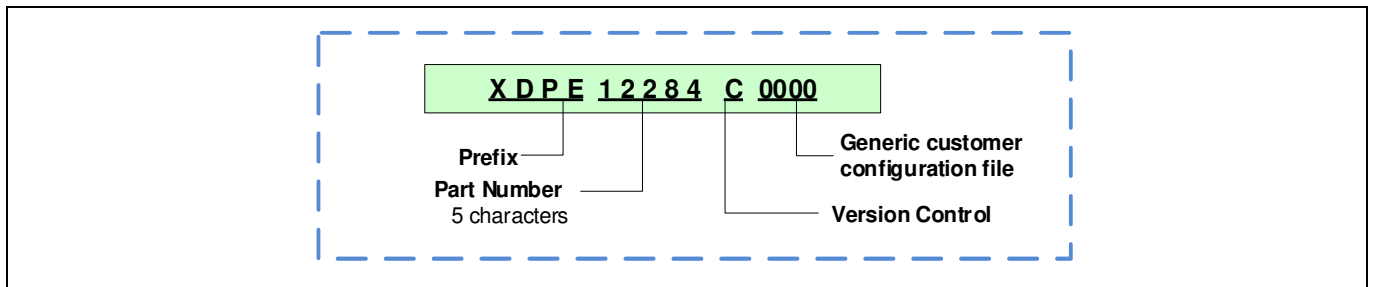

Figure 1 Part number decoding

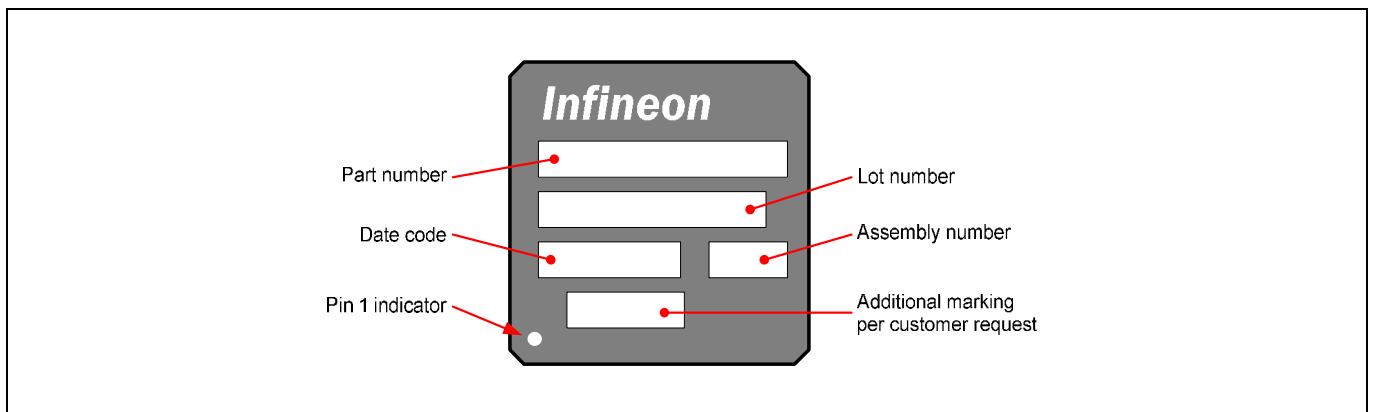

Figure 2 Generic example of package marking

1 Typical application diagram

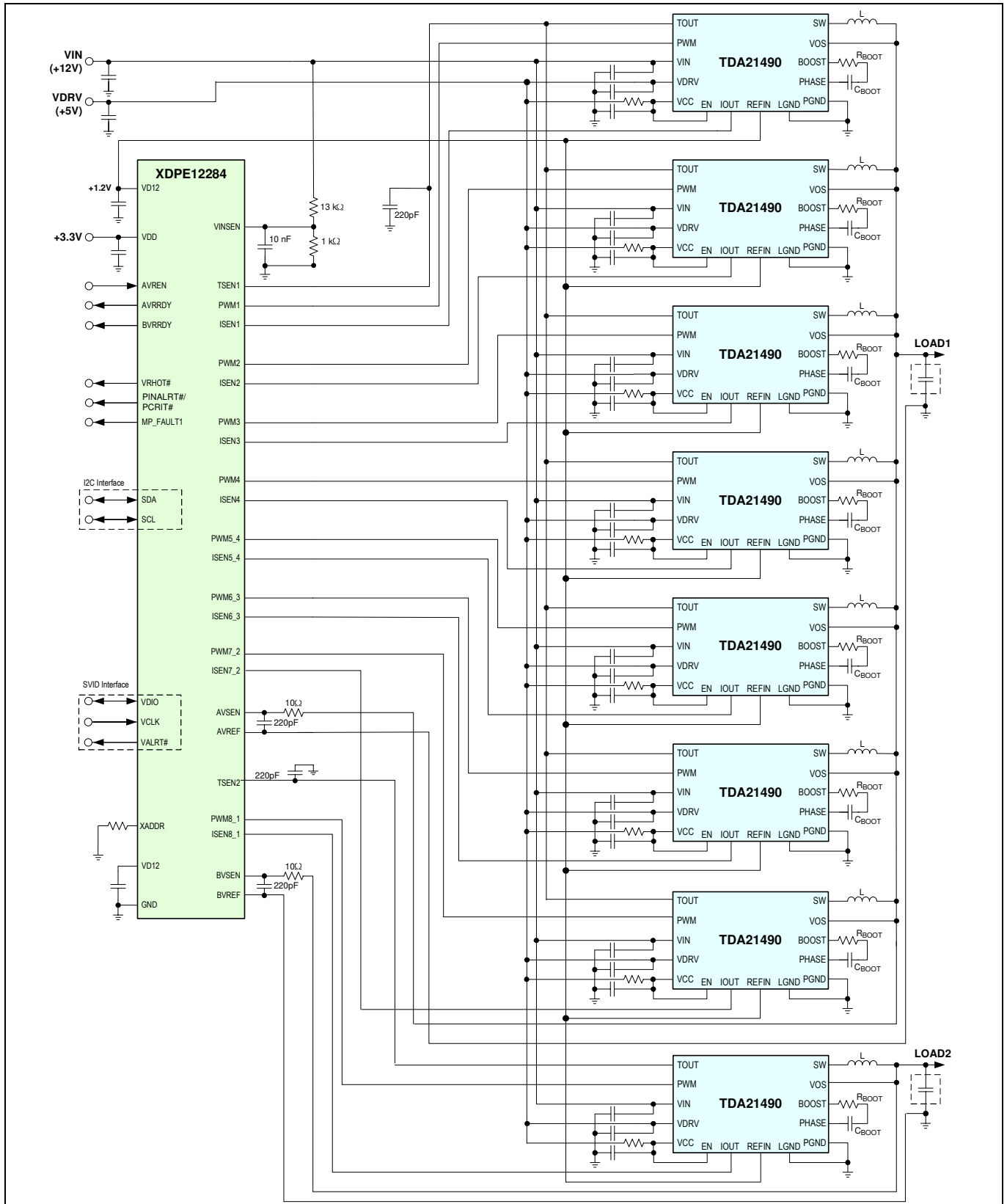

Figure 3 Dual Loop VR using XDPE12284 Controller and TDA21490 Power Stage in 7+1 Phase Configuration

Trademarks

All referenced product or service names and trademarks are the property of their respective owners.

Edition 2021-07-15

Published by

Infineon Technologies AG

81726 Munich, Germany

© 2022 Infineon Technologies AG.

All Rights Reserved.

Do you have a question about this document?

Email: erratum@infineon.com

Document reference

XDPE12284C

IMPORTANT NOTICE

The information given in this document shall in no event be regarded as a guarantee of conditions or characteristics ("Beschaffheitsgarantie").

With respect to any examples, hints or any typical values stated herein and/or any information regarding the application of the product, Infineon Technologies hereby disclaims any and all warranties and liabilities of any kind, including without limitation warranties of non-infringement of intellectual property rights of any third party.

In addition, any information given in this document is subject to customer's compliance with its obligations stated in this document and any applicable legal requirements, norms and standards concerning customer's products and any use of the product of Infineon Technologies in customer's applications.

The data contained in this document is exclusively intended for technically trained staff. It is the responsibility of customer's technical departments to evaluate the suitability of the product for the intended application and the completeness of the product information given in this document with respect to such application.

For further information on the product, technology delivery terms and conditions and prices please contact your nearest Infineon Technologies office (www.infineon.com).

WARNINGS

Due to technical requirements products may contain dangerous substances. For information on the type in question please contact your nearest Infineon Technologies office.

Except as otherwise explicitly approved by Infineon Technologies in a written document signed by authorized representatives of Infineon Technologies, Infineon Technologies' products may not be used in any applications where a failure of the product or any consequences of the use thereof are reasonably be expected to result in personal injury.