

Customer Information Sheet

DRAWING No.: M22-533XX05

IF IN DOUBT - ASK

©

NOT TO SCALE

THIRD ANGLE PROJECTION

ALL DIMENSIONS IN mm

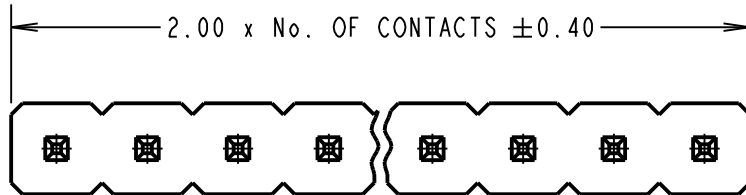

ORDER CODE:

M22-533XX05

No. OF CONTACTS:
02 TO 15

Active products:

M22-5330205
M22-5330305
M22-5330405
M22-5330505
M22-5330605
M22-5331405

SPECIFICATION:

MATERIAL:

MOULDING = PA9T UL94V-0, BLACK

CONTACT = BRASS

FINISH:

CONTACT = GOLD FLASH OVER NICKEL

ELECTRICAL:

CURRENT RATING = 2A

CONTACT RESISTANCE = $20m\Omega$ MAX

INSULATION RESISTANCE = $1000M\Omega$ MIN

DIELECTRIC STRENGTH = 500V AC/DC MINUTE

ENVIRONMENTAL:

TEMPERATURE RANGE = $-40^{\circ}C$ TO $+105^{\circ}C$

PACKING: BOX

FOR COMPLETE SPECIFICATION, SEE COMPONENT SPECIFICATION CO18XX (LATEST ISSUE)

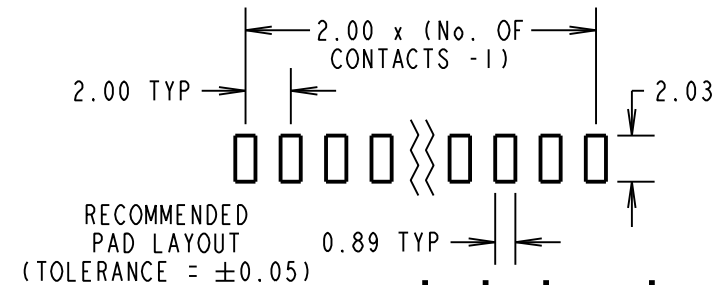
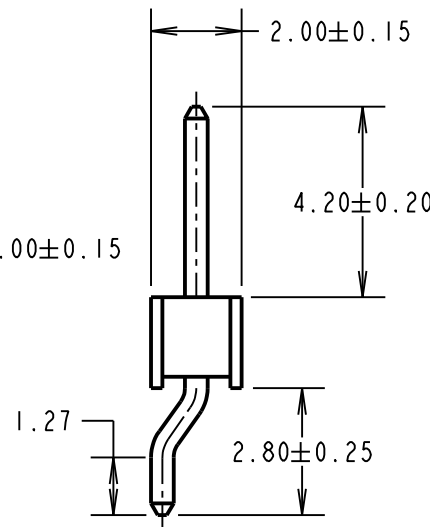
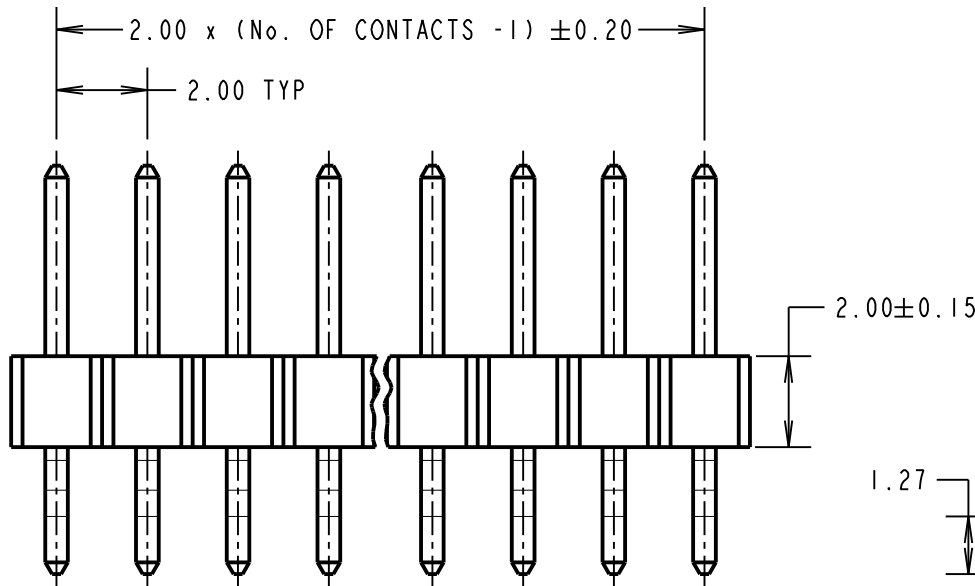

OBSOLETE
All other size/finish combinations not listed above

SB	6	26.05.16	13367
NAME	ISS.	DATE	C/NOTE
APPROVED:		S.BENNETT	
CHECKED:		M.PERREN	
DRAWN:		J.EVANS	
CUSTOMER REF.:			
ASSEMBLY DRG:			

HARWIN

www.harwin.com
technical@harwin.com

THIS DRAWING AND ANY INFORMATION OR DESCRIPTIVE MATTER SET OUT HEREON ARE CONFIDENTIAL AND COPYRIGHT PROPERTY OF THE HARWIN GROUP AND MUST NOT BE DISCLOSED, LOANED, COPIED OR USED FOR MANUFACTURING, TENDERING OR FOR ANY OTHER PURPOSE WITHOUT THEIR WRITTEN PERMISSION.

TOLERANCES

X. = $\pm 1mm$
X.X = $\pm 0.50mm$
X.XX = $\pm 0.10mm$
X.XXX = $\pm 0.01mm$

ANGLES = $\pm 5^{\circ}$
UNLESS STATED

MATERIAL:

SEE ABOVE

FINISH:

SEE ABOVE

S/AREA:

mm²

TITLE:

2.00mm PITCH SIL HORIZONTAL SMT PIN HEADER ASSEMBLY

DRAWING NUMBER:

M22-533XX05

SHT

2 OF 2