

REFERENCE SPECIFICATIONS

-NFC 93425 (in compliance with HE 507)

PHYSICAL CHARACTERISTICS

-INSULATOR MATERIAL: THERMOPLASTIC UL94V0

-CONTACT MATERIAL: PHOSPHOR BRONZE

-ACCESSORIES: BRASS

-SHELLS: STEEL

ELECTRICAL CHARACTERISTICS

-NOMINAL CURRENT: 7.5A

-CONTACT RESISTANCE: <= 7.3 m ohms

-CONTACT/CONTACT : >=1000 V

-CONTACT/GROUND : >=1200 V

-INSULATION RESISTANCE: >=5000 MOhms

ENVIRONMENTAL CHARACTERISTICS

- CLIMATIC CATEGORY: 55/125/21

TEMPERATURE RANGE -55°C TO +125°C

DAMP HEAT STEADY STATE 21 DAYS

SALT SPRAY 24 HOURS

MECHANICAL CHARACTERISTICS

- RETENTION AGAINST TORQUE: - Threaded insert: 0.7 N.m Maximum

- Female screw : 0.5 N.m Maximum

NOTE RoHS INFORMATION

- The "LF" products meet european union Directives and other country regulations as described in GS-47-0004.

- Termination plating spec:

Ni + Gold/GxT

- Active area plating spec:

Ni + Gold/GxT

- Shell plating :2 to 4µm Cu + Nickel + 3 to 10µmm Sn,pure bright

- Accessories: Sn pure bright + nickel

- Packaging spec: See GS-14-920

DBL13W3S043A00LF

Series ←

Shell size: **E A B C D** ←
see sheet 2

Front accessory definition ←
see sheet 2

- Blank** :without accessory
- L** :threaded insert M3
- O** :threaded insert UNC 4-40

Layout of contacts (see sheet 3) ←

Contacts ←

- S** :Socket

Plating ←

- Blank** signal solder bucket 200 matings/unmatings
- 043** signal solder bucket 500 matings/unmatings

PCB accessory definition ←

- A** without accessory on PCB

Power contacts ←

- 00** without power contact

See note RoHS

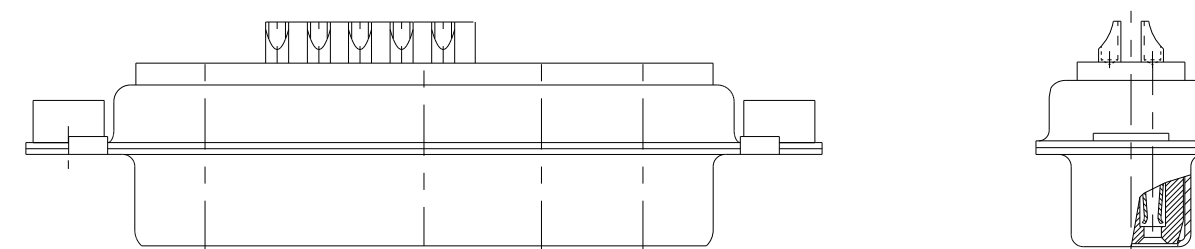

13W3 FOR EXAMPLE

spec ref	dr	1, Product Eng	2015/06/12	projection	MM	size	A2	scale	1:1
tolerance std	eng	Gregar Mathew	2019/11/11			ecn no	ELX-433002-1	rel level	Released
ISO 406 ISO 1100 ISO 1101 ISO 408	chr	-	appr						
surface	linear	0.X ±0.30.30 0.XX ±0.1 0.XXX ±0.05			title SUB FEMALE DW MIXED POWER + SOLDER BUCKET		cat. no.	Product - Customer Drw	sheet 1 of 7
ISO 1302	angular	0° ±22°	Amphenol FCI	title	SUB FEMALE DW MIXED POWER + SOLDER BUCKET	cat. no.	C01-8639-2303	rev	E

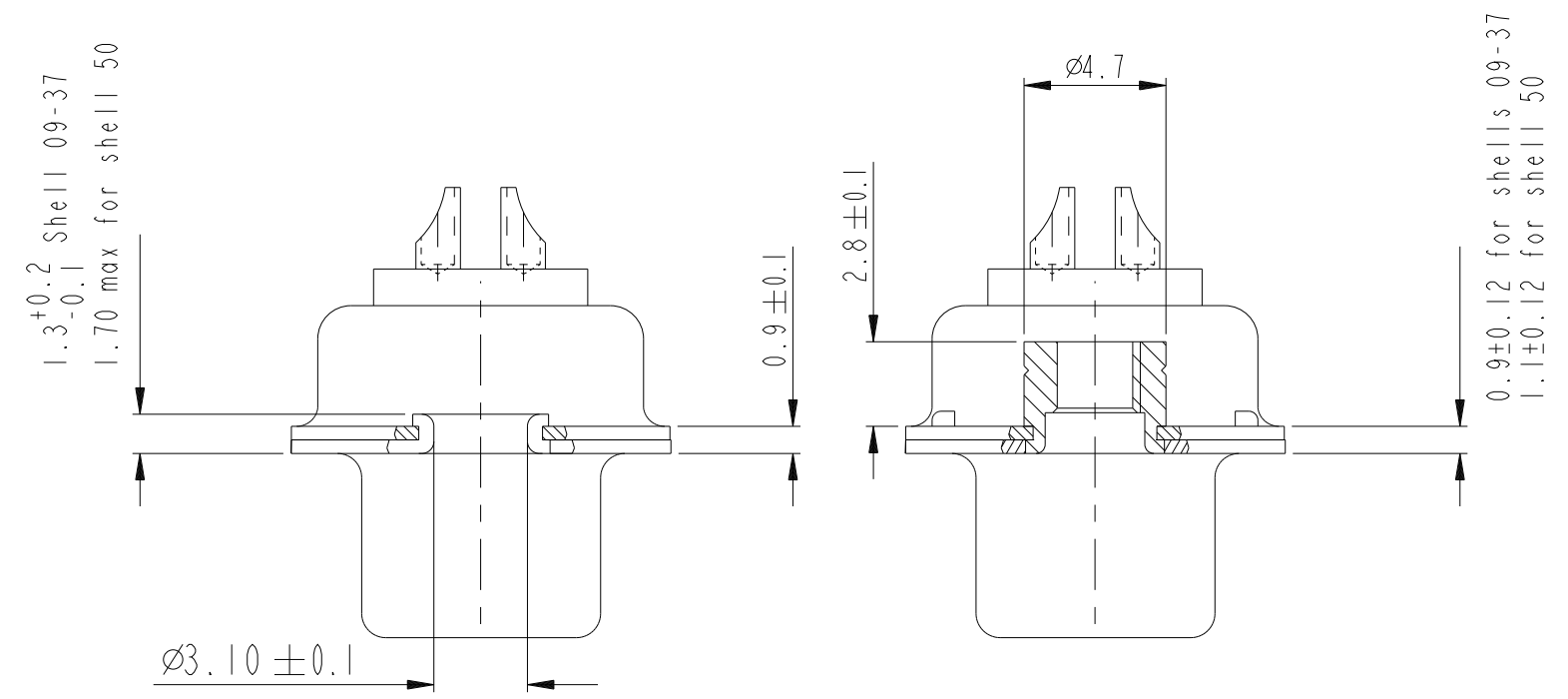

FRONT ACCESSORY	Blank without	L insert M3
		O insert UNC 4.40
PCB ACCESSORIES	A without	A without

PART NUMBER	MATINGS/ UNMATINGS	FRONT ACCESSORY	PCB ACCESSORIES
D*xWxSA00LF	200	without	without
D*LxWxSA00LF	200	insert M3	without
D*OxWxSA00LF	200	insert UNC 4.40	without
D*xWxS043A00LF	500	without	without
D*LxWxS043A00LF	500	insert M3	without
D*OxWxS043A00LF	500	insert UNC 4.40	without

shell size	LAYOUTS
*	xWx
E	5W1
A	11W1
A	7W2
B	21W1
B	17W2
B	13W3
B	9W4
C	25W3
C	21WA4
C	27W2
D	47W1
D	24W7
D	36W4

Amphenol
FCi

© 2016 AFci

spec ref	dr	1, Product Eng	2015/06/12	projection	MM	size	A2	scale	1:1
tolerance std	eng	Gregar Mathew	2019/11/11			ecn no	ELX-33002-1	rel level	Released
ISO 1101 ISO 406	chr	-	appr						
surface	linear	0.X	±0.30			Amphenol FCI		title	SUB FEMALE DW
ISO 1302		0.XX	±0.30			Amphenol FCI		diag no	C01-8639-2303
		0.XXX	±0.05			Amphenol FCI		rev	E
	angular	0°	±2°			Amphenol FCI		cat. no.	-
				Product - Customer Drw		sheet 2 of 7			

PDS: Rev :E

STATUS:Released

Printed: Nov 12, 2019

5W1

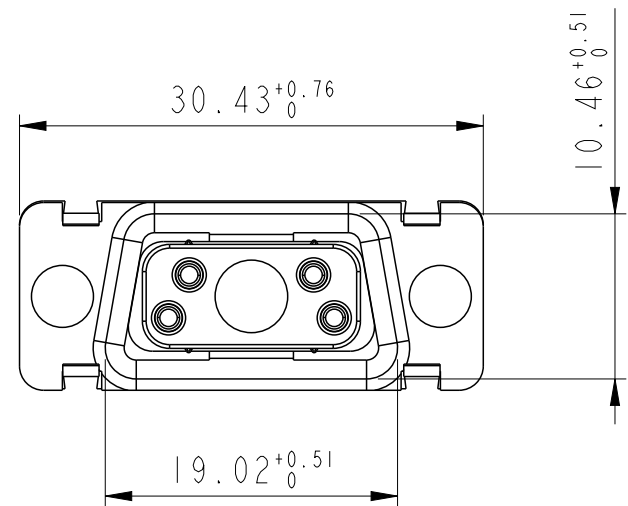
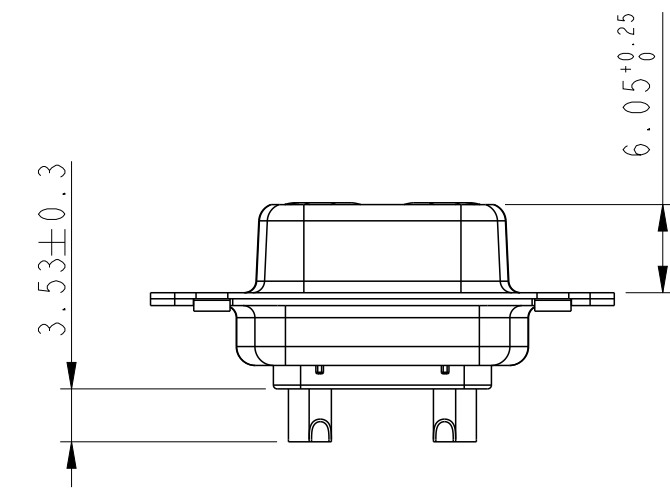
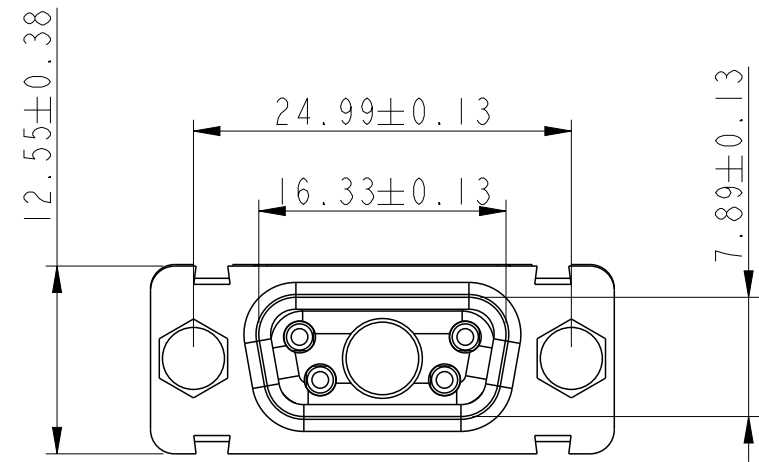

Floating signal contacts

11W1

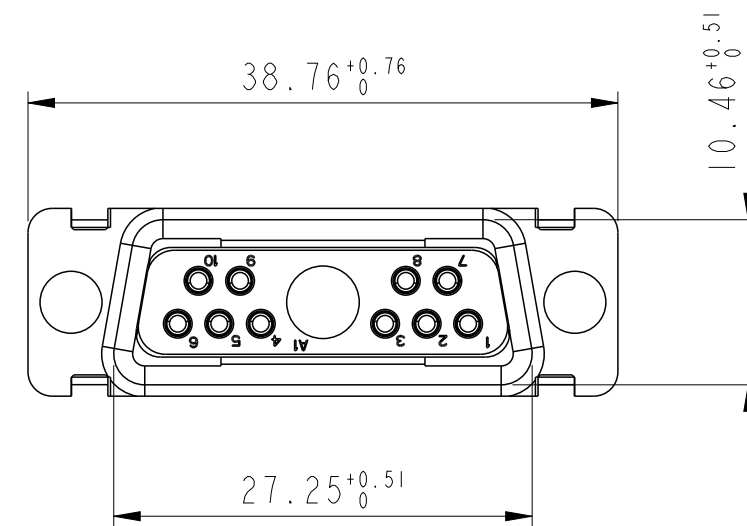
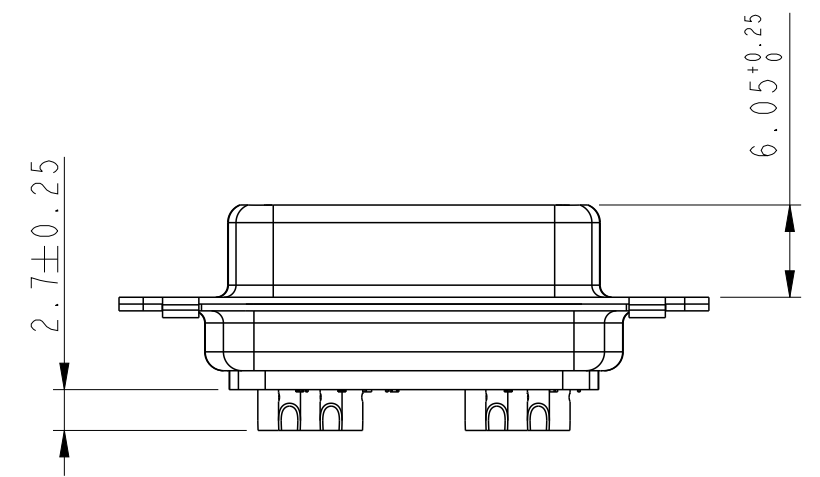
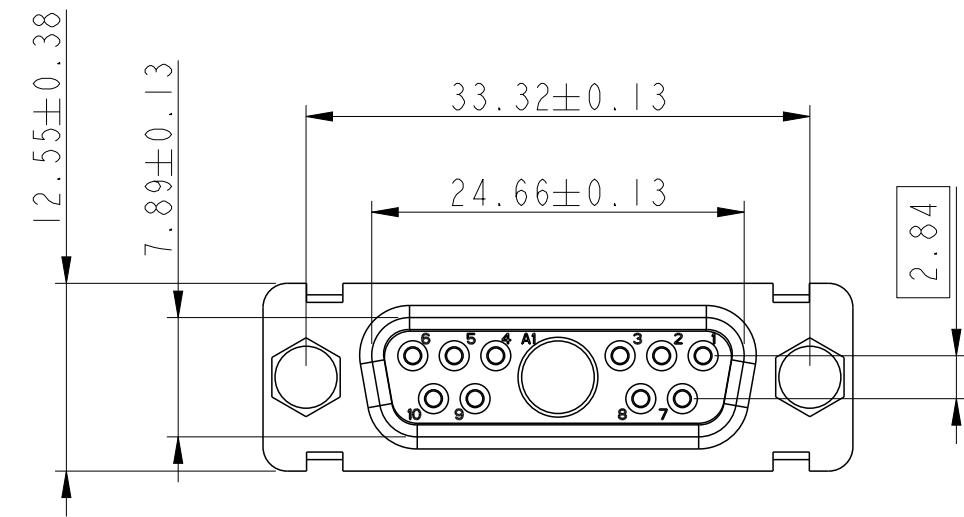

7W2

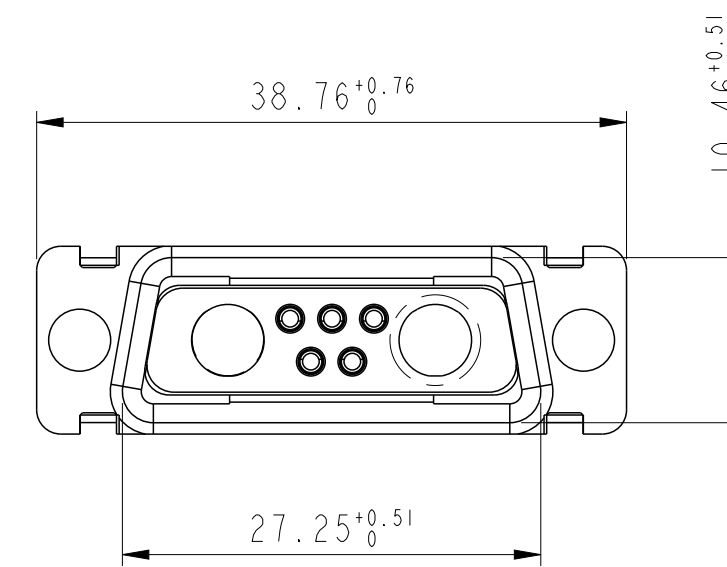
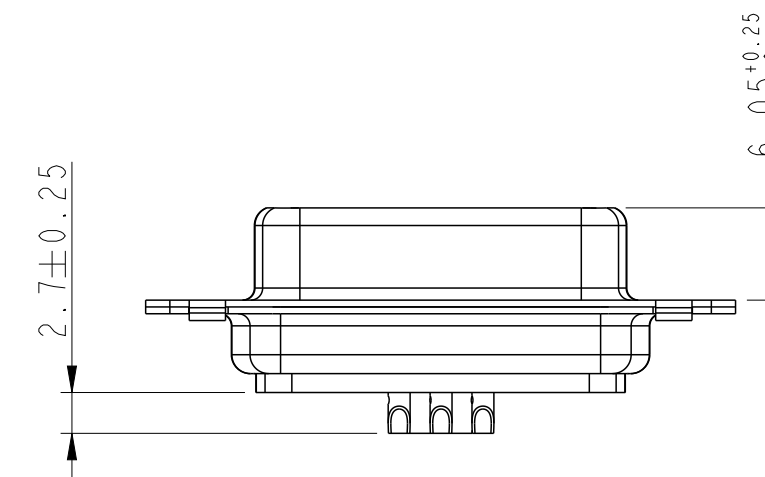
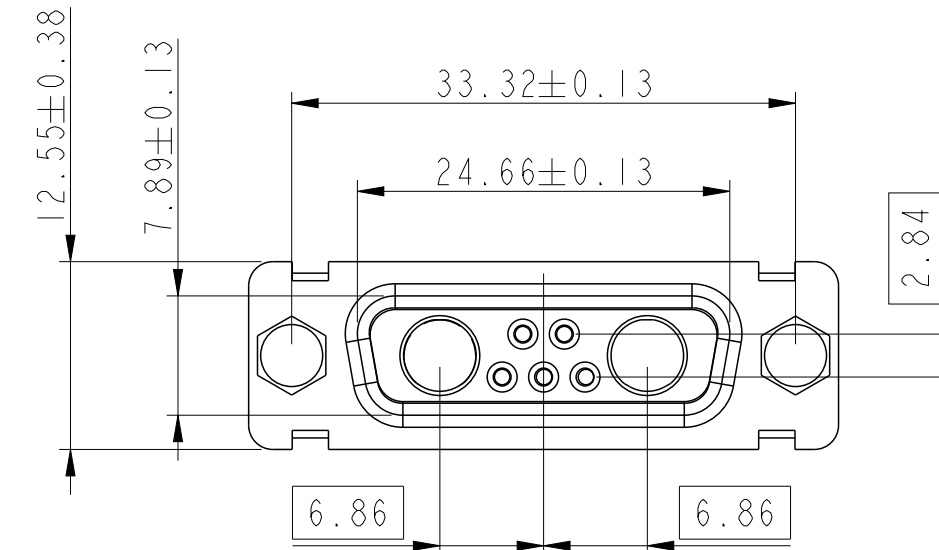

SIDE VIEW FOR LAYOUTS: E A B C

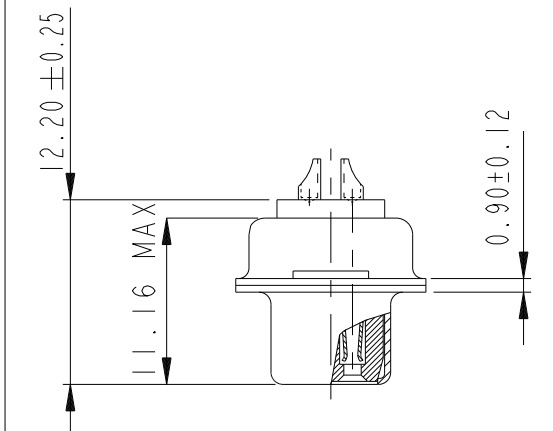

spec ref	dr	1, Product Eng	2015/06/12	projection	MM	size	A2	scale	2:1	
tolerance std	eng	Gregar Mathew	2019/11/11			ecn no	ELX-33002-1	rel level	Released	
ISO 1101 ISO 406	chr	-	app							Varma Sudhir
surface	linear	0.X	±0.30	Amphenol FCI				title SUB FEMALE DW MIXED POWER + SOLDER BUCKET	dwg no C01-8639-2303	rev E
ISO 1302	angular	0°	±2°							

13W3

9W4

17W2

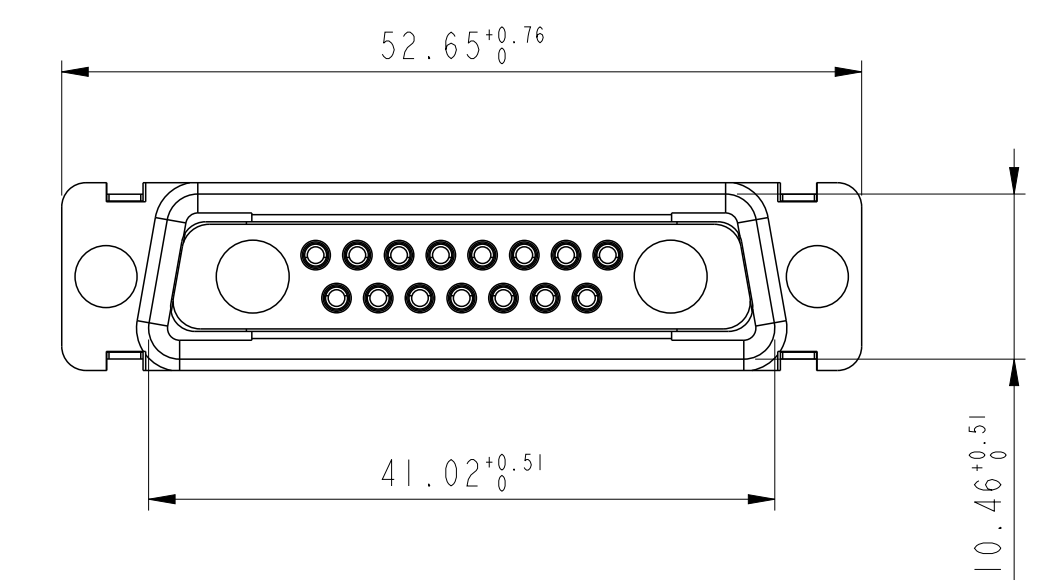
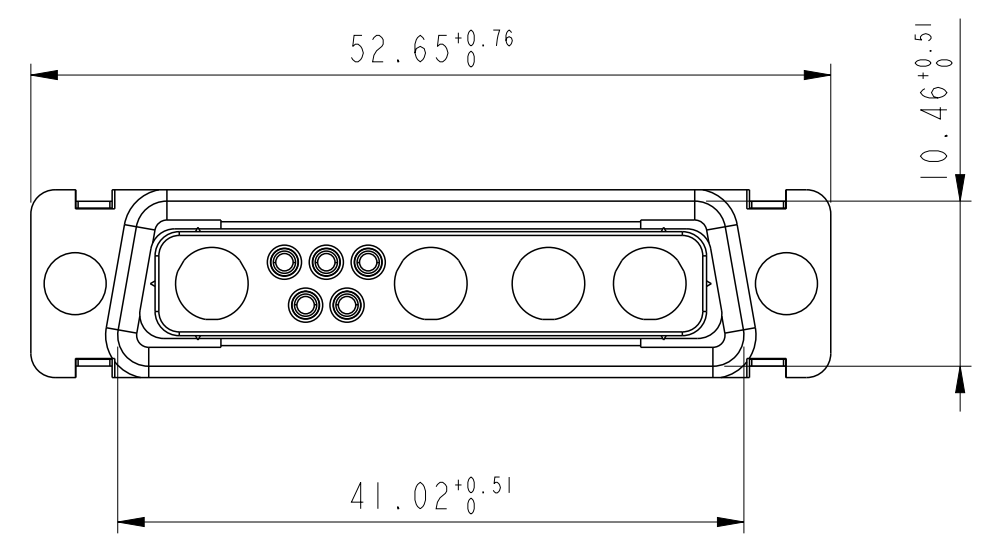
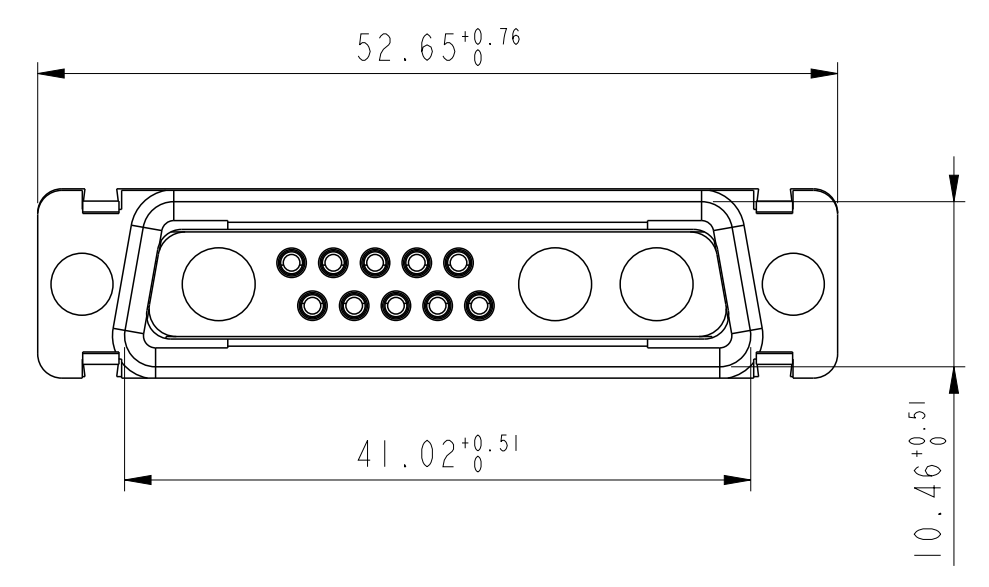
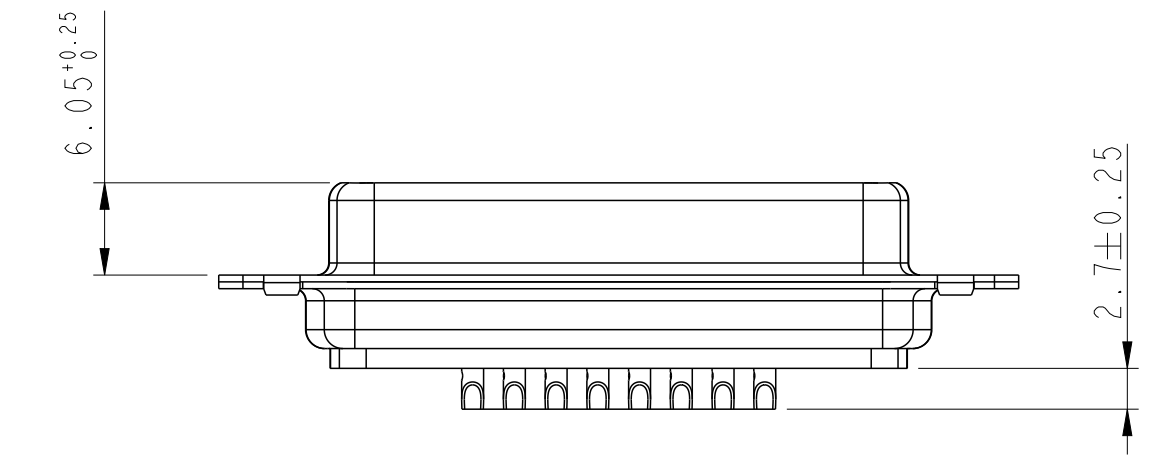
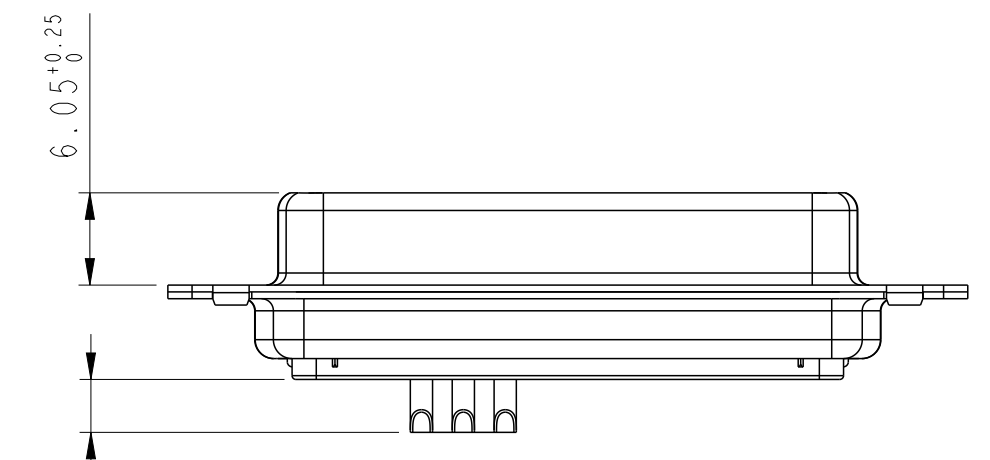
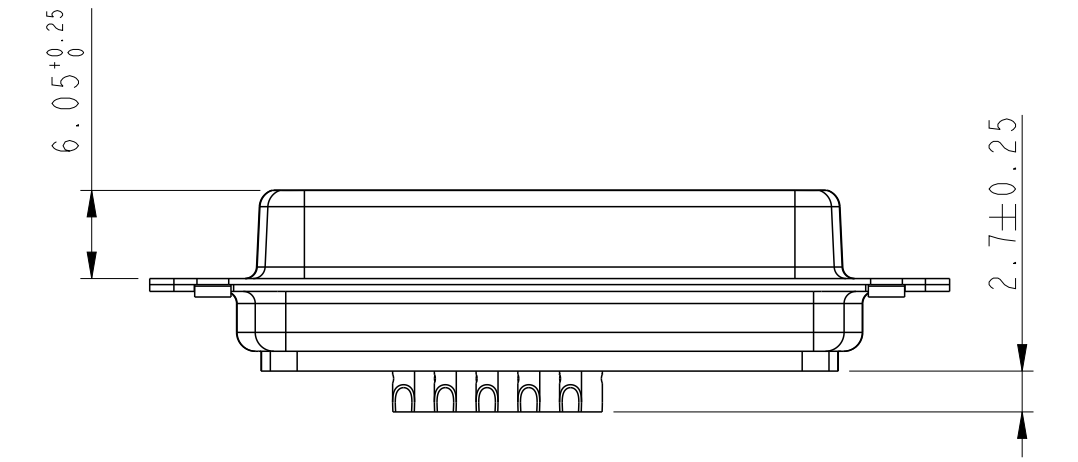
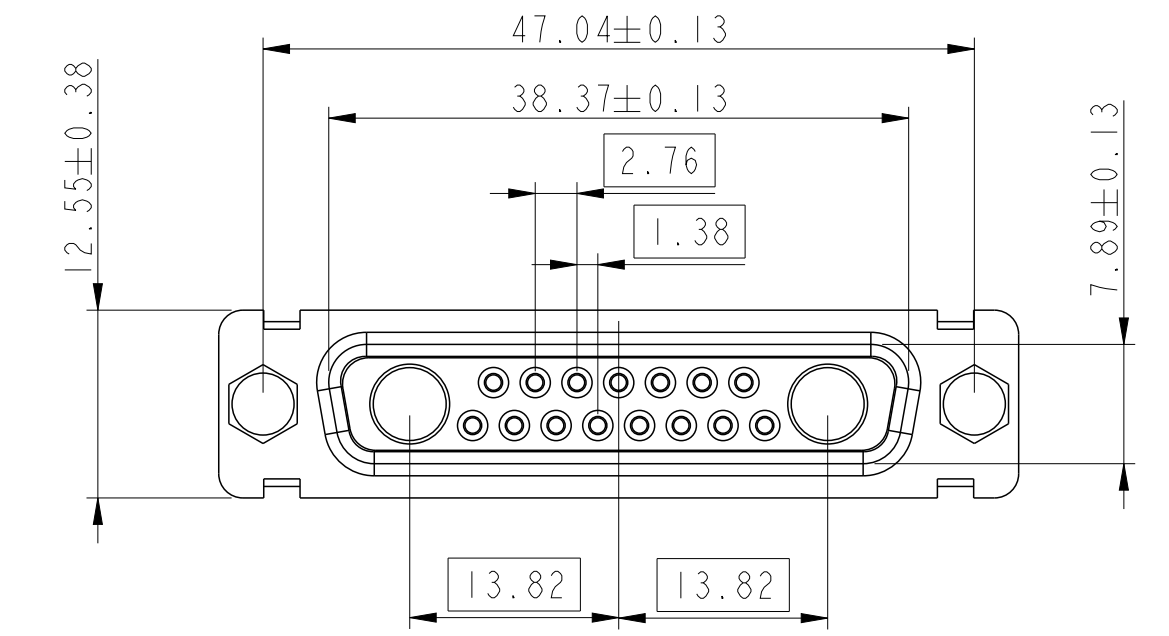
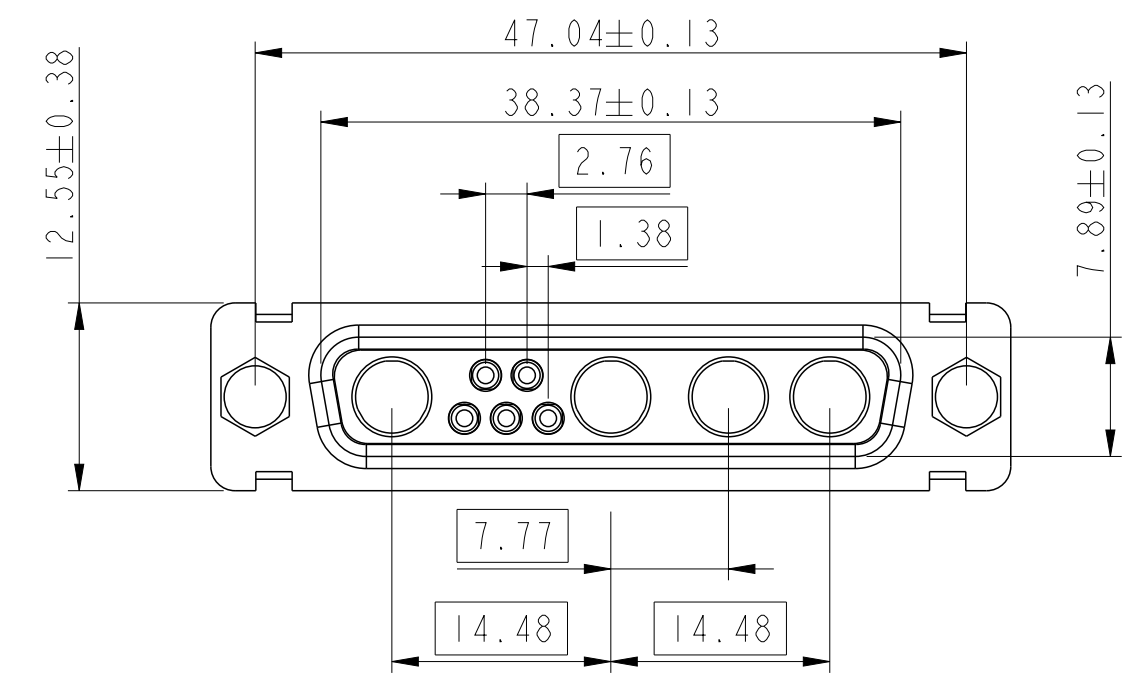
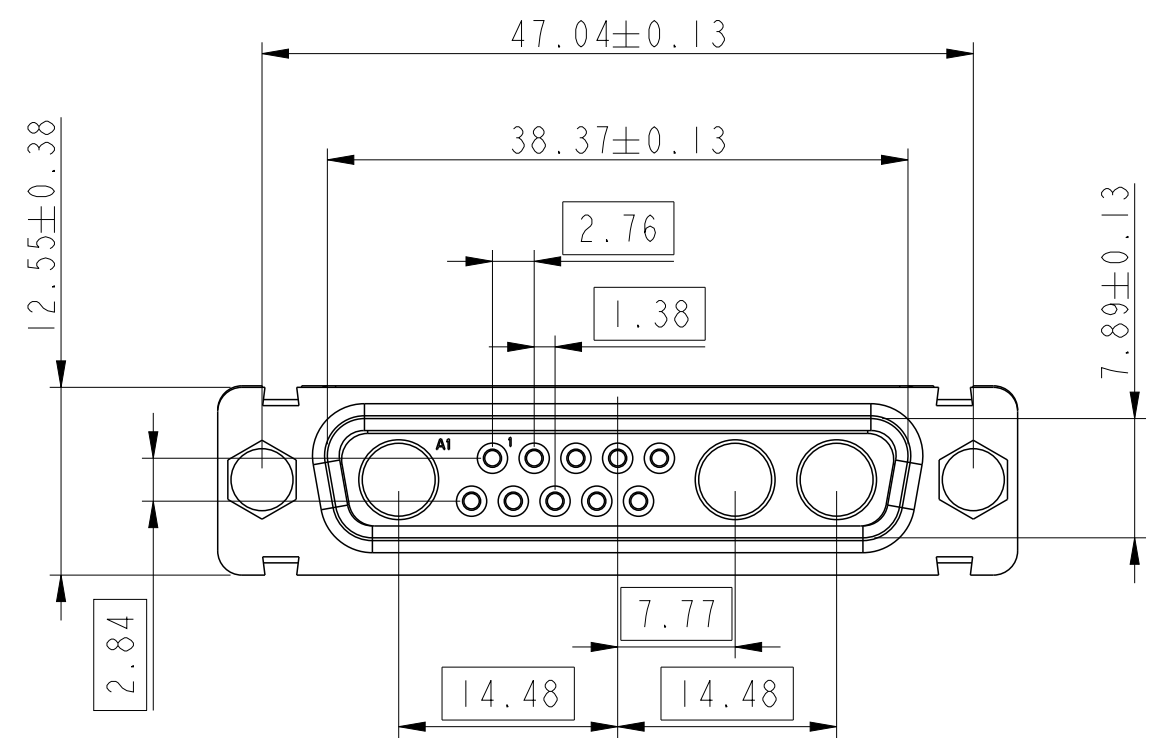

Floating signal contacts

Amphenol FCI

© 2016 AFCI

spec ref	dr	1, Product Eng	2015/06/12	projection	MM	size	A2	scale	2:1		
tolerance std	eng	Gregar Mathew	2019/11/11			ecn no	ELX-33002-1				
ISO 1101	chr	-	-								
ISO 406	appr	Varma Sudhir	2019/11/12	product family	D SUB	rel level	Released				
surface	linear			Amphenol FCI		title	SUB FEMALE DW		dwg no C01-8639-2303	rev	E
ISO 1302	angular	0°	±2°	MIXED POWER + SOLDER BUCKET		cat. no.	-			Product - Customer Drw	sheet 4 of 7

PDS: Rev :E

STATUS:Released

Printed: Nov 12, 2019

21W1

27W2

21WA4

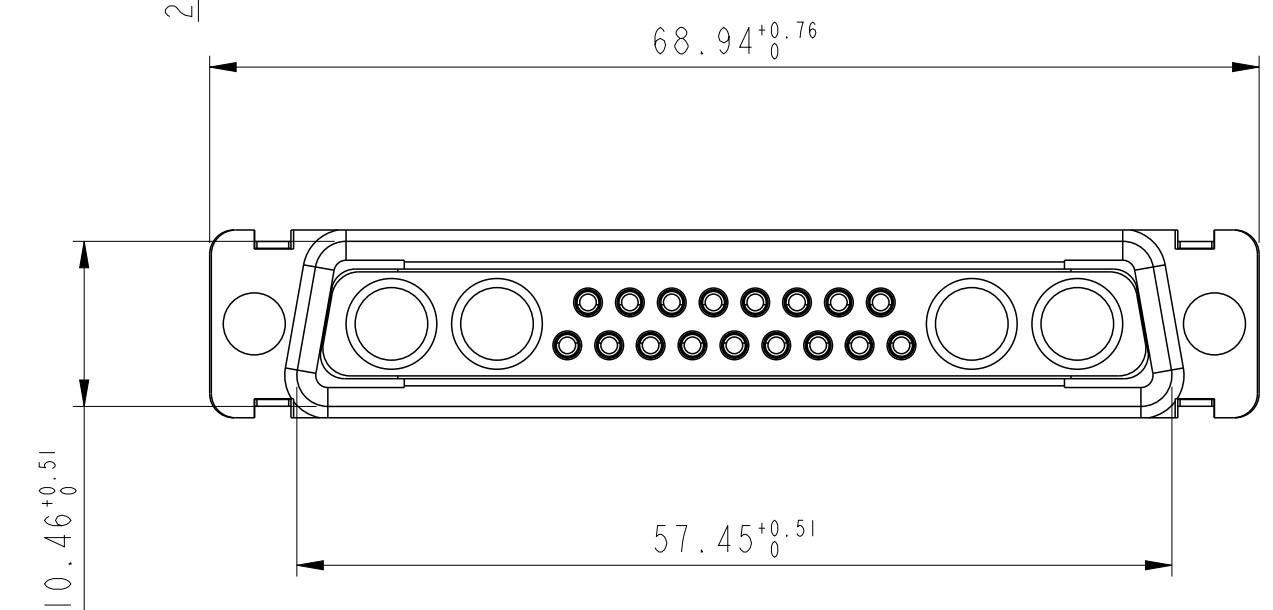
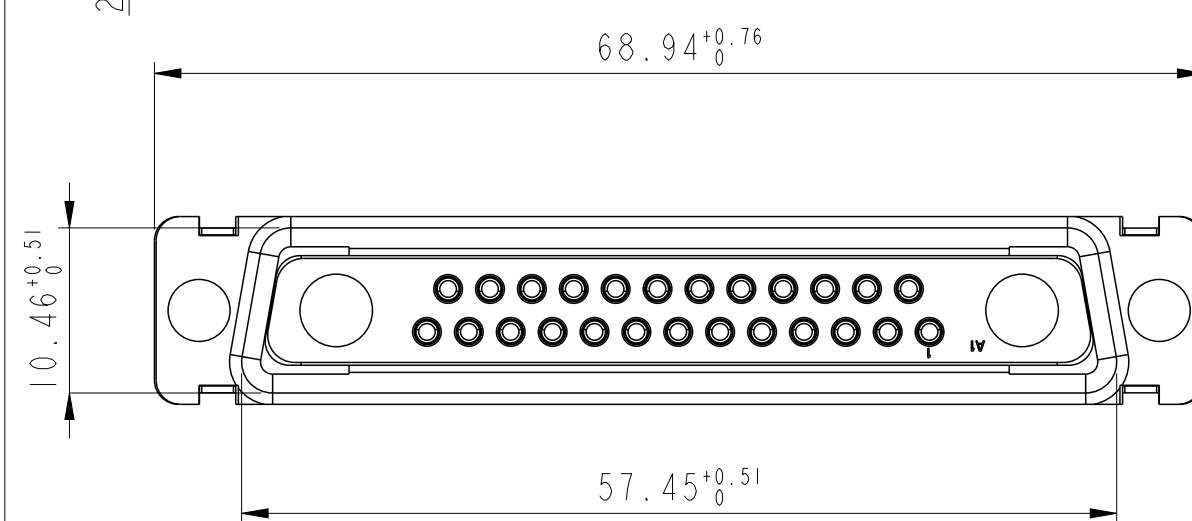
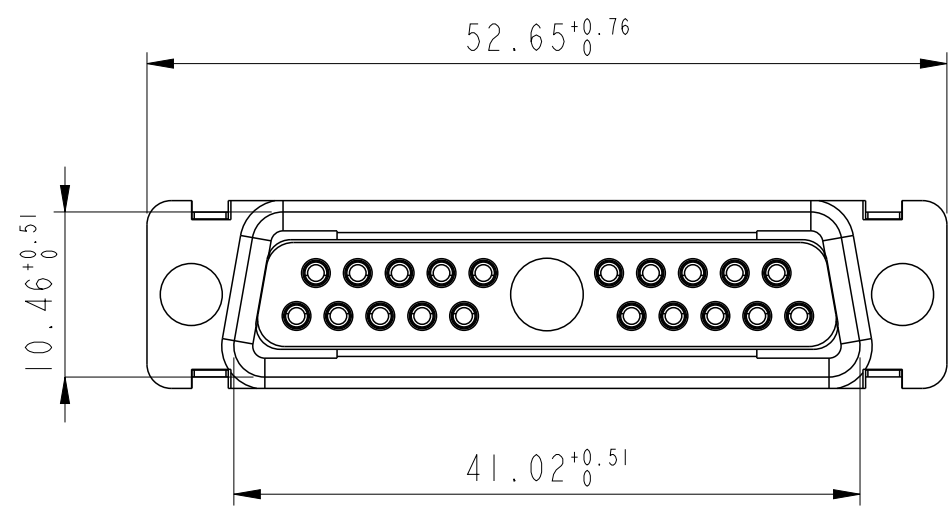
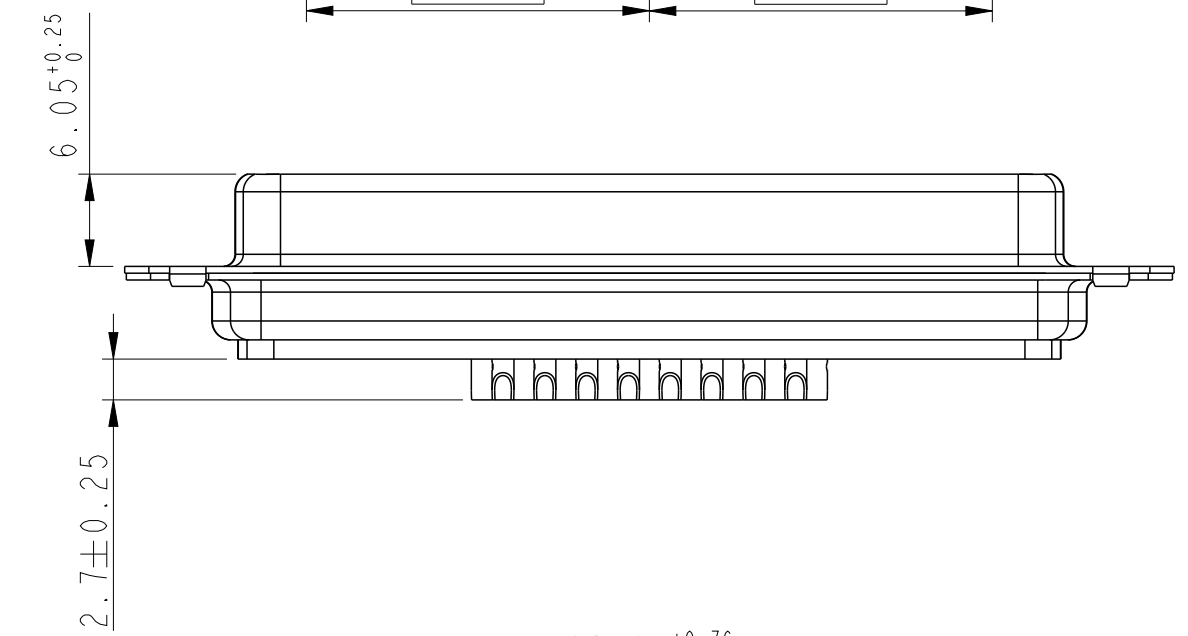
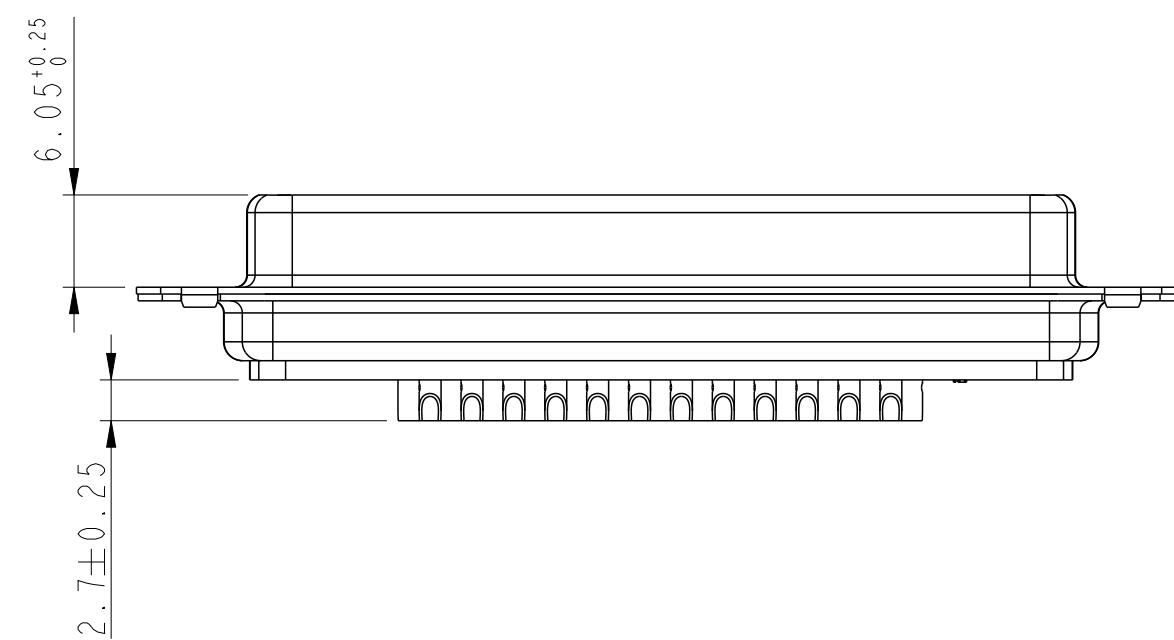
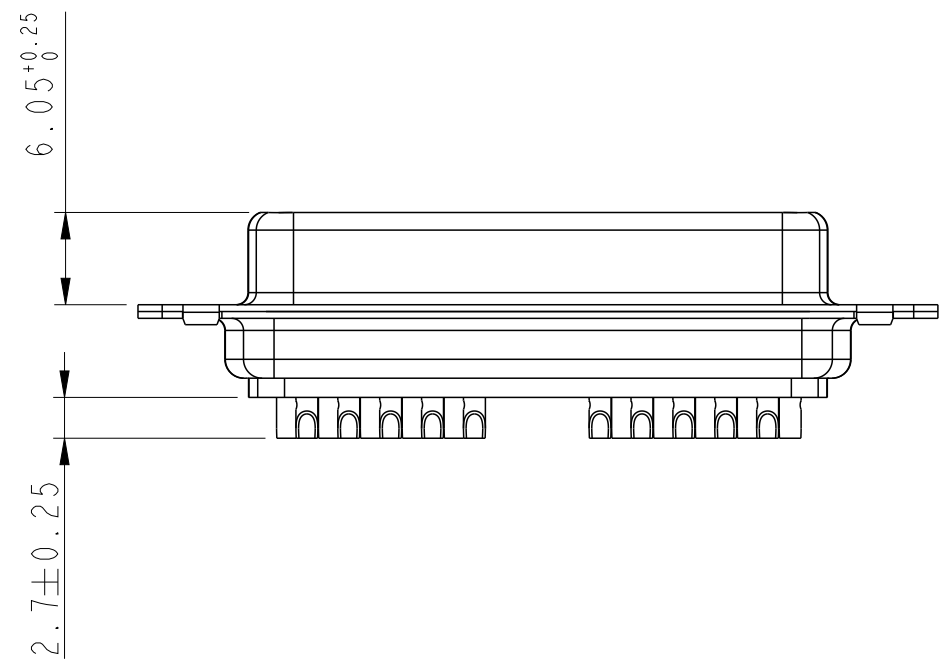
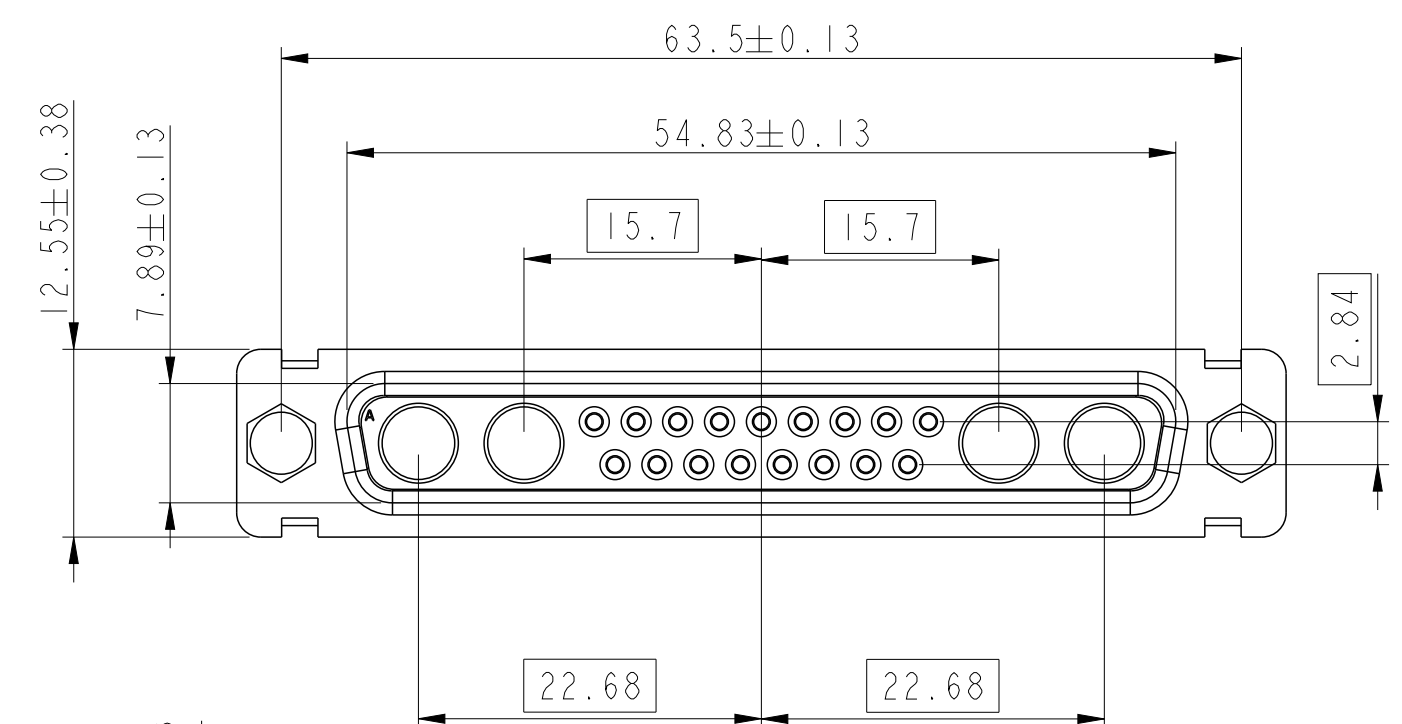
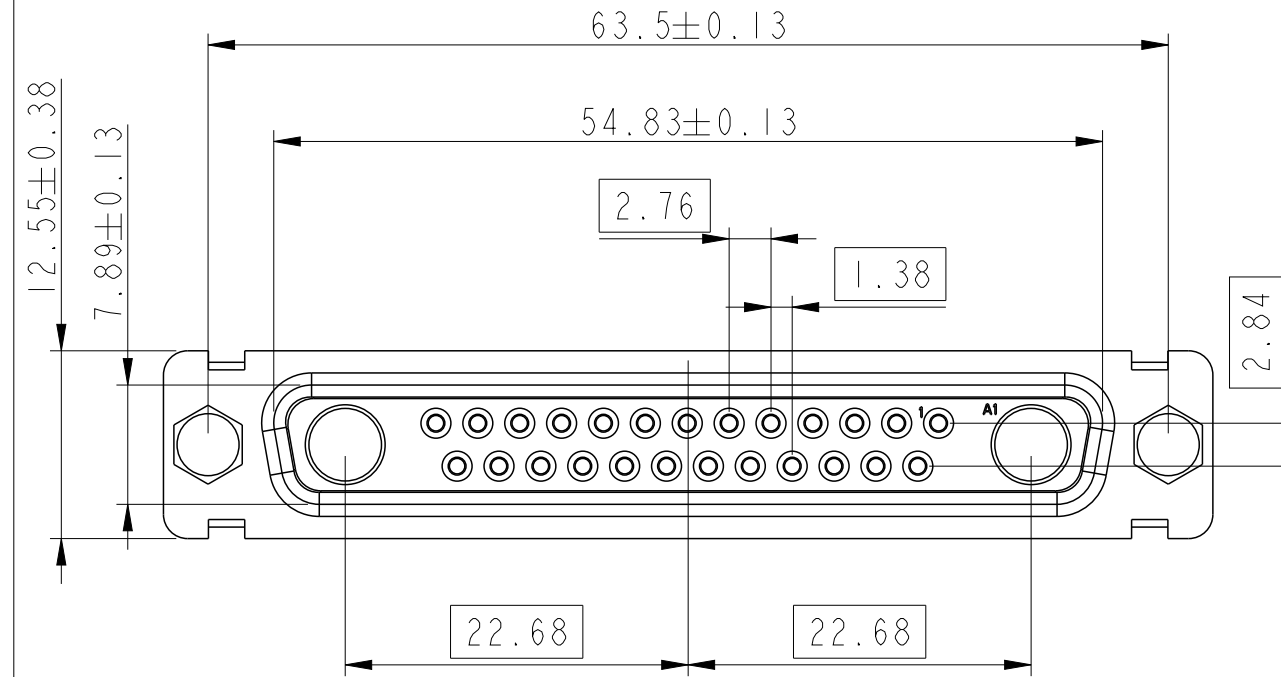
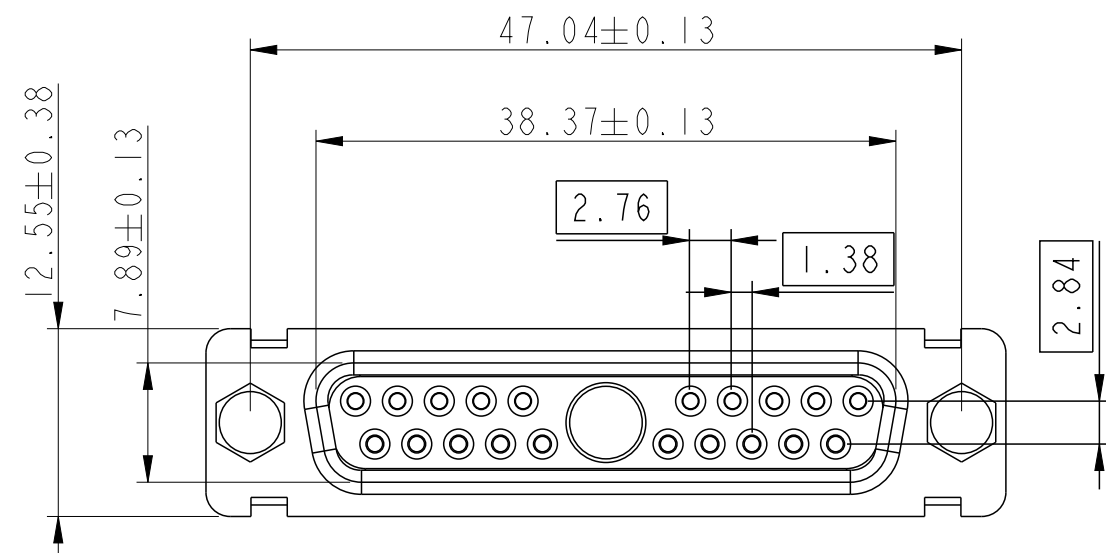

Amphenol FCI

© 2016 APCI

spec ref	dr	1, Product Eng	2015/06/12	projection	MM	size	A2	scale	2:1
tolerance std	eng	Gregar Mathew	2019/11/11			ecn no	ELX-33002-1	rel level	Released
ISO 1101 ISO 406	chr	-	2019/11/12						
TOLERANCES UNLESS OTHERWISE SPECIFIED		appr	Varma Sudhir	SUB FEMALE DW		dwg no	C01-8639-2303		rev
surface	linear	Amphenol FCI		MIXED POWER + SOLDER BUCKET		Product - Customer Drw		sheet 5 of 7	E
ISO 1302	angular	cat. no.		-		-		-	

PDS: Rev :E

STATUS:Released

Printed: Nov 12, 2019

25W3

24W7

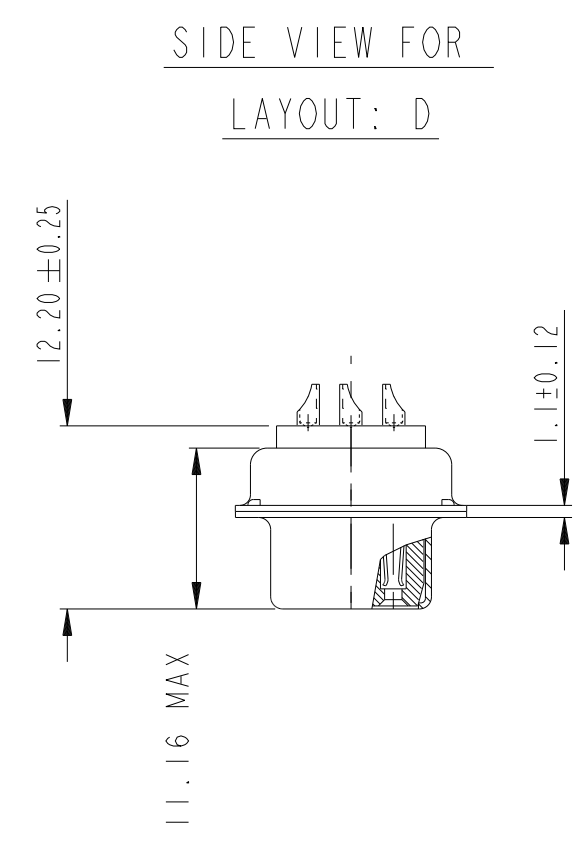
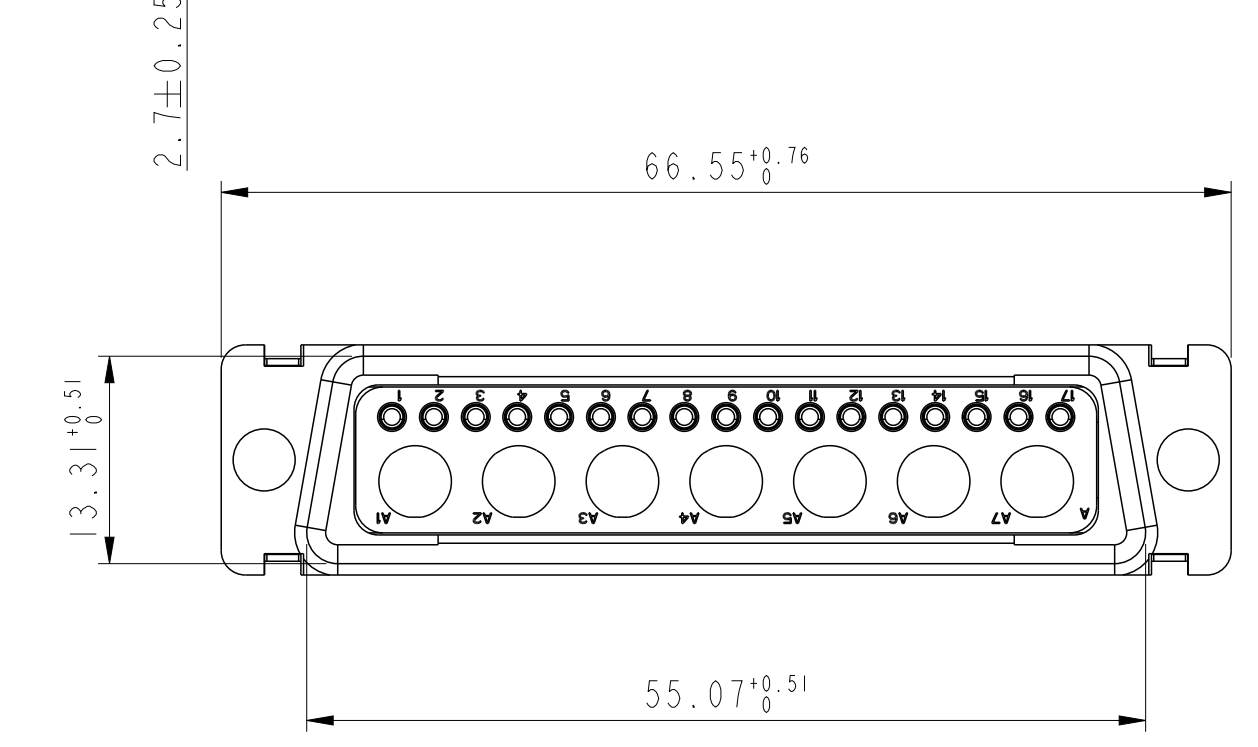
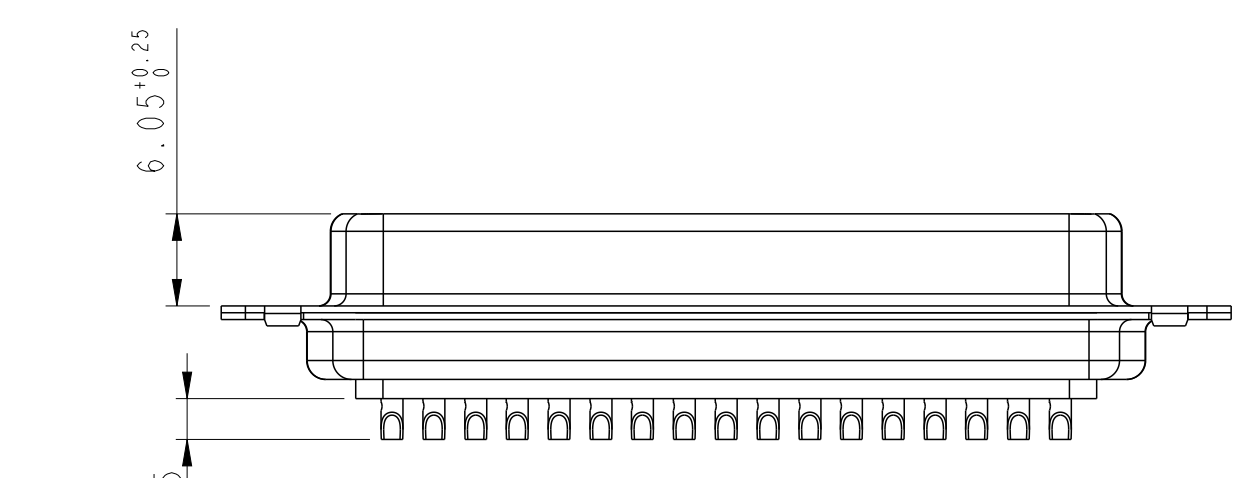
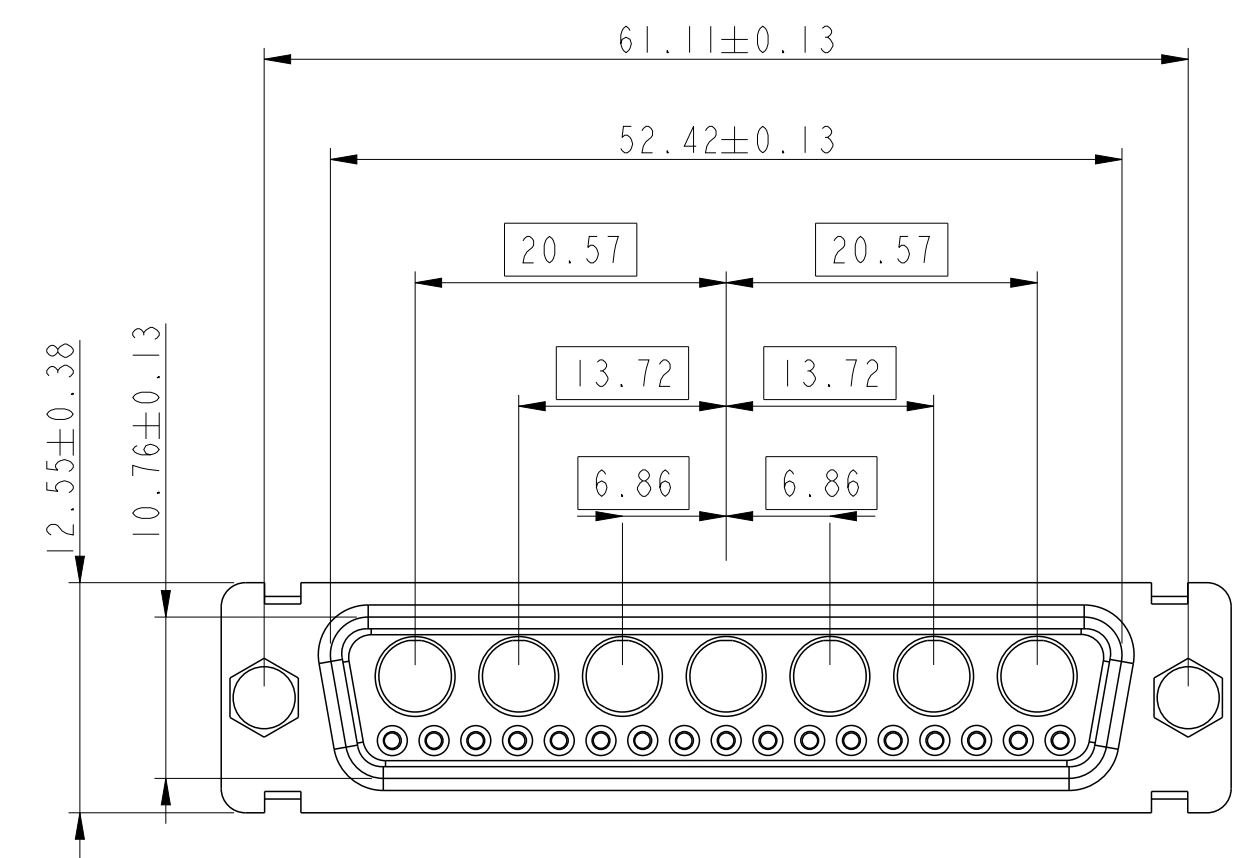
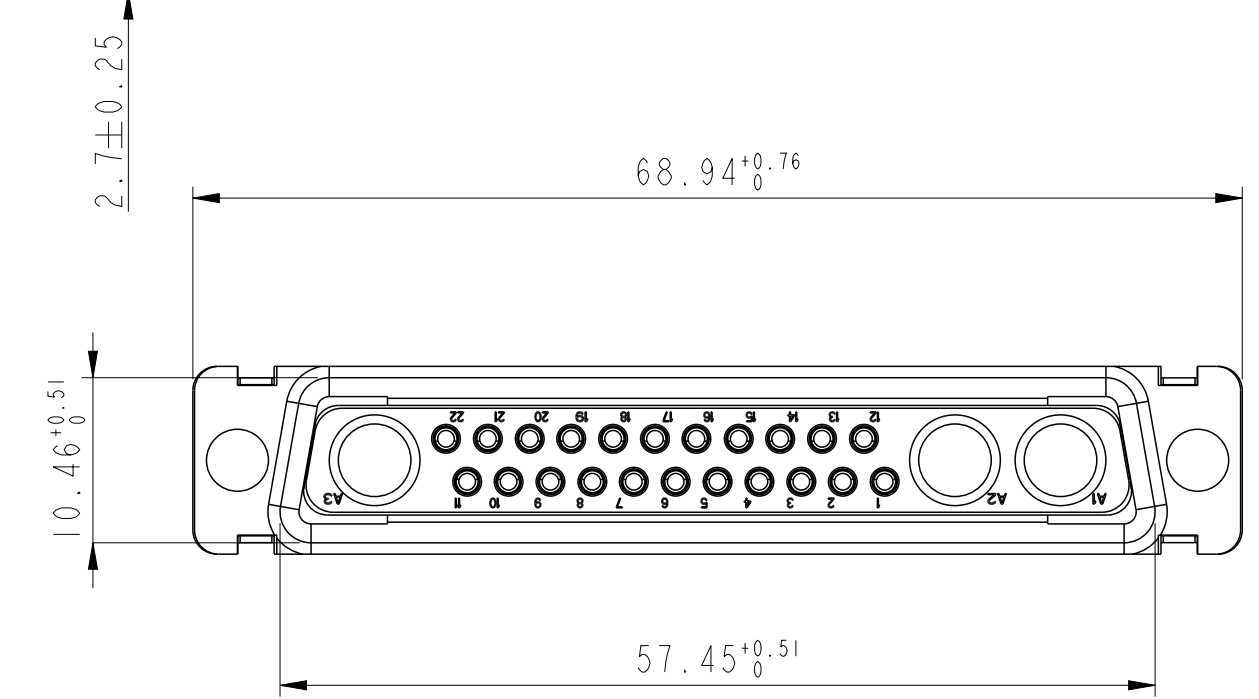
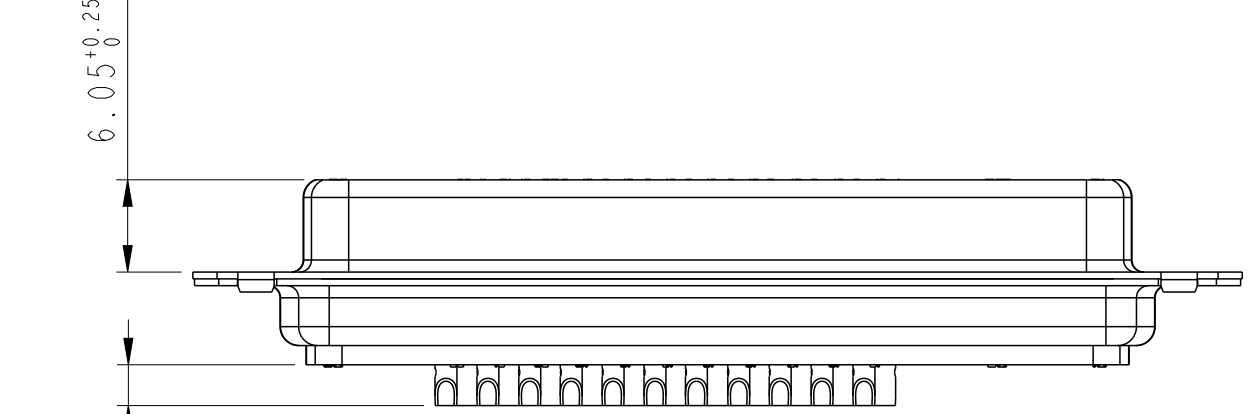
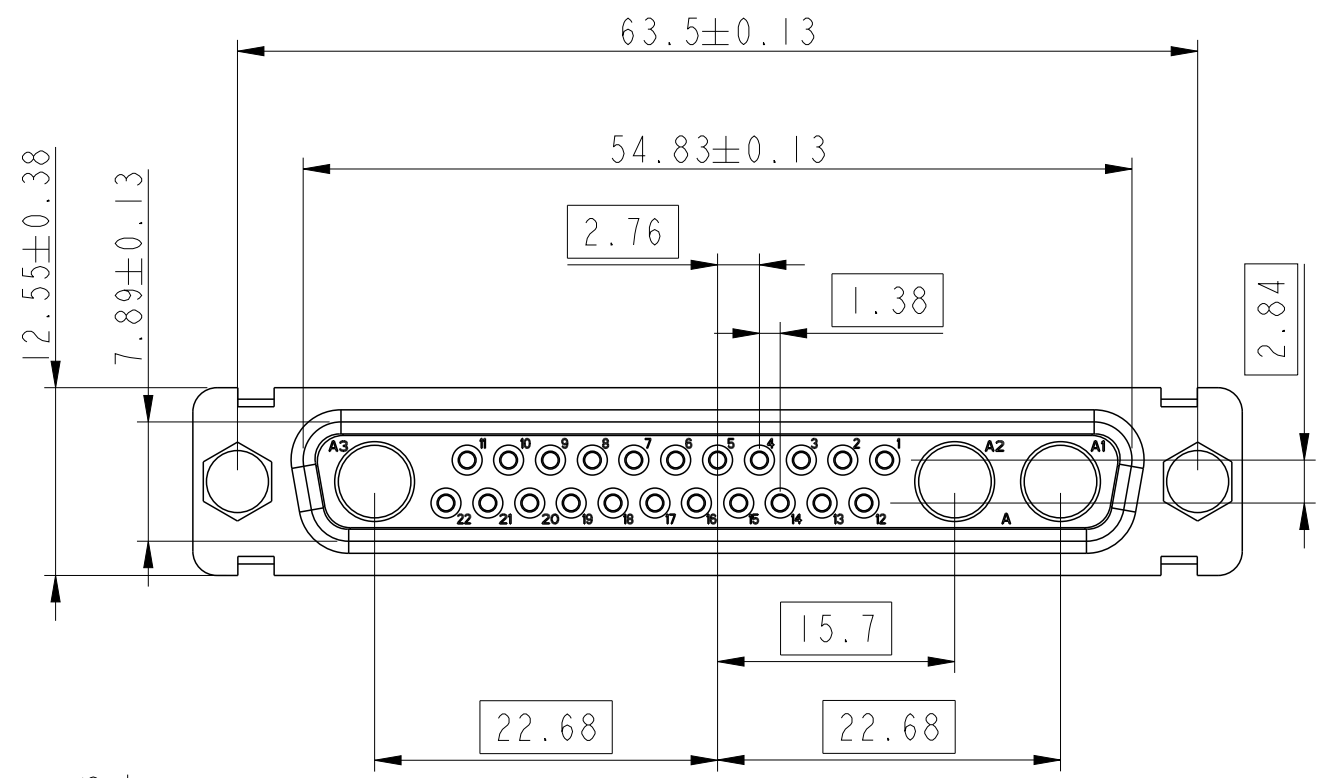

Amphenol FCI

© 2016 AFCI

spec ref	dr	1, Product Eng	2015/06/12	projection	MM	size	A2	scale	2:1
tolerance std	eng	Gregar Mathew	2019/11/11			ecn no	ELX-33002-1	rel level	Released
ISO 1101 ISO 406	chr	-	product family						
surface	linear	0.X	±0.30		title SUB FEMALE DW MIXED POWER + SOLDER BUCKET	dwg no C01-8639-2303	rev E	cat. no. -	Product - Customer Drw
		0.XX	±0.10						
ISO 1302	angular	0°	±2°	PDS: Rev :E		STATUS:Released		Printed: Nov 12, 2019	

36W4

47W1

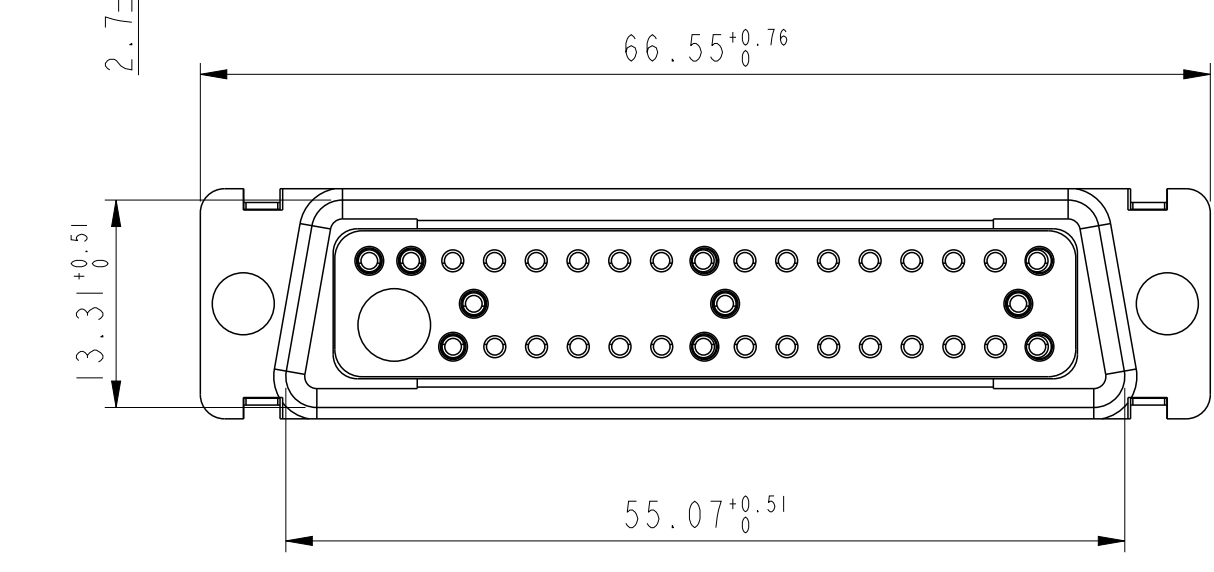
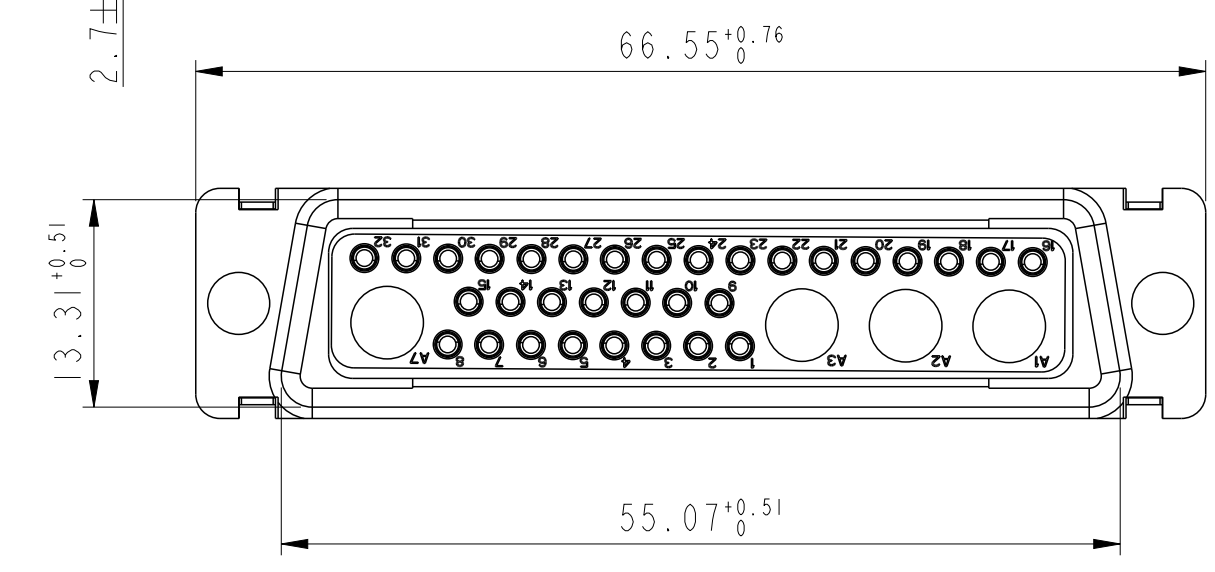
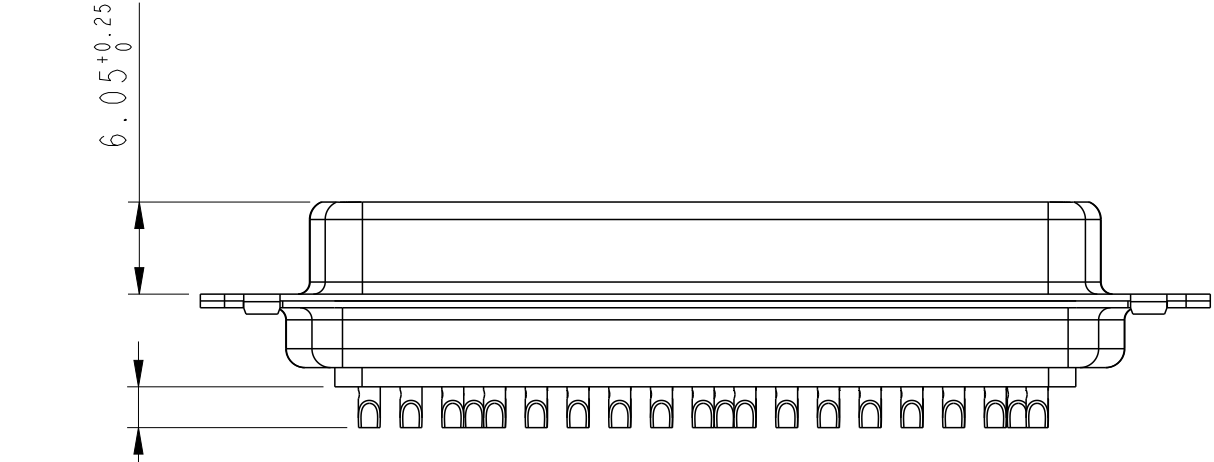
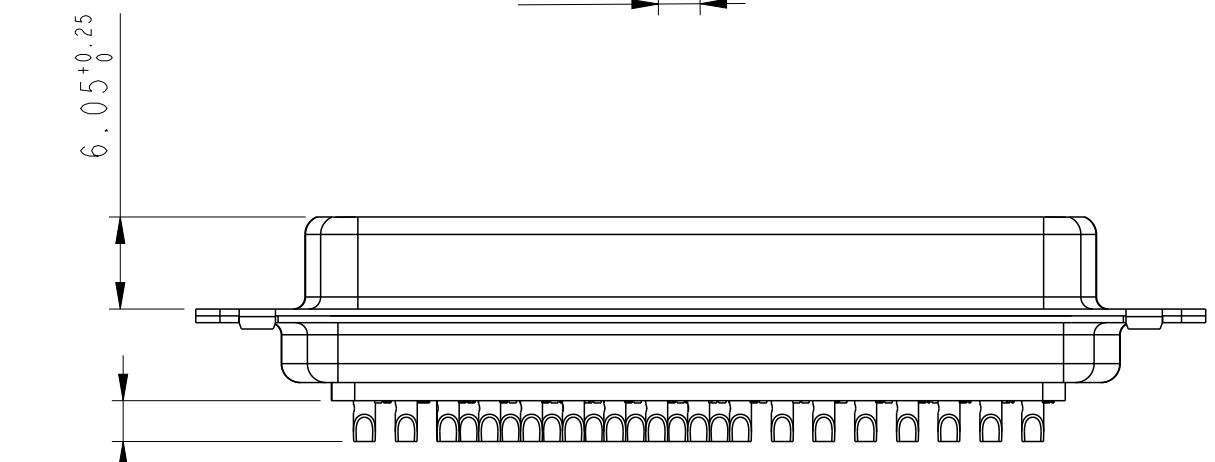
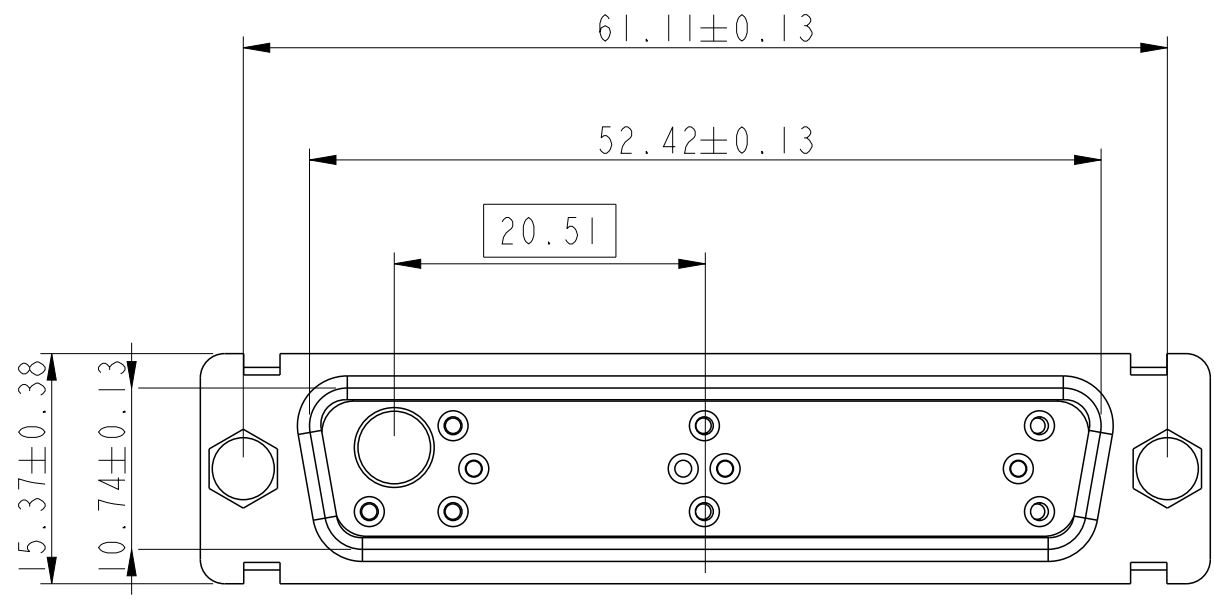
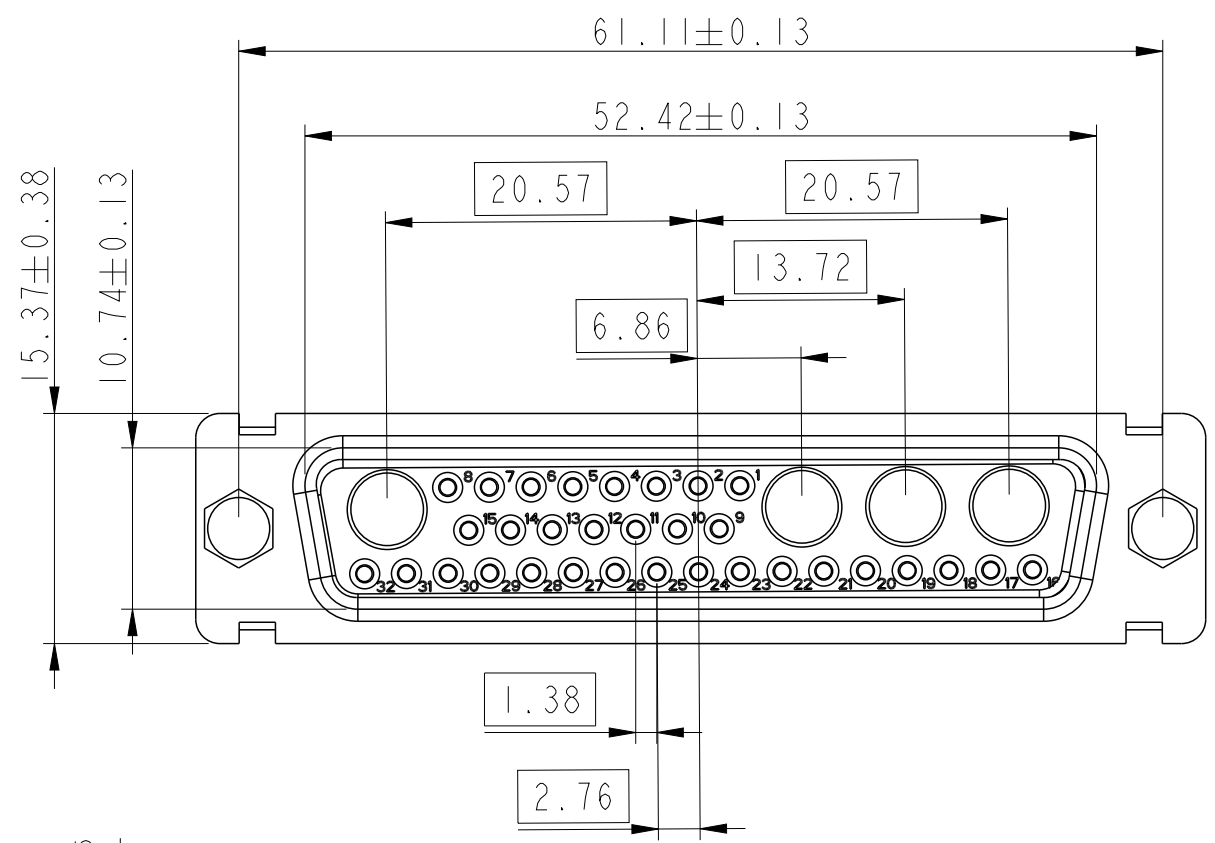

Floating signal contacts

Amphenol FCI

© 2016 AFCI

spec ref	dr	1, Product Eng	2015/06/12	projection	MM	size	A2	scale	2:1
tolerance std	eng	Gregar Mathew	2019/11/11			ecn no	ELX-433002-1	rel level	Released
ISO 1101 ISO 406	chr	-	appr						
surface	linear	0.X	±0.30			title	SUB FEMALE DW		rev
ISO 1302		0.XX	±0.10			title	MIXED POWER + SOLDER BUCKET		rev
	angular	0°	±2°			cat. no.	-	Product - Customer Drw	sheet 7 of 7

PDS: Rev :E

STATUS:Released

Printed: Nov 12, 2019