

DCmind Brushless Motor Datasheet

80 360 001 SMI22 with CAN

Series 80 360 SMI22 CAN

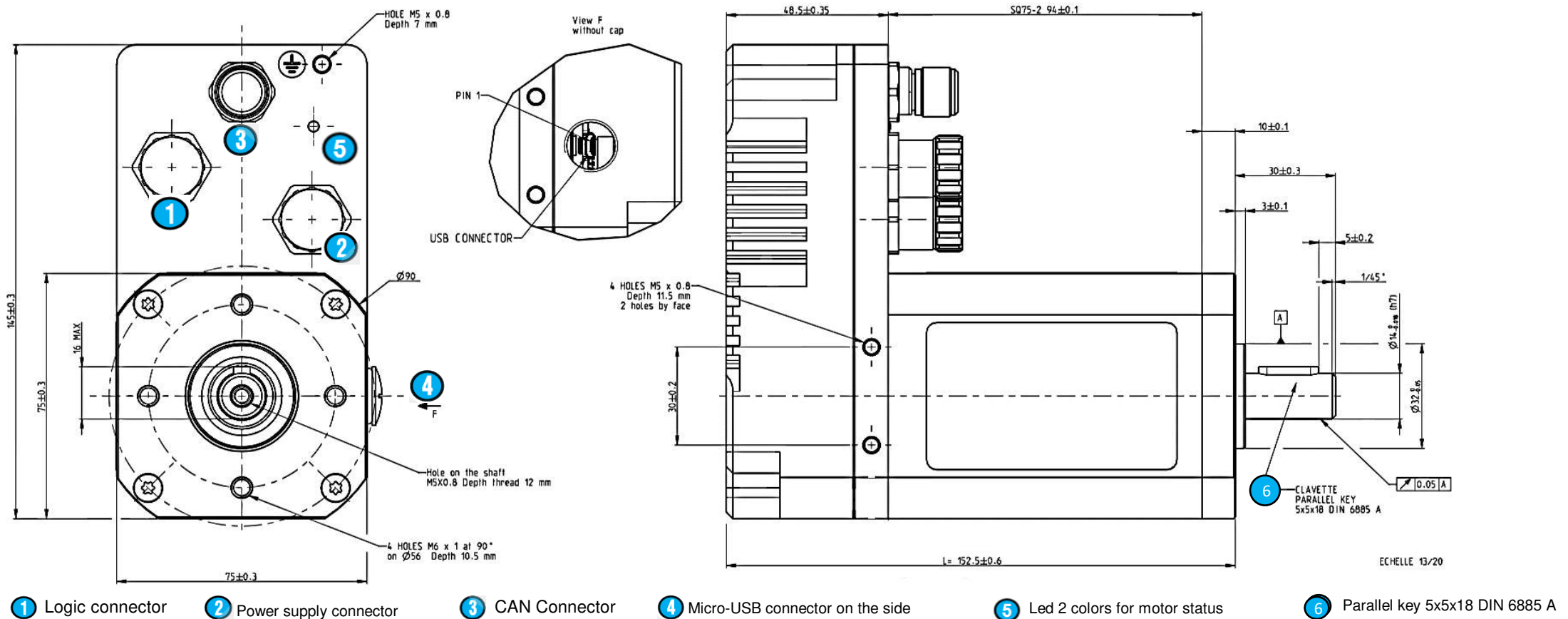

General characteristics

| Power supply | | |
|-------------------------------|-----|---------|
| Direct current voltage supply | | ✓ |
| Nominal voltage range | Vdc | 9 -> 75 |
| Max. current | A | 75 |

| Motor characteristics (1) | 24 Vdc | 32 Vdc | 48 Vdc | |
|---------------------------------|--------|--------|--------|-------------|
| At no load | | | | |
| Max. output speed | rpm | 2 601 | 3 270 | 5 000 |
| Current at the max output speed | A | 1 | 1 | 0,9 |
| Standby current | mA | 50 | 50 | 50 +-10% |
| At nominal | | | | |
| Speed | rpm | 2 230 | 2 960 | 4 540 +-10% |
| Torque | N.m | 1,3 | 1,3 | 1,3 |
| Output power | W | 304 | 403 | 618 +-10% |
| Current | A | 14,4 | 14,4 | 14,4 |
| Efficiency | % | 85 | 87 | 87 |
| At max. output power | | | | |
| Speed | rpm | 1 650 | 2 160 | 3 540 |
| Torque (2) | N.m | 4 | 4 | 4 |
| Output power | W | 691 | 905 | 1 483 |
| Current | A | 42 | 42 | 42 |
| Efficiency | % | 67 | 69 | 71 |
| At peak torque | | | | |
| Speed | rpm | 1 650 | 2 160 | 3 540 |
| Torque | N.m | 4 | 4 | 4 |
| Output power | W | 691 | 905 | 1 483 |
| Current | A | 42 | 42 | 42 |

| Others | | |
|----------------|------------------|--------|
| Life | h | 20 000 |
| Rotor inertia | gcm ² | 536 |
| Rotor poles | | 8 |
| Cogging torque | mNm | 50 |
| Weight | kg | 2,7 |
| Noise level | dBA | 55 |

| Connecting | | |
|---|---------------|--|
| Input/Output M16 connector - 18 pins | Pin N° | |
| Optional logic supply | 1 | |
| 0 Volt | 2 | |
| Input 6 (analogic 1) | 3 | |
| Input 5 (analogic 2) | 4 | |
| Input 1 (digital) | 5 | |
| Input 2 (digital) | 6 | |
| Input 3 (digital) | 7 | |
| Input 4 (digital) | 8 | |
| 0 Volt | 9 | |
| Output 1 (digital - PWM) | 10 | |
| Output 2 (digital - PWM) | 11 | |
| Output 3 (digital) | 12 | |
| Output 4 (digital) | 13 | |
| 0 Volt | 14 | |
| STO2 - | 15 | |
| STO2 + | 16 | |
| STO1 - | 17 | |
| STO1 + | 18 | |
| Power supply M16 connector 3 pins | Pin N° | |
| Output ballast | 1 | |
| +VDC | 2 | |
| 0 Volt | 3 | |
| CAN M12 connector - 5 pins | Pin N° | |
| Not connected | 1 / 2 | |
| 0V - ground | 3 | |
| CAN High | 4 | |
| CAN Low | 5 | |

| Drive | |
|---------------------------------------|---------------------|
| Type | SMI22 CAN |
| Built-in drive | ✓ |
| Internal magnetic encoder | 4096 pulses/rev |
| Setting software on PC | DCmind soft+CANopen |
| Control | |
| Position - speed - torque | ✓ |
| 4 quadrants | ✓ |
| With regenerative energy absorber (3) | ✓ |
| Type" Field Oriented Control" | ✓ |
| Security | |
| Wrong polarity from power supply | ✓ |
| Output shortcut | ✓ |
| Input inverted | ✓ |
| Low voltage | Vdc < 9 |
| Overvoltage (4) | Vdc > 75 |
| Internal drive temperature protection | °C 110 |
| Temperature drive allowing to restart | °C 90 |

| Generic parameters | | | |
|---|----------------|----------|-------------|
| Output shaft with ball bearings | | ✓ | |
| 2 Safe Torque Off inputs IEC61800-5-2/62061, ISO13849 | | ✓ | |
| Max. Radial force (16mm from front face) | N | | 140 |
| Max. axial force | N | | 47 |
| Temperature range | IEC60068-2-1/2 | °C | -30 -> +70 |
| Storage temperature | | °C | -40 -> +80 |
| Dielectric (1s/2mA) | UL1004-1 | Vdc | 1 955 |
| Motor insulation | IEC60085 | class | E |
| Salt spray | ISO9227 | severity | 48h |
| Degree of protection (output shaft not included) | IEC60529 | | IP67 + IP69 |

| EMC | | | |
|--|--------------|-------|---|
| Electrostatic Discharge | IEC61000-4-2 | level | 3 |
| Radiated field | IEC61000-4-3 | level | 3 |
| Electrical fast transient / burst test | IEC61000-4-4 | level | 3 |
| Surge test | IEC61000-4-5 | level | 1 |
| Conducted disturbances | IEC61000-4-6 | level | 3 |
| Radiated emission | EN55022 | class | B |

| Approvals | | | |
|--|-------------------|-------------|------|
| ROHS | 2011/65/CE | ✓ | |
| EC | | ✓ | |
| UL | | Pending | |
| CAN Open | CIA 301 - DSP 402 | ✓ | |
| Communication | | | |
| USB (Setting, monitoring) | | Micro-USB B | |
| CAN open: address - node ID (factory settings) | | 0x20 | |
| CAN open: baud rate (factory settings) | | kbaud | 1000 |

| Notes | |
|--|--|
| Values without tolerances, are average production values. | |
| (1) Cold motor, 20 ° C ambient temperature, full speed, sinusoidal commutation | |
| (2) Max torque for continuous operation at 20 °C, decrease this value for higher ambient temperature | |
| (3) Ballast resistor to be added | |
| (4) Can be configured via DCmind soft+CANopen | |

Additional information is available in the SQ75 product user manual and in the starter kit manual, available in www.crouzet.com

Specifications subject to change without notice. Updated May 27th, 2019

Drive electrical data

| Running datas | | | | |
|--|-----|------|---------|------|
| Parameters | | Min. | Typical | Max. |
| Voltage power supply "Vdc" | Vdc | 9 | 32 | 75 |
| Current "Idc" | A | - | 15 | 60 |
| Standby power "Wo" | W | - | 2 | - |
| Voltage optional logic supply (see wiring diagram) | Vdc | 9 | - | 36 |

| CAN Bus characteristics | | | | |
|-------------------------|-----|------|---------|------|
| Parameters | | Min. | Typical | Max. |
| CAN_L insulated | Vdc | 0,5 | 1,5 | 2,25 |
| CAN_H insulated | Vdc | 2,75 | 3,5 | 4,5 |

Accessories

| Starter kit | | | | |
|--|-------------------|-----------|-------|--|
| Part number | 79 513 105 | | | |
| Power/logic/CAN 3 m cables - Software - USB to Can Open adapter - CAN terminal resistor - CAN double connector | | | | |
| Power supply cable | 79 298 664 | 3m length | AWG18 | |
| Input-Output cable | 79 513 106 | 3m length | AWG24 | |
| CAN cable M12 | 27 358 015 | 1m length | AWG26 | |

| Input datas | | | | |
|------------------|------------|------|---------|------|
| Parameters | | Min. | Typical | Max. |
| Input 1, 2, 3, 4 | Impedance | kΩ | - | 247 |
| | Low level | Vdc | -90 | - |
| Input 5, 6 | High level | Vdc | 4,5 | - |
| | Impedance | kΩ | - | 159 |
| Inputs STO | Low level | Vdc | -90 | - |
| | High level | Vdc | 7,1 | - |
| Inputs STO | Low level | Vdc | -2 | - |
| | High level | Vdc | 4,6 | - |

| Output datas | | | | |
|-------------------------------|------|------|---------|------|
| Parameters | | Min. | Typical | Max. |
| Low level Output 1, 2, 3, 4 | mVdc | - | - | 10 |
| High level Output 1, 2, 3, 4 | Vdc | - | 4,75 | - |
| Max output current "I outmax" | mA | - | - | 50 |
| I sink | mA | - | - | 600 |

Speed-torque and current-torque curves

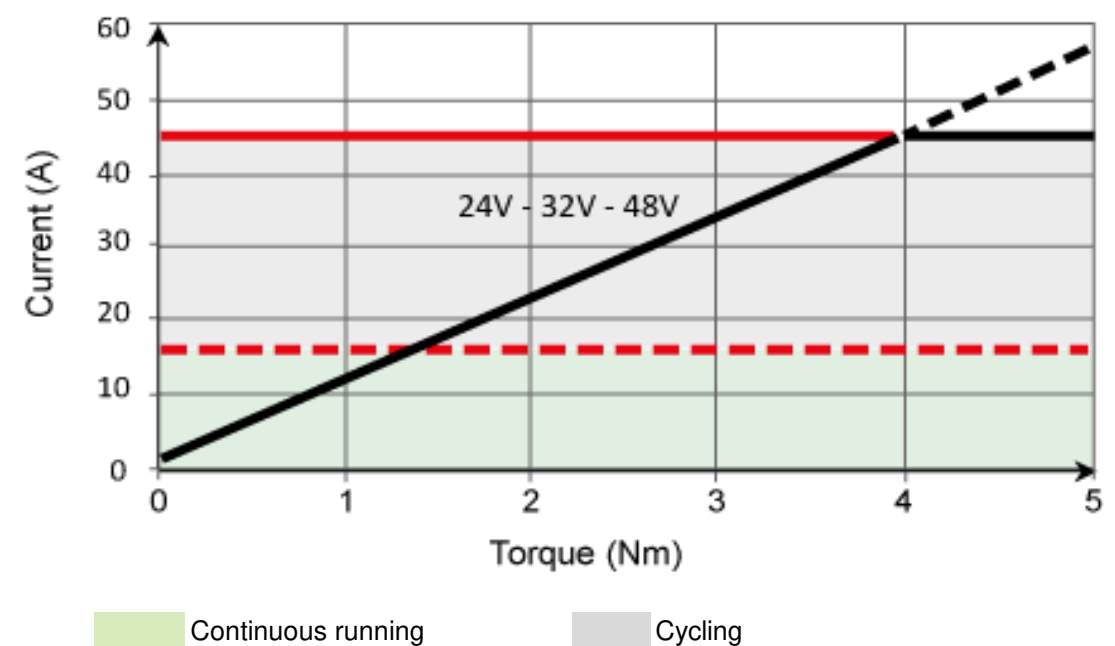
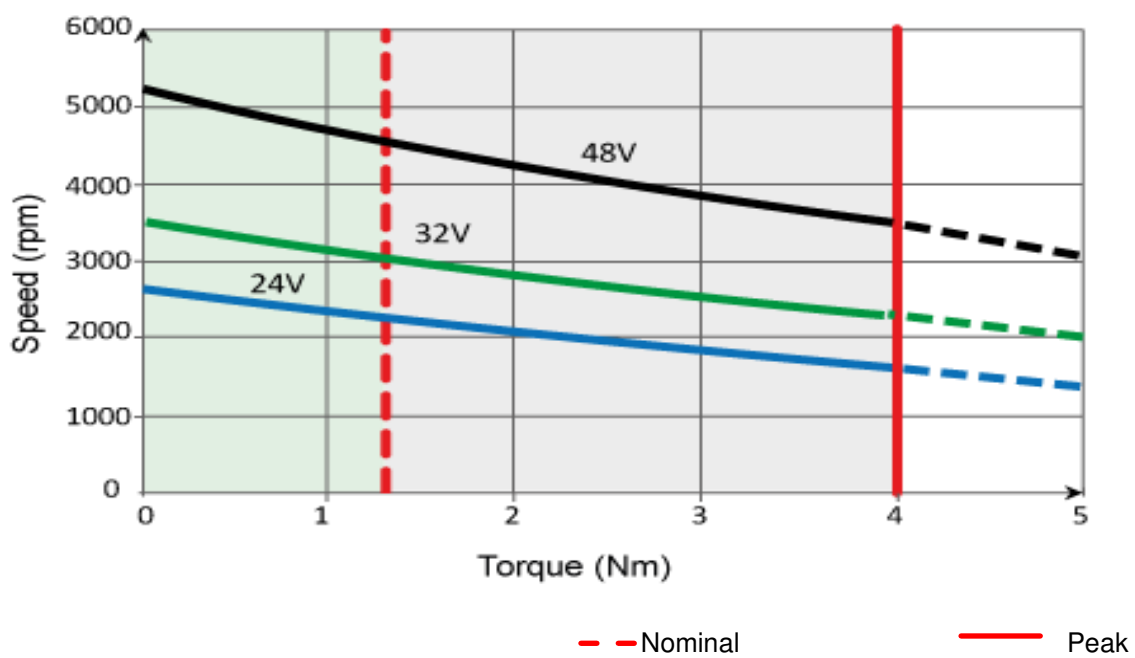

Wiring

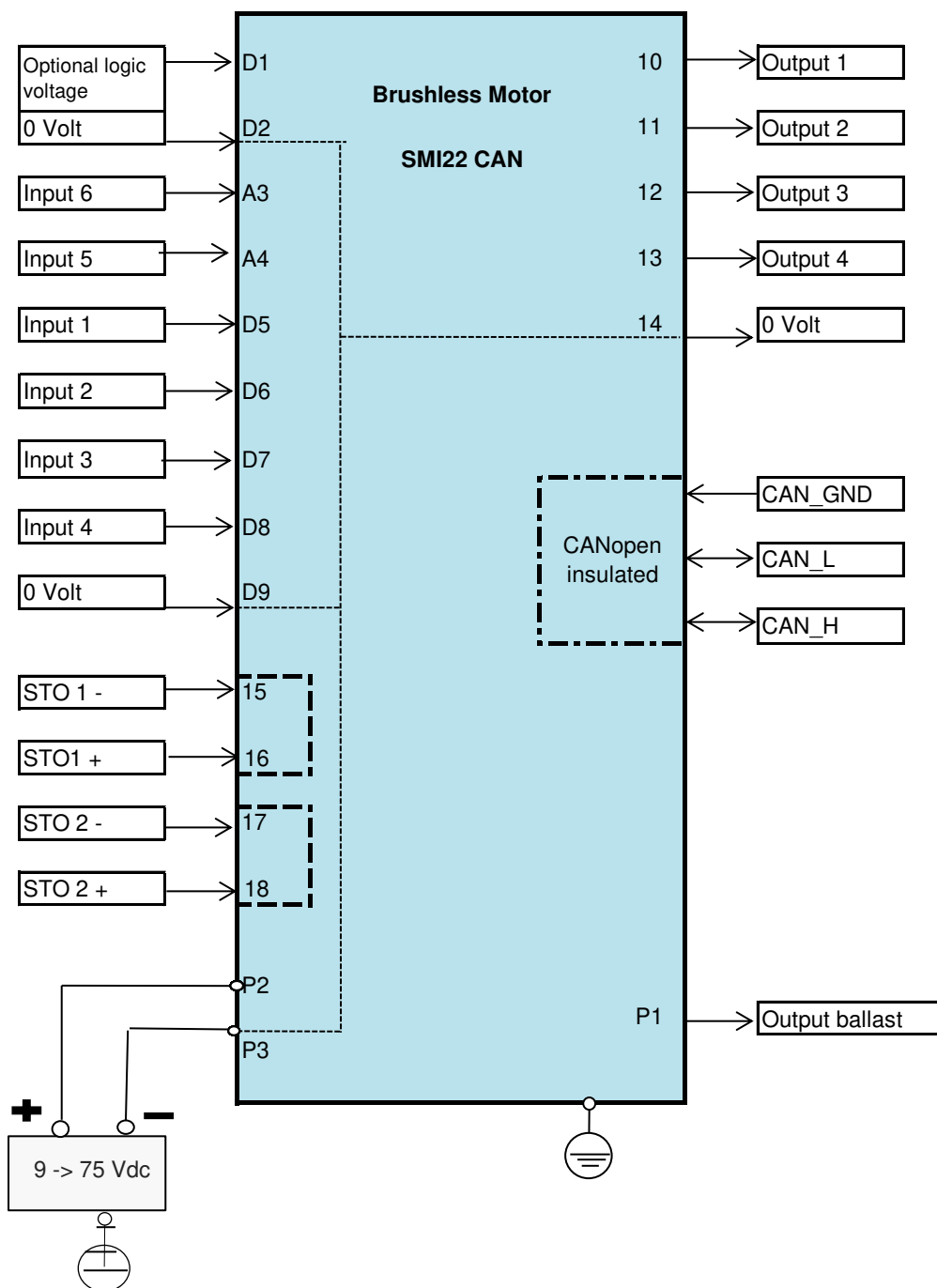

Input equivalent circuit

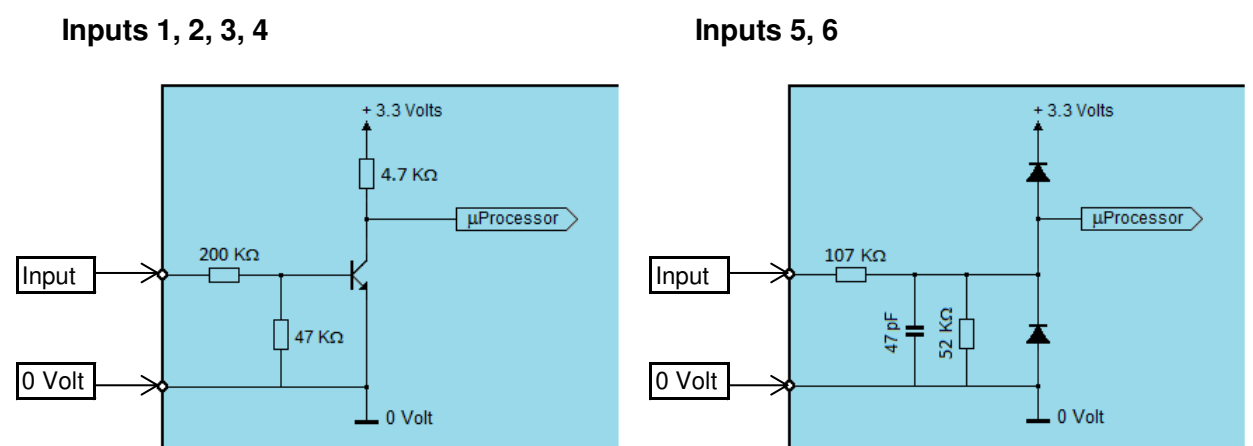

Output equivalent circuit

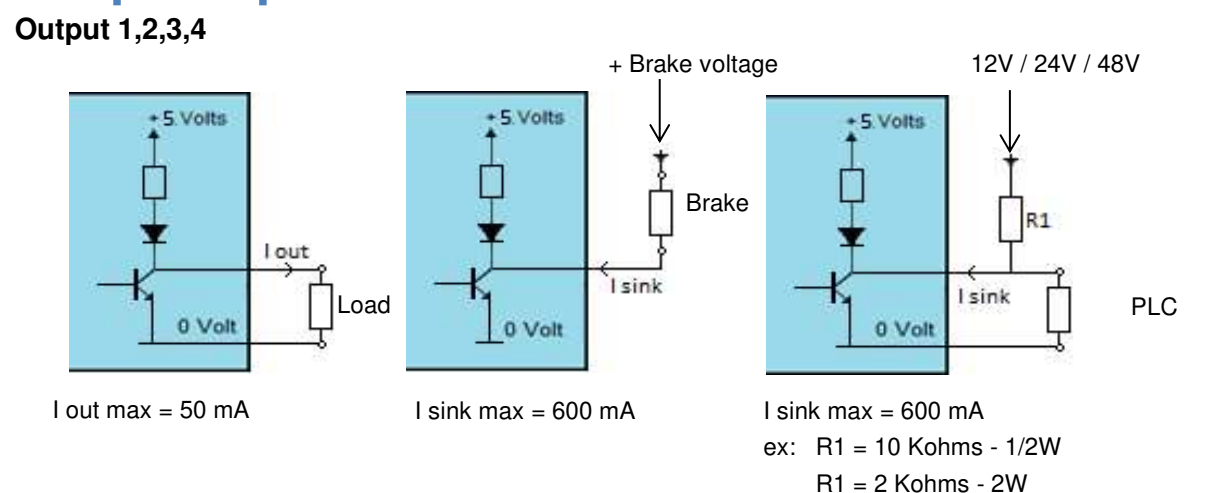

Output ballast

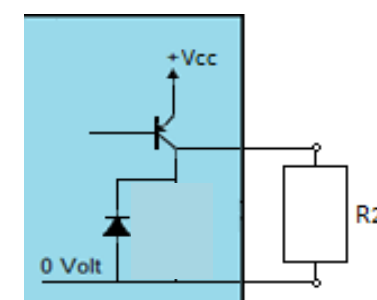

Regenerative energy created per inertia load creates over-voltage. In case of too high value, connect R2 resistor through ballast output and ground to absorb this energy. Typical R2 value is 2.2 Ω. Power value depends from machine inertia. Max. voltage can be set.

Specifications subject to change without notice. Updated May 27th, 2019