

Ha-VIS eCon 3000

Full Gigabit Ethernet Basic

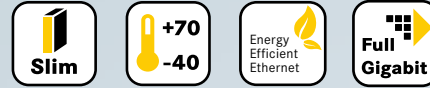

2 to 16 Ethernet ports RJ45 and SC/LC (SFP)
 Unmanaged Plug & Play Ethernet switches for DIN rail assembly in control cabinets
 Commercial Temp.: 0 °C ... +55 °C / Industrial Temp.: -40 °C ... +70 °C



- Full gigabit Ethernet, non-blocking switch architecture acc.to IEEE 802.3
- Support of jumbo frames
- Variants with industrial temperature range of -40°C ... +70 °C
- Wide range voltage supply 24/48 VDC
- Surge protection and reverse polarity protection
- Minimum energy consumption due to Energy-Efficient Ethernet
- Optimised DIN rail bracket

Target markets

Machinery & Robotics	Automation technology	Industrial network infrastructures
Wind Energy Solar Energy	Transportation	Shipbuilding



General description

The Ha-VIS eCon 3000 Full Gigabit family of unmanaged Ethernet switches is equipped with up to 16 gigabit Ethernet ports and allow for cost-efficient and quick expansion and/or reconstruction of network infrastructures with high bandwidth requirements. In this, all switches support extra-long Ethernet frames (jumbo frames). The slender design of the switches enables an extremely high packing density on the DIN rail. Various combinations of

variants with RJ45, fibre optic cables and SFP ports are available. Automatic detection of the transmission rate (auto-negotiation) and of the wiring of the twisted pair data cable (autopolarity and auto-MDI(X)) allow for simple plug & play. All variants are available with the temperature ranges „Industrial“ and „Commercial“.

Technical characteristics

Switch Features

Enclosures width	25 mm	38 mm
Number of ports	2, 5, 6, 7	16
Switching technology	Store and Forward	
Supported standards	IEEE 802.3	
Frame Size	10 kbytes	8 kBytes
MAC table size	8k entries	
Packet buffer size	1 Mbit	512 kBytes
Non-blocking	Yes	
Quality of service	Yes	
Energy-Efficient Ethernet	Yes	
PROFINET compatible	Yes	
EthernetIP compatible	Yes	

Voltage supply

Nominal voltage	24 VDC	48 VDC
Permissible voltage range (see table techn. characteristics)	9 VDC ... 60 VDC	... *
Surge protection	Yes	
Reverse polarity proof	Yes	
Starting current	1.60 A	3.20 A
Overcurrent protection at input	Yes (12 A for <=8 ports) / (2 A for >8 ports)	
Max. power consumption @ 24 VDC	2.21 W ... 9.17 W	
Cross-section / Wire gauge	0.08 mm ² ... 2.5 mm ² (28 AWG ... 12 AWG)	
Connection type	3-pole, pluggable screwed contact	
Pinout	+ / - / ⚡	
Supply circuit (acc. to 60950)	SELV (circuit breaker 10 A)	

Ethernet Ports 10BASE-T_e / 100BASE-TX EEE / 1000BASE-T EEE

Connection type	RJ45
Auto-negotiation	Yes
Auto-polarity	Yes
Auto-MDI(X)	Yes
Transfer conditions	Twisted Pair
Transfer speed	10 / 100 / 1000 Mbit/s
Transfer length	100 m (twisted pair, Cat 5)

Ethernet Ports 1000BASE-SX / 1000BASE-LX

Type of fibre	Multimode (MM)	Singlemode (SM)
Connection type	SC Duplex	
Transfer conditions	FO	
Wavelength	850 nm	1310 nm
Transfer speed	1000 Mbit/s	
Transfer length	0.55 km	10 km
Output power	-9.5 dBm ... -4 dBm	-9.5 dBm ... -3 dBm
Input sensitivity	≤ -17 dBm	≤ -21 dBm

SFP ports

Transfer standard	Depending on used SFP
Connection type	Depending on used SFP, RJ45 or LC
Transfer conditions	Depending on used SFP, TP or FO
Transfer speed	Depending on used SFP, 100 or 1000 Mbit/s
Transfer length	Depending on used SFP



HARTING Technology Group
 P.O.Box 1473, D-32325 Espelkamp
 Wilhelm-Harting-Straße 1, D-32325 Espelkamp, Germany

ICPN-Service@harting.com | Service hotline: +49 5772 47-9479
 Fax: +49 5772 47-495 | www.HARTING.com/de/ethernet-switches

Note: We reserve the right to make technical changes to the products and to the content of this document at any time without prior notification. The HARTING Technologiegruppe does not accept any responsibility for possible errors or incompleteness in this document. We reserve all the rights to this document and the topics and illustrations contained within it. Copying, disclosure to third parties or use of its content - even partially - is forbidden without the prior written consent of the HARTING Technologiegruppe.

Enclosures

Enclosures width	25 mm	38 mm
Dimensions H x W x D (without pluggable screw contact and holding bracket)	142 mm x 25 mm x 107.5 mm	142 mm x 38 mm x 107.5 mm
Weight	428 g ... 490 g	700 g
Type of installation	35 mm DIN rail acc. to EN 60 715	
Material enclosures	Anodised aluminium / Powder-coated steel sheet	
Protection degree (with plugged screw contact)	IP30	
Protection class	III	

Status and diagnostic displays

Power („Pwr“) lights up green	Supply voltage is applied
Link/Activity („L/A“) off	No link
Link/Activity („L/A“) lights up green	Link is active
Link/Activity („L/A“) flashes green	Link is active and data is transferred
Link speed („Spd“) off	10 Mbit/s
Link speed („Spd“) lights up yellow	100 Mbit/s
Link speed („Spd“) lights up green	1000 Mbit/s

Ambient conditions

Commercial temperature range	0 °C ... +55 °C
Industrial temperature range	-40 °C ... +70 °C
Storage temperature range	-40 °C ... +85 °C
Relative humidity (operation)	0 % ... 95 % (not-condensing)
Relative humidity (storage and transport)	0 % ... 95 % (not-condensing)
Air pressure (operation)	2000 m (795 hPa)

Approvals

CE, FCC CFR 47 Part 15, cUL US 508 listed, DNV GL, LR, NK, ABB IIT

EMC and environmental conditions

EMC Interference immunity (EN 61000-6-1, 61 000-6-2 55024)

Electrostatic discharge (ESD) EN 61 000-4-2
 Electromagnetic field EN 61 000-4-3
 Rapid transients (burst) EN 61 000-4-4
 Surge voltages EN 61 000-4-5
 Conducted interference voltages EN 61 000-4-6

EMC Interference emission (EN 61000-6-4, EN 55 032, FCC CFR 47 Part 15)

Mechanical stability (EN 60721-3)

IEC 60068-2-6 Vibration
 IEC 60068-2-6 Vibration resonance search
 IEC 60068-2-27 Shock test

Included in delivery

- Pluggable screw contact for voltage supply
- Assembly instruction

Drawings

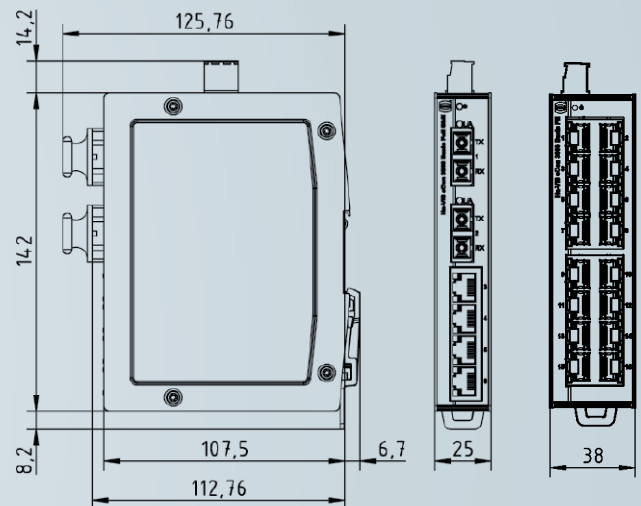

Technical characteristics / order information

Ports / order information

RJ45	SFP	SC	Enclosures width	Current consumption @ 24 VDC	MTBF in Mio. h	Commercial Temp.: 0 °C ... +55 °C		Industrial Temp.: -40 °C ... +70 °C	
						Switch	Part no.	Switch	Part no.
1	-	1x MM (0.55 km)	25 mm	92 mA*	2.13	Ha-VIS eCon 3011GB-AD	24 03 401 1110	Ha-VIS eCon 3011GBT-AD	24 03 401 1100
1	-	1x SM (10 km)	25 mm	92 mA*	2.13	Ha-VIS eCon 3011GB-AF	24 03 401 1210	Ha-VIS eCon 3011GBT-AF	24 03 401 1200
1	1	-	25 mm	90 mA**	0.95	Ha-VIS eCon 3011GB-AC	24 03 401 1310	Ha-VIS eCon 3011GBT-AC	24 03 401 1300
4	-	1x MM (0.55 km)	25 mm	155 mA*	2.15	Ha-VIS eCon 3041GB-AD	24 03 404 1110	Ha-VIS eCon 3041GBT-AD	24 03 404 1100
4	-	1x SM (10 km)	25 mm	155 mA*	2.15	Ha-VIS eCon 3041GB-AF	24 03 404 1210	Ha-VIS eCon 3041GBT-AF	24 03 404 1200
4	-	2x MM (0.55 km)	25 mm	182 mA*	2.08	Ha-VIS eCon 3042GB-AD	24 03 404 2110	Ha-VIS eCon 3042GBT-AD	24 03 404 2100
4	-	2x SM (10 km)	25 mm	182 mA*	2.08	Ha-VIS eCon 3042GB-AF	24 03 404 2210	Ha-VIS eCon 3042GBT-AF	24 03 404 2200
4	3	-	25 mm	172 mA**	0.99	Ha-VIS eCon 3043GB-AC	24 03 404 3310	Ha-VIS eCon 3043GBT-AC	24 03 404 3300
5	-	-	25 mm	149 mA*	1.97	Ha-VIS eCon 3050GB-A	24 03 405 0010	Ha-VIS eCon 3050GBT-A	24 03 405 0000
5	-	1x MM (0.55 km)	25 mm	177 mA*	1.91	Ha-VIS eCon 3051GB-AD	24 03 405 1110	Ha-VIS eCon 3051GBT-AD	24 03 405 1100
5	-	1x SM (10 km)	25 mm	177 mA*	1.91	Ha-VIS eCon 3051GB-AF	24 03 405 1210	Ha-VIS eCon 3051GBT-AF	24 03 405 1200
5	2	-	25 mm	175 mA**	0.94	Ha-VIS eCon 3052GB-AC	24 03 405 2310	Ha-VIS eCon 3052GBT-AC	24 03 405 2300
6	-	-	25 mm	172 mA*	1.76	Ha-VIS eCon 3060GB-A	24 03 006 0010	Ha-VIS eCon 3060GBT-A	24 03 006 0000
6	1	-	25 mm	178 mA**	0.89	Ha-VIS eCon 3061GB-AC	24 03 406 1310	Ha-VIS eCon 3061GBT-AC	24 03 406 1300
7	-	-	25 mm	182 mA**	0.85	Ha-VIS eCon 3070GB-A	24 03 407 0010	Ha-VIS eCon 3070GBT-A	24 03 407 0000
16***	-	-	38 mm	382 mA*	1.36	Ha-VIS eCon 3160GB-A	24 03 416 0010	Ha-VIS eCon 3160GBT-A	24 03 416 0000

* Permissible voltage range 9 VDC ... 60 VDC

** Permissible voltage range 18 VDC ... 60 VDC

*** Maritime Approvals on request