

**Features**

- Build in RC oscillator for sensor signal detection
- On chip shunt regulated power supply
- Using AC 60Hz(PT8A3511)/50Hz(PT8A3512) as timer clock set by user
- Accurate timer with error dropping in  $\pm 1\%$
- Sensitive movement detection
- Powerful immunity of sensor Vibration
- 30s time out for IRON in static horizontal position
- 8min time out for IRON in static vertical position
- LED to indicate operation status
- Usable in both 120V and 240V voltage supply system
- Quick function test mode
- Few external components
- Lead free DIP-8 and SOIC-8 package

**Description**

The PT8A3511/12 are high performance low power and low cost CMOS chips designed for intelligent electric IRON controller. Their intelligence mainly results from their sensitive detection to the movement and static position of electric iron by using a special sensor. With the sensor, these chips can detect the vertical/horizontal position and movement status of IRON.

These chips are equipped with on-chip shunt regulator, sensor signal processor, build-in oscillator, timer, logic control, power on reset and output driving block etc.

**Ordering Information**

Part Number	Package
PT8A3511PE	Lead free DIP-8
PT8A3512PE	Lead free DIP-8
PT8A3511WE	Lead free SOIC-8
PT8A3512WE	Lead free SOIC-8

**Application**

- Electric Iron Controller

**Function comparison table**

Part No	Clock Frequency
PT8A3511	60 Hz
PT8A3512	50 Hz

**Block Diagram**

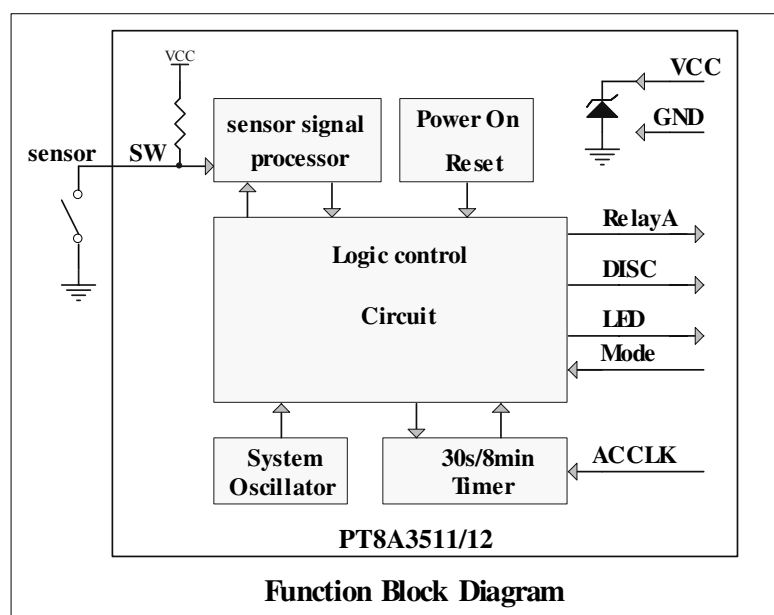

**Pad Assignment**

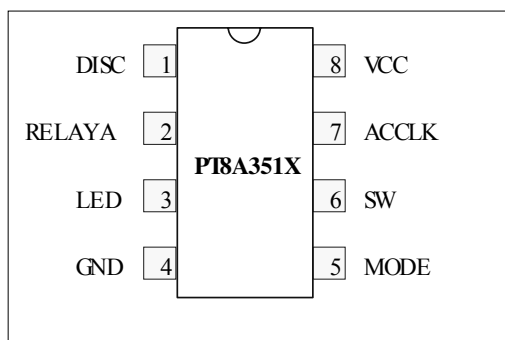

**Pad Description**

Pin No.	Pin Name	I/O	Description
1	DISC	O	Discharge the external electrolytical cap to stabilize and limit its voltage.
2	RELAYA	O	Relay drive output, active high.
3	LED	O	With open drain output, it can shut off external LED in parallel with this open-drain transistor, active low.
4	GND	-	Ground.
5	MODE	I	Test mode select pin, internal pull up.
6	SW	I	Sensor signal input, internal pull up.
7	ACCLK	I	AC 60/50Hz signal for clock with schmitter architecture.
8	VCC	-	Power supply.

**Functional Description (Refer to Block Diagram)**

The chip is comprised of several blocks: on-chip shunt regulator, sensor signal processor, build-in system oscillator, DPLL, 30s/8min timer, logic control circuit, and power on reset, etc. Each block will be described as below.

**Logic control circuit**

Logic control circuit mainly carries out logic control function. It not only collects signals from other blocks, but also generates various driving signals including RELAYA&DISC. Besides, an external LED will flash at about 4Hz after internal timer times out. Signals at RELAYA will control external relay to decide whether IRON heats or not.

**Sensor signal processor**

The core in the whole system is how to correctly detect the position and movement of sensor so that the system can be always under safe control. Thus, it is critical to accurately and correctly deal with signal from sensor in different status and eliminate the noise caused by debounce action from sensor.

Here, we use a unique structure to do the high-requirement signal processing.

In real application of IRON, sensor firstly needs to be installed according to certain requirements (for example its inclination).

**Timer**

Timer block mainly generates various timing signal according to the position of IRON.

It is easy to get accurate timer (30s/8min) by using AC 60Hz for PT8A3511 and 50Hz for PT8A3512 signal as timing reference. As above description, Iron in Horizontal position over 30s will stop heating. While Iron in vertical position over 8min will also stop heating.

**LED**

During heating, LED pin is floating and an external LED will turn on. After times out, LED pin outputs pulse and an external LED will flash at about 4Hz.

## Maximum Rating

Storage Temperature.....	- 40°C to +125°C
Supply Voltage to Ground Potential (Inputs & V <sub>CC</sub> only).....	- 0.5 to V <sub>CC</sub> +0.5V
Supply Voltage to Ground Potential (Outputs & D/O only)...	- 0.5 to V <sub>CC</sub> +0.5V
DC Input Voltage .....	- 0.5V to V <sub>CC</sub> +0.5V
DC Output Current .....	20mA
Power Dissipation.....	500mW

**Note:**

Stresses greater than those listed under MAXIMUM RATINGS may cause permanent damage to the device. This is a stress rating only and functional operation of the device at these or any other conditions above those indicated in the operational sections of this specification is not implied. Exposure to absolute maximum rating conditions for extended periods may affect reliability.

## Recommended Operating Conditions

Symbol	Description	Min	Typical	Max	Unit
V <sub>CC</sub>	Supply voltage	4.5	5	5.5	V
T <sub>A</sub>	Operating Temperature	-10	25	85	°C

## Electrical Characteristics

(T<sub>A</sub> = -10 ~ 85°C, unless otherwise noted)

Symbol	Parameter	Test Condition		Min	Typ	Max	Unit
		V <sub>CC</sub>	Conditions				
V <sub>CC</sub>	Internal shunt regulator voltage	-	-	4.5	5	5.5	V
I <sub>IL</sub>	Input low current (SW)	5V	V <sub>IL</sub> =0V	-30	-	-100	μA
I <sub>OH1</sub>	Output Source Current (RELAYA /Disc)	5V	V <sub>OH1</sub> =2.5V	-0.3	-	-1	mA
I <sub>OL1</sub>	Output Sink Current (RELAYA/DISC)	5V	V <sub>OL1</sub> =0.5V	0.5	-	-	mA
I <sub>OL2</sub>	Output Sink Current (LED)	5V	V <sub>OL2</sub> =0.5V	10	-	-	mA
I <sub>CC</sub>	Power supply current	4V	ACCLK=VCC	-	-	400	μA

**Application Circuit**

**Note:** Suggest the parameter of relay meet the following specification: 24VDC, 1.6KΩ Coil resistance

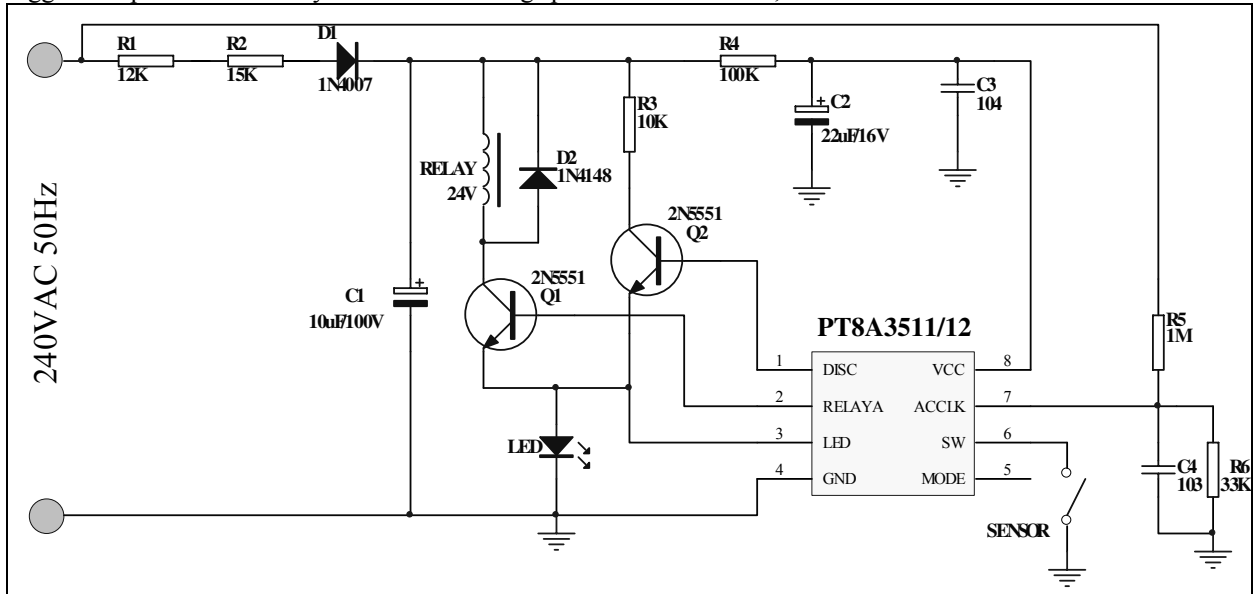

**Figure 1 Typical Application Circuit of PT8A3511/12 240V**

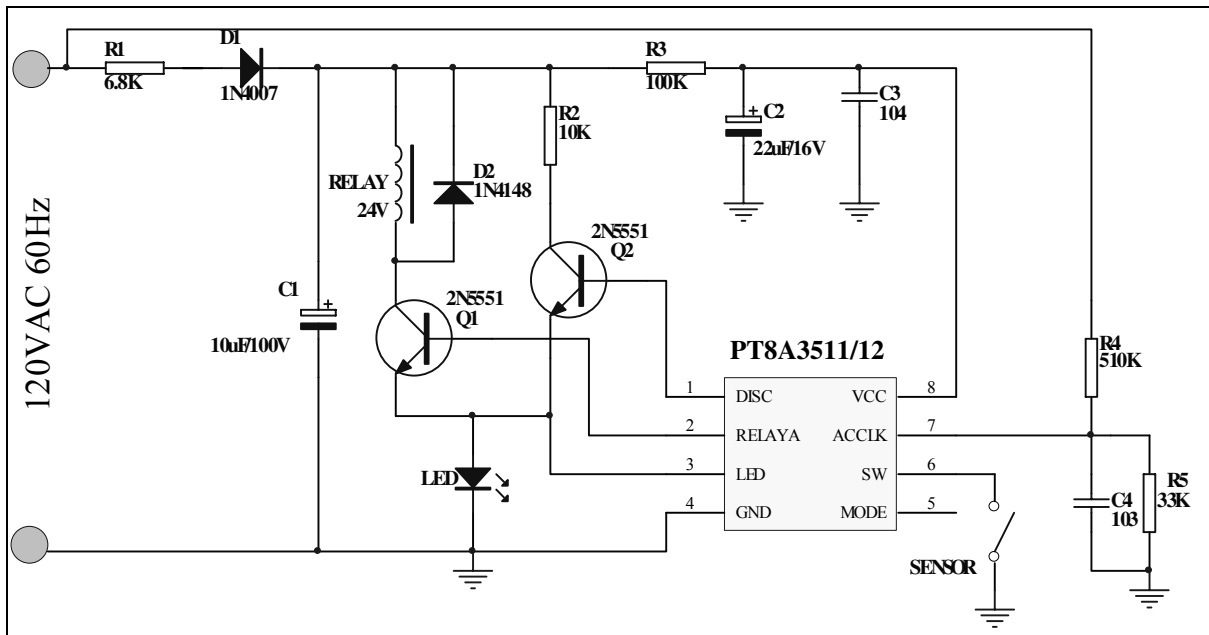

**Figure 2 Typical Application Circuit of PT8A3511/12 120V**

**Mechanical Information**

PE (DIP-8)

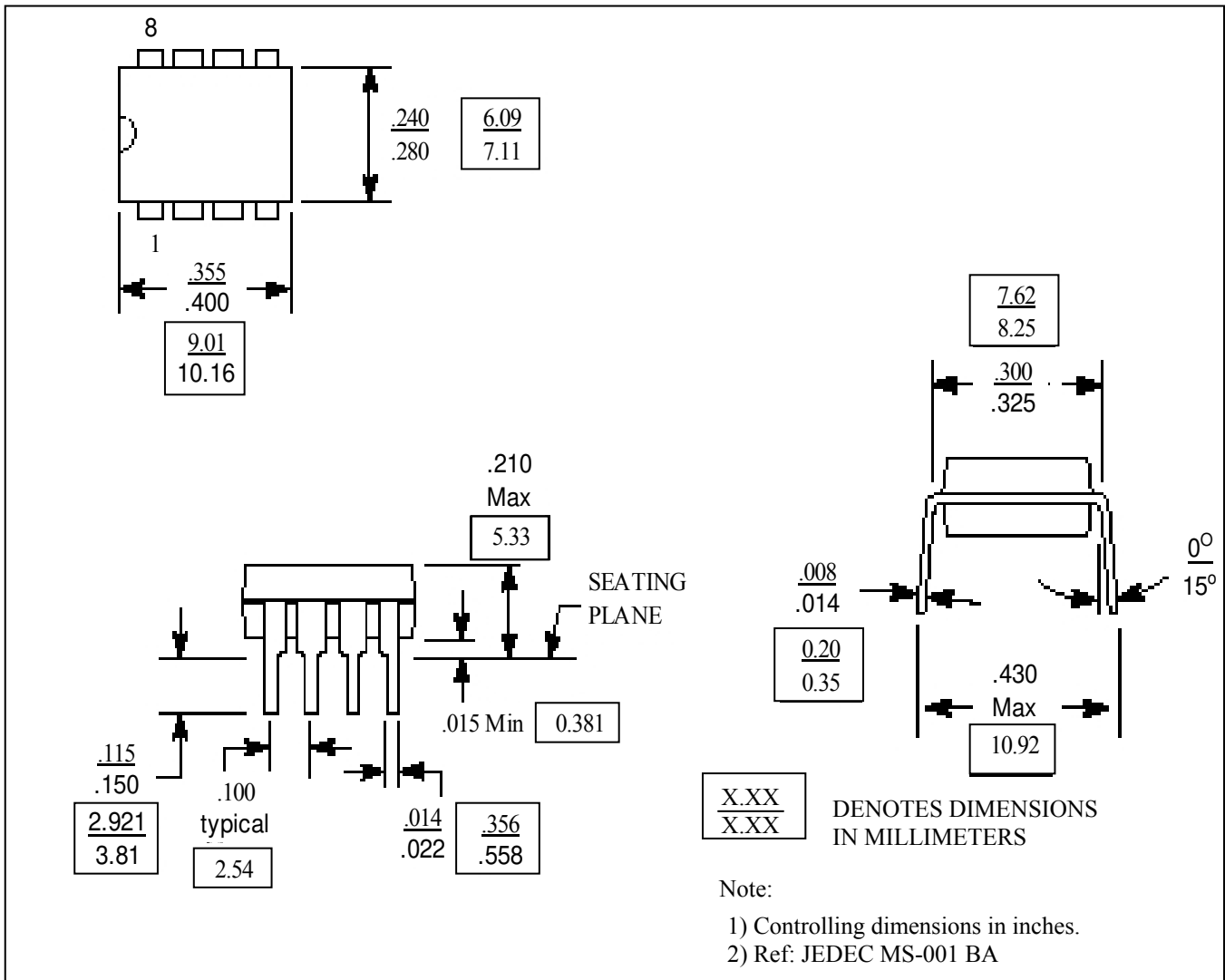

**WE (SOIC-8)**

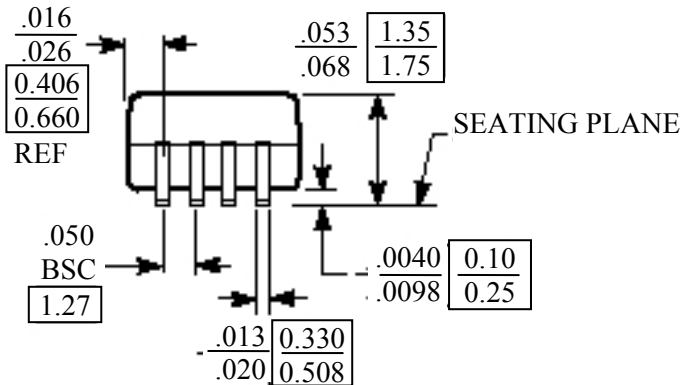
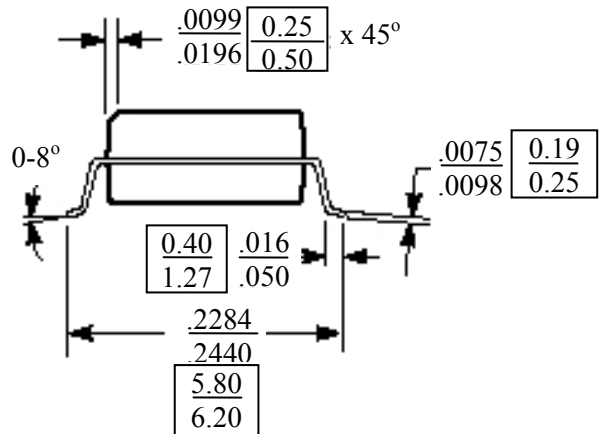
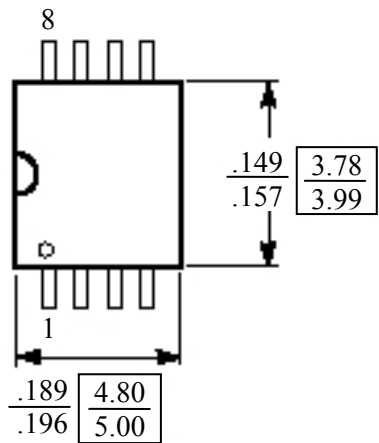

$\frac{X.XX}{X.XX}$  DENOTES DIMENSIONS  
IN MILLIMETERS

- Note:
- 1) Controlling dimensions in millimeters.
  - 2) Ref: JEDEC MS-012 AA