

# "High Frequency Ceramic Solutions"

433 MHz Impedance Matched Balun + LPF Integrated Front-End SMD Passive Component for SiLabs Si4455, Si4460, Si4461, Si4463, and Si4464 Chipsets

P/N 0433BM41A0019

Detail Specification: 5/30/2017

Page 1 of 5

General Specifications	
<b>Part Number</b>	0433BM41A0019
<b>Frequency Range(MHz)</b>	424-444
<b>Balanced Impedance</b>	Si4455, Si4460, Si4461, Si4463, Si4464
<b>Unbalanced impedance</b>	50Ω (single ended)
<b>Average Insertion Loss when connected to Si44XX chipset (Active OP Tx/Rx)</b>	0.9dB Typ@25C 1.5dB max. (-45 to +85C)
<b>Insertion Loss when component measured by itself(passive insertion loss)</b>	1.6dB Typ in Rx, 1.4dB Typ in Tx @25C 2.2dB max. in Rx, 1.9dB max. in Tx (-45 to +85C)
<b>Attenuation dB (min.)</b>	35 min. @ 2xfo MHz
	35 min. @ 3xfo MHz
	35 min. @ 4xfo MHz
	35 min. @ 5xfo MHz
<b>Phase Diff. (deg.)</b>	180° ± 10
<b>VSWR @ BW</b>	2.0 max.
<b>Amplitude Difference (dB)</b>	2.0 max.
<b>Reel Quantity</b>	4,000
<b>Operating Temperature</b>	-40 to +85°C
<b>Recommended Storage Conditions for Unused product on T&amp;R</b>	+5 ~ +35 °C, Humidity 45~75%RH, 18 months.
<b>Input Power</b>	500mW max. (CW)



Download the gerber files at: <https://www.johansontechnology.com/silabs>

Part Number Explanation			
<b>P/N Suffix</b>	<b>Packing Style</b>	Bulk	Suffix = S eg. 0433BM41A0019S
		T & R	Suffix = E eg. 0433BM41A0019E
	<b>Termination style</b>	Ni/Sn	Suffix = None eg. 0433BM41A0019(E or S)

Mechanical Dimensions		
	In	mm
<b>L</b>	0.126 ± 0.008	3.20 ± 0.20
<b>W</b>	0.098 ± 0.008	2.50 ± 0.20
<b>T</b>	0.059 ± 0.006	1.50 ± 0.15
<b>a1</b>	0.022 ± 0.006	0.55 ± 0.15
<b>a2</b>	0.028 ± 0.008	0.70 ± 0.20
<b>b</b>	0.004 min.	0.1 min.
<b>c</b>	0.012 + 0.008	0.30 + 0.20
<b>g</b>	0.018 + 0.006	0.45 + 0.15
<b>p</b>	0.039 + 0.008	1.00 + 0.20

Unit :mm

Terminal Configuration			
No.	Function	No.	Function
1	GND	5	GND
2	Ant	6	TX
3	GND	7	RXN
4	GND	8	RXP

DC Connection for Pins	
(1)	Pin1 – Pin3 – Pin4 – Pin5
(2)	Pin2 – Pin7 – Pin8

Do you need to download the reference design/layout files? Go to: <https://www.johansontechnology.com/silabs>



4001 Calle Tecate • Camarillo, CA 93012 • TEL 805.389.1166 FAX 805.389.1821

Ver 1.3

2017 Johanson Technology, Inc. All Rights Reserved

[www.johansontechnology.com](http://www.johansontechnology.com)

# "High Frequency Ceramic Solutions"

433 MHz Impedance Matched Balun + LPF Integrated Front-End SMD Passive  
Component for SiLabs Si4455, Si4460, Si4461, Si4463, and Si4464 Chipsets

P/N 0433BM41A0019

Detail Specification: 5/30/2017

Page 2 of 5

## Mounting Considerations

\* Line/Via width should be designed to match 50Ohm characteristic impedance, depending on PCB material and thickness.

Download gerber files at: <https://www.johansontechnology.com/silabs>

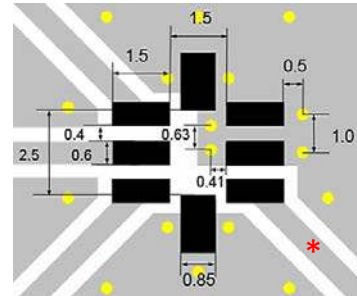
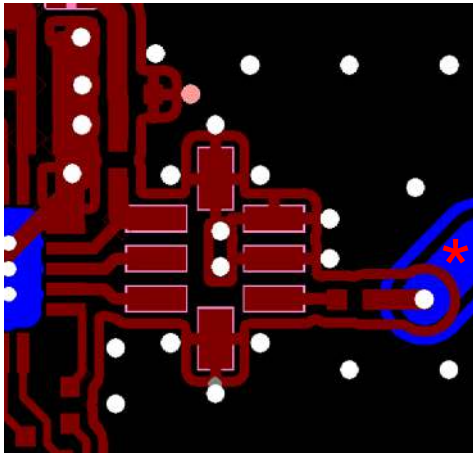

- Solder Resist
- Land
- Through-hole ( $\phi$  0.3)

Do you need the layout/gerber files of the above? Go to: <https://www.johansontechnology.com/silabs> or send us a message at: <https://www.johansontechnology.com/ask-a-question>

## Measuring Diagram

### Tx Mode

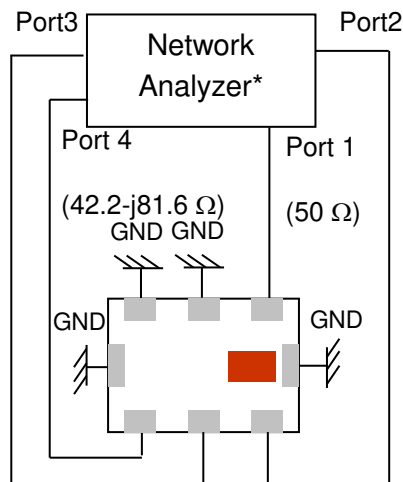

### Rx Mode

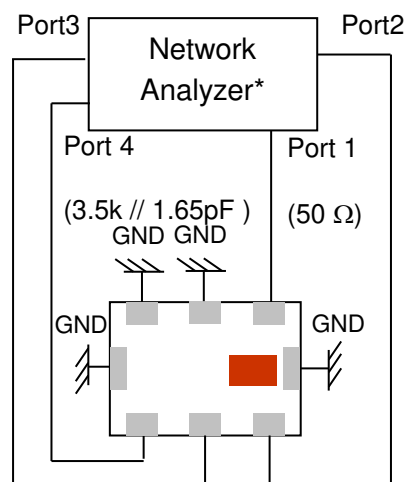

Johanson Technology, Inc. reserves the right to make design changes without notice. Please confirm the specifications and delivery conditions when placing your order. All sales are subject to Johanson Technology, Inc. terms and conditions.



[www.johansontechnology.com](http://www.johansontechnology.com)

4001 Calle Tecate • Camarillo, CA 93012 • TEL 805.389.1166 FAX 805.389.1821

Ver 1.3

2017 Johanson Technology, Inc. All Rights Reserved

# "High Frequency Ceramic Solutions"

433 MHz Impedance Matched Balun + LPF Integrated Front-End SMD Passive Component for SiLabs Si4455, Si4460, Si4461, Si4463, and Si4464 Chipsets

P/N 0433BM41A0019

Detail Specification: 5/30/2017

Page 3 of 5

## Measuring Diagram (cont.)

### Tx Mode:

Port1: Antenna Port  
Port1 Terminate impedance: 50ohm  
Ports 2 and 3: Rx Balanced Port  
Port 2 and 3 Terminate impedance:  
1/2 x (the loading impedance ZIC,RX  
off of Si4455)  
Port4: Tx Port  
Port4 Terminate impedance:  
Complex conjugate to ZIC,TX on of  
Si4455

IL = S41  
RL = S11 / S44

### RXMode:

Port 1: Antenna Port  
Port1 Terminate impedance: 50ohm  
Ports 2 and 3: Rx Balanced Port  
Port 2 and 3 Terminate impedance:  
Complex conjugate to 1/2 x (Balance  
impedance of ZIC,RX on of Si4455)  
Port4: Tx Port  
Port4 Terminate impedance: The loading  
impedance ZIC,TX off of Si4455

IL=Sds21  
RL=Sss11 / Sdd22  
Amp\_balance = dB(S(3,1)/S(2,1))

## Typical Electrical Characteristics (T=25oC)

### TX mode:

#### Insertion and Return Loss

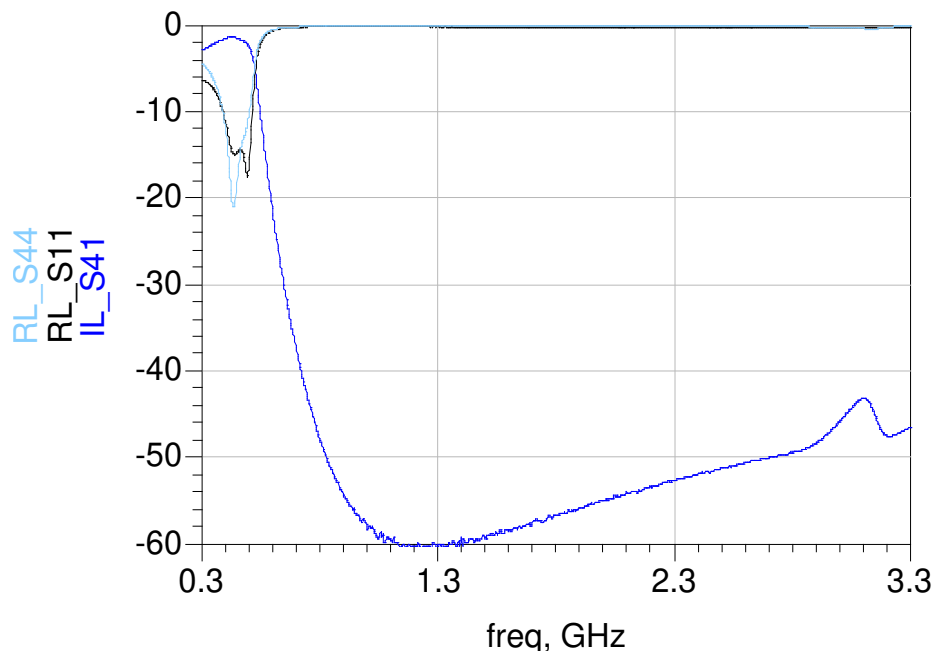

Johanson Technology, Inc. reserves the right to make design changes without notice. Please confirm the specifications and delivery conditions when placing your order. All sales are subject to Johanson Technology, Inc. terms and conditions.



[www.johansontechnology.com](http://www.johansontechnology.com)

4001 Calle Tecate • Camarillo, CA 93012 • TEL 805.389.1166 FAX 805.389.1821

Ver 1.3

2017 Johanson Technology, Inc. All Rights Reserved

# "High Frequency Ceramic Solutions"

433 MHz Impedance Matched Balun + LPF Integrated Front-End SMD Passive Component for SiLabs Si4455, Si4460, Si4461, Si4463, and Si4464 Chipsets

P/N 0433BM41A0019

Detail Specification: 5/30/2017

Page 4 of 5

## Typical Electrical Characteristics (T=25oC)

RX mode:

Insertion and Return Loss

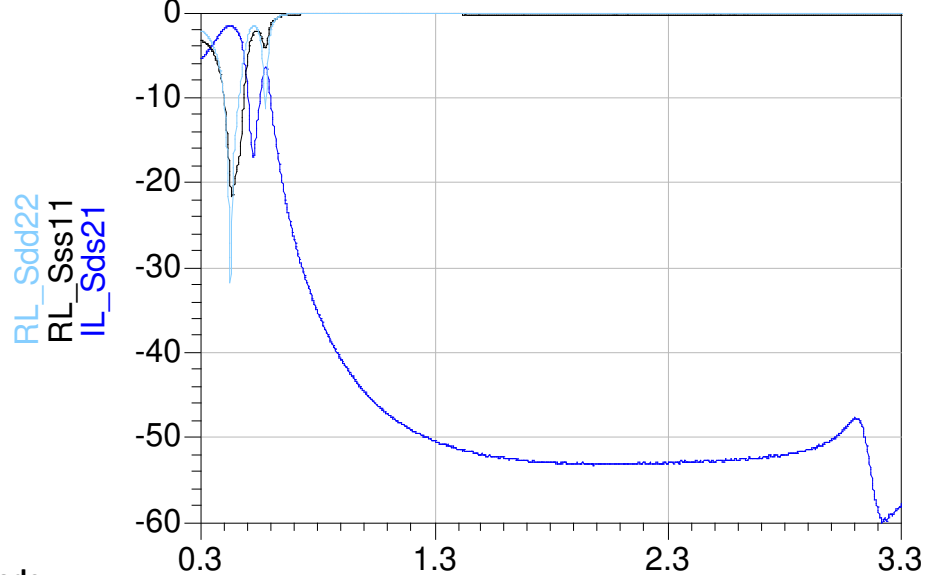

RX mode:

Amplitude and Phase Balance

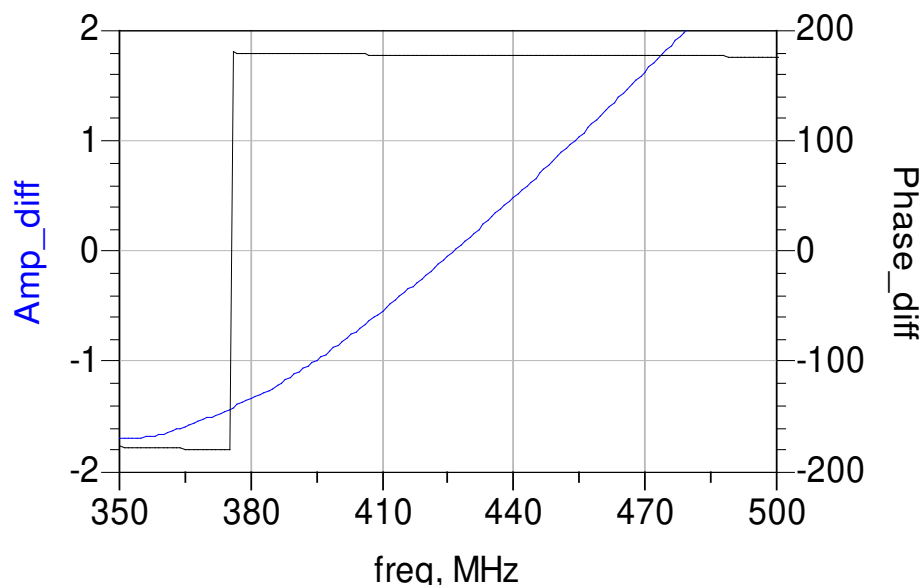

Johanson Technology, Inc. reserves the right to make design changes without notice. Please confirm the specifications and delivery conditions when placing your order. All sales are subject to Johanson Technology, Inc. terms and conditions.



[www.johansontechnology.com](http://www.johansontechnology.com)

4001 Calle Tecate • Camarillo, CA 93012 • TEL 805.389.1166 FAX 805.389.1821

Ver 1.3

2017 Johanson Technology, Inc. All Rights Reserved

# "High Frequency Ceramic Solutions"

433 MHz Impedance Matched Balun + LPF Integrated Front-End SMD Passive  
Component for SiLabs Si4455, Si4460, Si4461, Si4463, and Si4464 Chipsets

P/N 0433BM41A0019

Detail Specification: 5/30/2017

Page 5 of 5

## Application Notes, Layout Files, and more

[www.johansontechnology.com/silabs](http://www.johansontechnology.com/silabs)

## RoHS Compliance

[www.johansontechnology.com/technical-notes/rohs-compliance.html](http://www.johansontechnology.com/technical-notes/rohs-compliance.html)

## Soldering Information

[www.johansontechnology.com/ipcsoldering-profile](http://www.johansontechnology.com/ipcsoldering-profile)

## Antenna layout and tuning techniques

[www.johansontechnology.com/tuning](http://www.johansontechnology.com/tuning)

## Antenna layout review, tuning, and characterization services

[www.johansontechnology.com/ipcantennaservices](http://www.johansontechnology.com/ipcantennaservices)

## MSL Info

[www.johansontechnology.com/technical-notes/msl-rating](http://www.johansontechnology.com/technical-notes/msl-rating)

## Recommended Storage Condition and Max Shelf Life

[www.johansontechnology.com/recommended-storage-conditions](http://www.johansontechnology.com/recommended-storage-conditions)

## Packaging information

[www.johansontechnology.com/tape-reel-packaging](http://www.johansontechnology.com/tape-reel-packaging)

Johanson Technology, Inc. reserves the right to make design changes without notice.

All sales are subject to Johanson Technology, Inc. terms and conditions.



[www.johansontechnology.com](http://www.johansontechnology.com)  
4001 Calle Tecate • Camarillo, CA 93012 • TEL 805.389.1166 FAX 805.389.1821  
Ver 1.3 2017 Johanson Technology, Inc. All Rights Reserved