

Tous droits strictement réservés. Reproduction ou communication a des tiers interdite sous quelque forme que ce soit sans autorisation écrite du propriétaire. Propriete de c FCI. Droits de reproduction FCI.

All rights strictly reserved. Reproduction or issue to third parties in any form whatever is not permitted without written authority from the proprietor. Property of FCI. Copyright FCI.

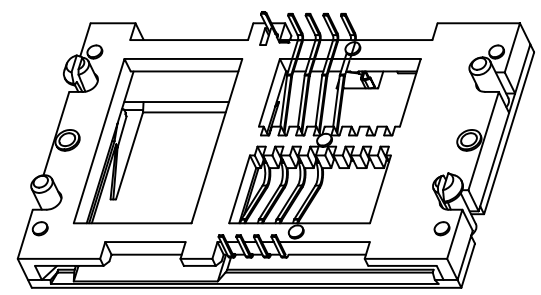

NOTES:

- 1.L04 STANDARD READER LOW PROFILE 6.5mm HEIGHT.
- 2.DETECTOR TYPE:BLADE CONTACTS NORMALLY OPEN.
3. MATERIAL:
CONTACT: PHOSPHOR BRONZE
HOUSING(BASE): UL 94V-0 PC.
COVER: UL 94V-0,PA46.
- 4.PLATING:15u" MINIMUM GOLD IN CONTACT AREA;
120u" MINIMUM TIN-LEAD OR MATTE PURE TIN IN SOLDER TAIL AREA;
50u" MINIMUM NICKEL UNDERPLATE OVER ALL SURFACES.
- 5.IF LEAD FREE P/N, GS-14-920 SHOULD BE APPLIED
- 6.IF LF P/N,THE PRODUCT MEETS EUROPEAN UNION DIRECTIVES AND OTHER COUNTRY REGULATIONS AS DESCRIBED IN GS -22-008.
- 7.THE HOUSING WILL WITHSTAND EXPOSURE TO 260 ° PEAK TEMPERATURE FOR 5 SENCONDS IN A WAVE SOLDER APPLICATION WITH A 1.6mm MINIMUM THICKNESS CIRCUIT BOARD.
8. GENERAL TOLERANCE: 0 mm TO 10 mm: ±0.1 mm
10 mm TO 30 mm: ±0.15 mm
30 mm TO 60 mm: ±0.2 mm
>60 mm: ±0.3 mm
9. FLATNESS CONTROL WITHIN 0.25mm MAX.

10. 52400- X X A LF

- LEAD FREE OPTION
- BLADE CONTACTS NORMALLY OPEN
- 2: CONTACT PLATING 15u" Au OVER NICKEL.
- 3: CONTACT PLATING 30u" Au OVER NICKEL.
- 5: CONTACT PLATING 80u" Au OVER NICKEL.
- NO. OF CONTACTS:
- 1:6 CONTACTS
- 2:8 CONTACTS
- 3:16 CONTACTS

CONFIDENTIAL

mat'l. code				tolerances unless otherwise specified				CUSTOMER COPY		 www.fciconnect.com	
ltr	ecn no	dr	date	linear	.X ±			projection	title		
A	T90345	GT	09/30/99		.XX ±				L04 6.5MM HEIGHT		
B	T04-0253	MW	06/11/04		.XXX ±				NORMALLY OPEN		
C	N05-0092	AILEI	03/25/05	angles	0° ±			 MM	product family		code
D	N05-0203	AILEI	07/12/05	dr	MAGGIE WU	07/05/99	SMART CARD		-		
E	N05-0326	AILEI	11/18/05	enrg	GARY TANG	07/05/99	size		-		
				chr	GARY TANG	07/05/99	scale	A4		sheet	
				appd	JENN TSAO	07/05/99		1.5:1		1 of 2	
sheet index	revision sheet	D	E								
		1	2								

Tous droits strictement reserves. Reproduction ou communication a des tiers interdite sous quelque forme que ce soit sans autorisation écrite du propriétaire. Propriete de c FCI. Droits de reproduction FCI.

All rights strictly reserved. Reproduction or issue to third parties in any form whatever is not permitted without written authority from the proprietor. Property of FCI. Copyright FCI.

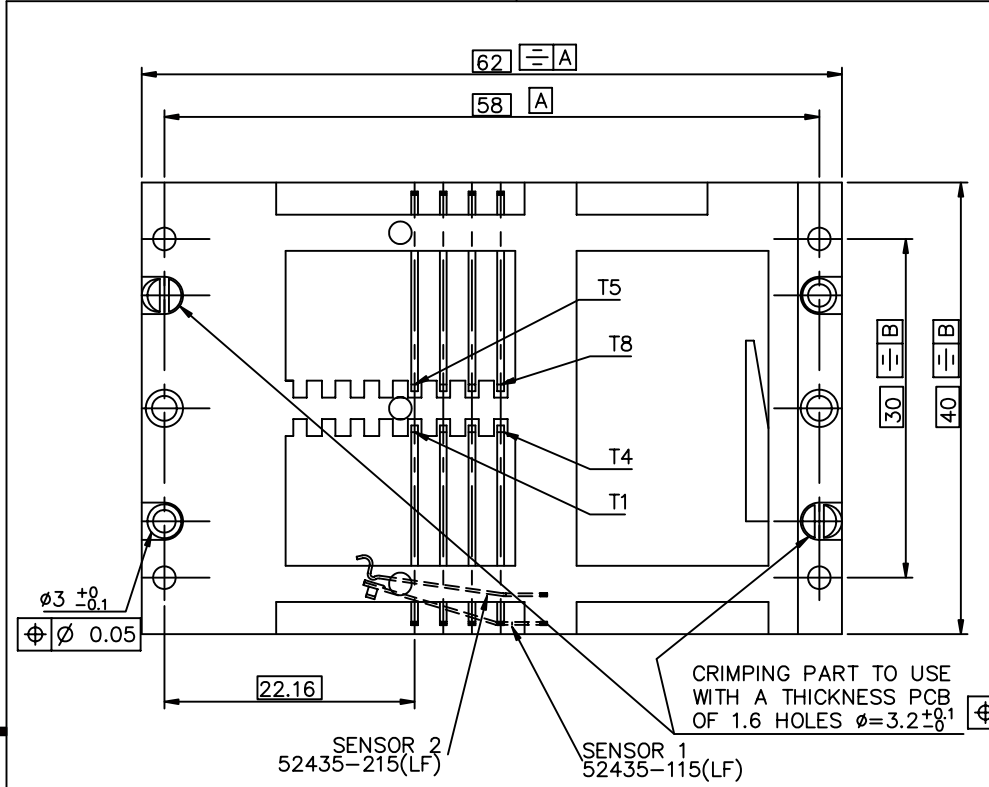

PIN DEFINITION

SMART CARD	TERMINAL	FUNC.
C4	T4	RFU
C3	T3	Clock
C2	T2	Reset
C1	T1	Vcc
SENSOR 1	SENSOR 1	SENSOR
SENSOR 2	SENSOR 2	SENSOR
C5	T5	Gnd
C6	T6	Vpp
C7	T7	I/O
C8	T8	RFU

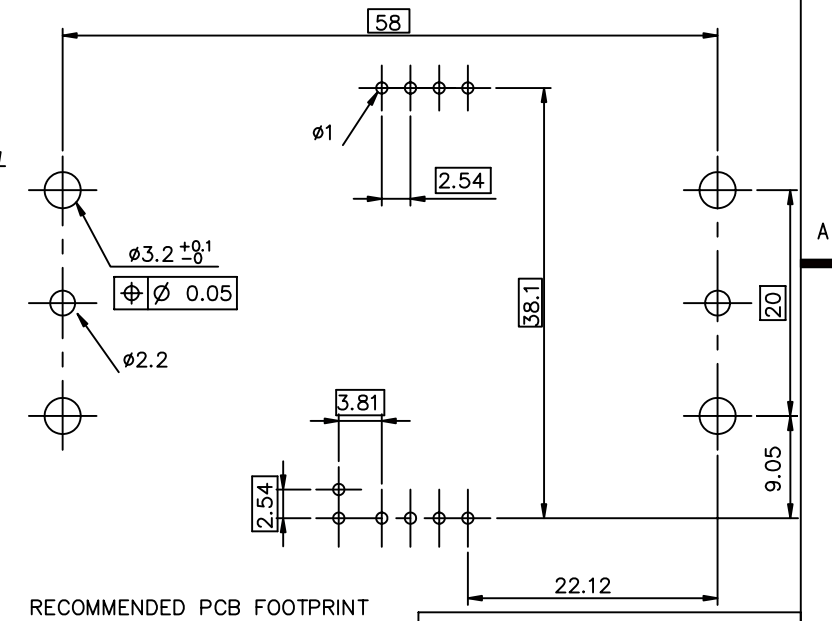

RECOMMENDED PCB FOOTPRINT

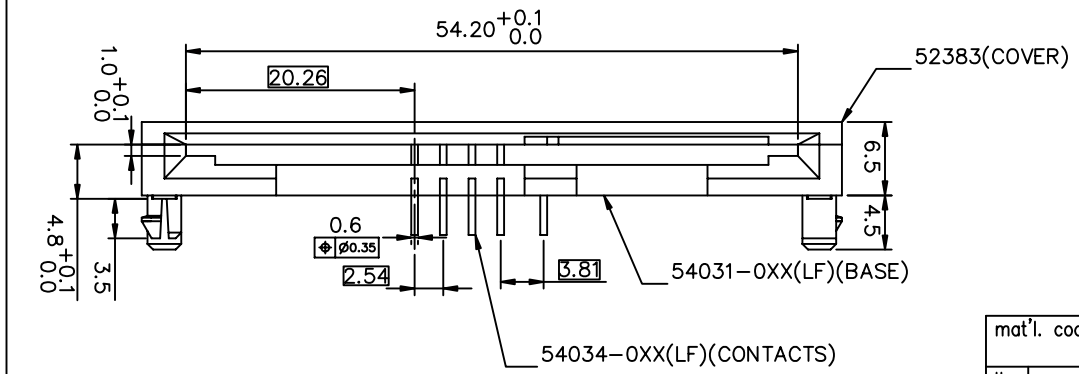

CONFIDENTIAL

mat'l. code		tolerances unless otherwise specified		CUSTOMER COPY		 www.fciconnect.com	
ltr	ecn no	dr	date	linear	.X ±	projection	title L04 6.5MM HEIGHT NORMALLY OPEN
E					.XX ±		
				angles	.XXX ±	MM	product family SMART CARD code - size dwg no
				dr	0° ±	scale	
				enr		1.5:1	
				chr			
				appd			
sheet index	revision sheet						