

## Evaluating the **ADM7154** and **ADM7155** Linear Regulators

### REGULATOR FEATURES

Input voltage range: 2.3 V to 5.5 V

Maximum output current: 600 mA

Low noise

0.9  $\mu\text{V}$  rms total integrated noise from 100 Hz to 100 kHz

1.6  $\mu\text{V}$  rms total integrated noise from 10 Hz to 100 kHz

Initial accuracy:  $\pm 0.5\%$

Fixed 3.3 V (**ADM7154**) and adjustable (**ADM7155**) output versions

8-lead LFCSP and 8-lead SOIC packages

### EVALUATION KIT CONTENTS

**ADM7154CP-3.3EVALZ**, **ADM7154RD-1.8EVALZ**, or **ADM7155CP-02-EVALZ** evaluation board

### ADDITIONAL EQUIPMENT NEEDED

DC power supply

Multimeters for voltage and current measurements

Electronic or resistive loads

### GENERAL DESCRIPTION

The **ADM7154CP-3.3EVALZ**, **ADM7154RD-1.8-EVALZ**, and **ADM7155CP-02-EVALZ** evaluation boards are used to demonstrate the functionality of the **ADM7154** and **ADM7155** linear regulators, respectively.

Simple device measurements, such as line and load regulation, dropout, and ground current, can be demonstrated with just a single voltage source, a voltmeter, an ammeter, and load resistors.

For more details about the linear regulators, refer to the **ADM7154** and **ADM7155** data sheets.

### EVALUATION BOARDS

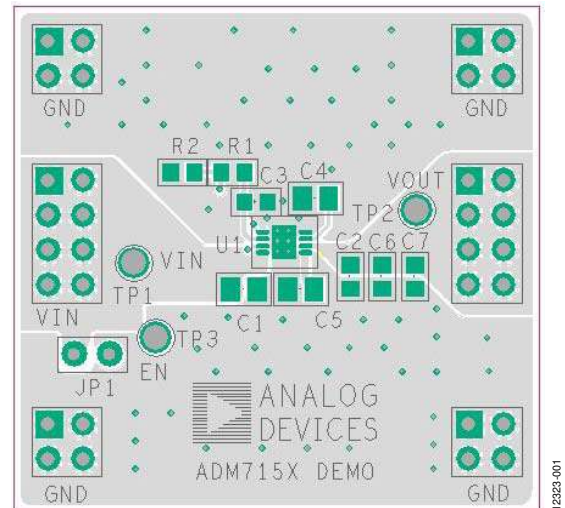

Figure 1. **ADM7154CP-3.3EVALZ** and **ADM7155CP-02-EVALZ** LFCSP Evaluation Board

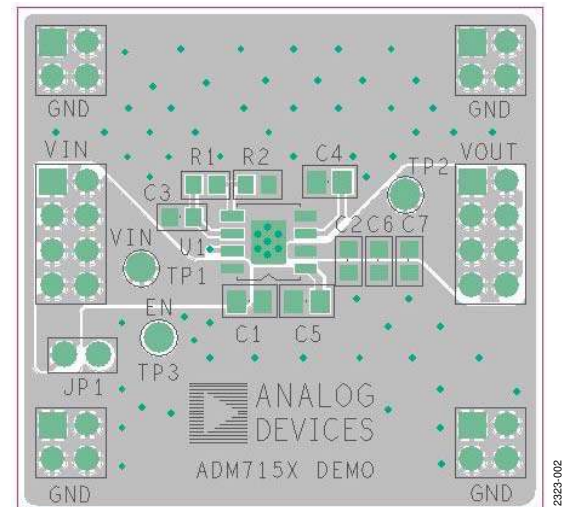

Figure 2. **ADM7154RD-1.8EVALZ** LFCSP Evaluation Board

**TABLE OF CONTENTS**

Regulator Features .....	1	Line Regulation.....	5
Evaluation Kit Contents.....	1	Load Regulation .....	5
Additional Equipment Needed .....	1	Dropout Voltage .....	5
General Description .....	1	Ground Current Measurements .....	6
Evaluation Boards.....	1	Ground Current Consumption .....	7
Revision History .....	2	Schematic.....	8
Evaluation Board Hardware.....	3	Bill of Materials.....	9
Evaluation Board Configurations .....	3		
Output Voltage Measurements .....	4		

**REVISION HISTORY**

**10/14—Revision 0: Initial Version**

## EVALUATION BOARD HARDWARE

### EVALUATION BOARD CONFIGURATIONS

The evaluation boards arrive supplied with different components depending on which version is ordered. Components common to both versions are C1, C2, C3, C4, C5, J1, and J2.

Resistors R1 and R2 are used for the [ADM7155](#) adjustable output option. The output voltage ( $V_{OUT}$ ) is set by

$$V_{OUT} = 1.2 \text{ V} \times (1 + R1/R2)$$

**Table 1. Evaluation Board Hardware Components**

Component	Function	Description
U1 <sup>1</sup>	Linear regulator	<a href="#">ADM7154ARDZ-1.8/ADM7154ACPZ-3.3/ADM7155ACPZ-02</a> linear regulator.
C1	Input capacitor	10 $\mu\text{F}$ input bypass capacitor.
C2	Output capacitor	10 $\mu\text{F}$ output capacitor. Required for stability and transient performance.
C3	$V_{REF}$ capacitor	1 $\mu\text{F}$ $V_{REF}$ bypass capacitor.
C4	BYP capacitor	1 $\mu\text{F}$ bypass capacitor.
C5	$V_{REG}$ capacitor	10 $\mu\text{F}$ $V_{REG}$ bypass capacitor.
C6 and C7	Output capacitor	Optional output capacitors.
R1	Output divider	Sets output voltage with R2 in adjustable option. Short R1 for fixed output voltages.
R2	Output divider	Sets output voltage with R1 in adjustable option.
JP1	Jumper	Jumper. Connects EN to VIN for automatic startup.

<sup>1</sup> Component varies depending on the evaluation board ordered.

## OUTPUT VOLTAGE MEASUREMENTS

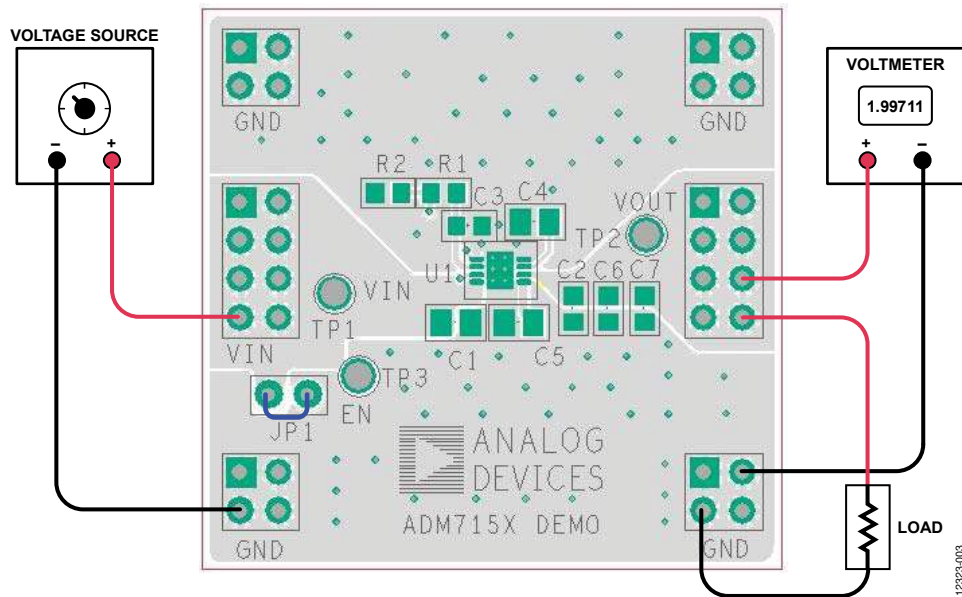

Figure 3. Output Voltage Measurement, LFCSP

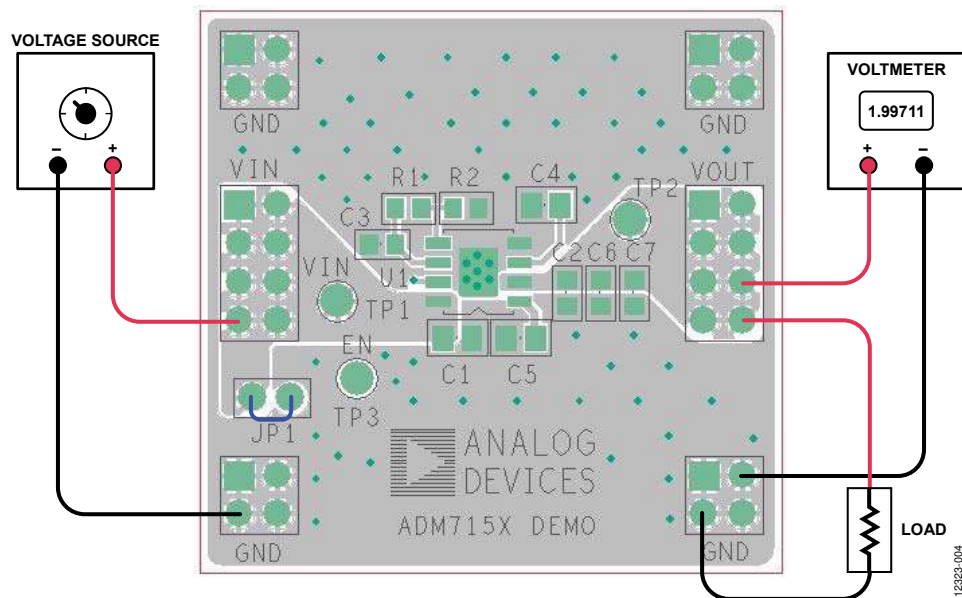

Figure 4. Output Voltage Measurement, SOIC

Figure 3 shows how the evaluation board can be connected to a voltage source and a voltmeter for basic output voltage accuracy measurements. A resistor can be used as the load for the regulator.

Ensure that the resistor has a power rating adequate to handle the power dissipation. Alternatively, an electronic load can also be used in place of a resistor. Ensure that the voltage source can supply enough current for the expected load levels.

Use the following steps to connect to a voltage source and voltmeter:

1. Connect the negative terminal (–) of the voltage source to one of the GND pads on the evaluation board.

2. Connect the positive terminal (+) of the voltage source to the VIN pad of the evaluation board.
3. Connect a load between the VOUT pad and one of the GND pads.
4. Connect the negative terminal (–) of the voltmeter to one of the GND pads.
5. Connect the positive terminal (+) of the voltmeter to the VOUT pad.

The voltage source can then be turned on. If JP1 is inserted, connecting EN to VIN for automatic startup, the regulator powers up.

If the load current is greater than about 200 mA, it is recommended that the user connect the voltmeter as close as possible to the output capacitor to reduce the effects of IR drops.

**LINE REGULATION**

The output of the regulator is monitored and the input is varied for line regulation measurements. For good line regulation, the output must change as little as possible with varying input levels. To ensure that the device is not in dropout during this measurement,  $V_{IN}$  must be varied between  $V_{OUTNOM} + 0.5\text{ V}$  (or 2.3 V, whichever is greater) and  $V_{INMAX}$ . For example, for an ADM7154 with a fixed 3.3 V output,  $V_{IN}$  must be varied between 3.8 V and 5.5 V. This measurement can be repeated under different load conditions. Figure 5 shows the typical line regulation performance of an ADM7154 with a fixed 3.3 V output.

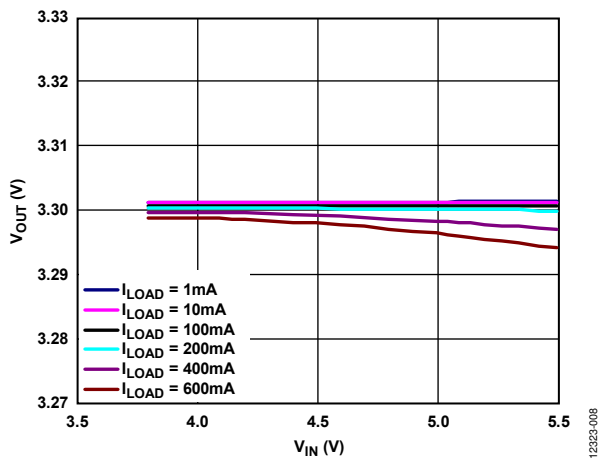

Figure 5. Output Voltage ( $V_{OUT}$ ) vs. Input Voltage ( $V_{IN}$ )

**LOAD REGULATION**

The output of the regulator is monitored and the load is varied for load regulation measurements. For good load regulation, the output must change as little as possible with varying loads. The input voltage must be held constant during this measurement. The load current can be varied from 0 mA to 600 mA. Figure 6 shows the typical load regulation performance of an ADM7154 with a fixed 3.3 V output for an input voltage of 3.8 V.

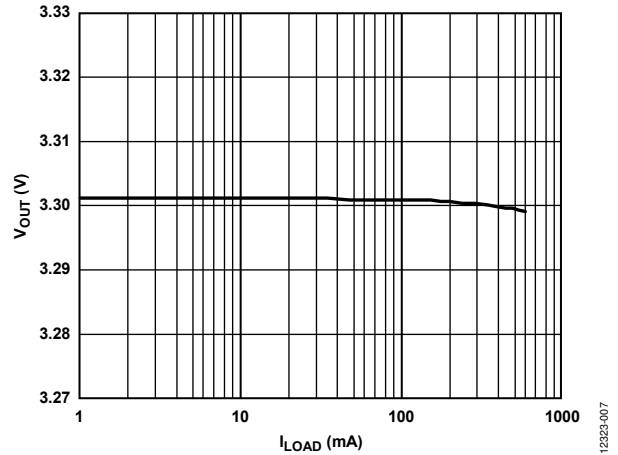

Figure 6. Output Voltage ( $V_{OUT}$ ) vs. Load Current ( $I_{LOAD}$ )

**DROPOUT VOLTAGE**

Measure dropout voltage using the configuration shown in Figure 3 and Figure 4. Dropout voltage is defined as the input to output voltage differential when the input voltage is set to the nominal output voltage. This applies only for output voltages greater than 2.3 V. Dropout voltage increases with larger loads. For more accurate measurements, use a second voltmeter to monitor the input voltage across the input capacitor. The input supply voltage may need adjusting to account for IR drops, especially if large load currents are used. Figure 7 shows a typical curve of dropout voltage measurements vs. load current.

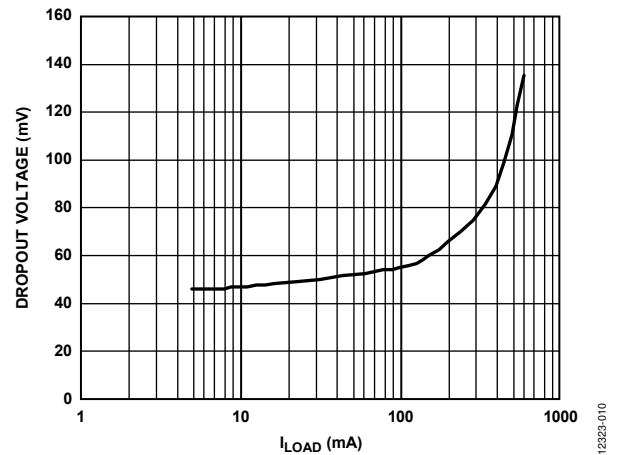
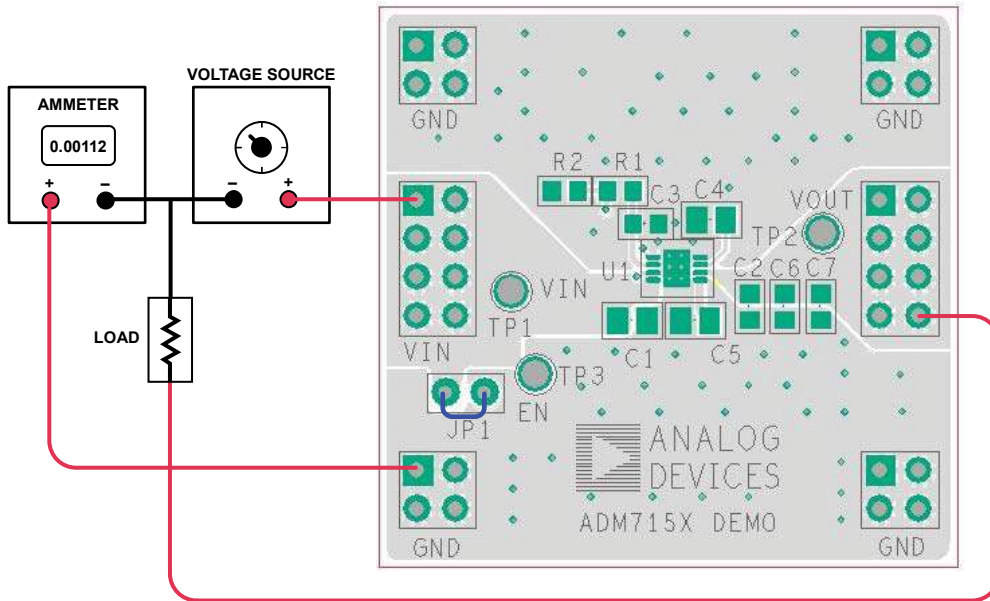

Figure 7. Dropout Voltage vs. Load Current ( $I_{LOAD}$ )

# GROUND CURRENT MEASUREMENTS



12323-005

Figure 8. Ground Current Measurement, LFCSP

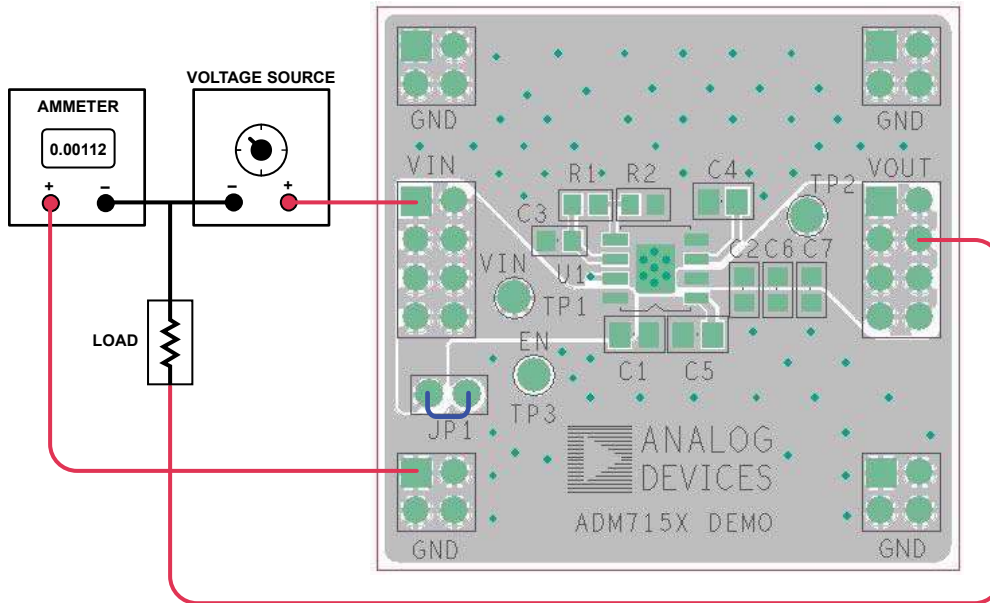

12323-006

Figure 9. Ground Current Measurement, SOIC

Figure 8 and Figure 9 show how the evaluation board is connected to a voltage source and an ammeter for ground current measurements. A resistor can be used as the load for the regulator. Ensure that the resistor has a power rating adequate to handle the expected power dissipation. Alternatively, an electronic load can also be used in place of a resistor. Ensure that the voltage source used can supply enough current for the expected load levels.

Use the following steps to connect to a voltage source and ammeter:

1. Connect the positive terminal (+) of the voltage source to the VIN pad on the evaluation board.
2. Connect the positive terminal (+) of the ammeter to one of the GND pads of the evaluation board.
3. Connect the negative terminal (-) of the ammeter to the negative (-) terminal of the voltage source.
4. Connect a load between the negative (-) terminal of the voltage source and the VOUT pad of the evaluation board.

Then, the voltage source can be turned on. If JP1 is inserted, connecting EN to VIN for automatic startup, the regulator powers up.

## GROUND CURRENT CONSUMPTION

Ground current measurements determine how much current the internal circuits of the regulator are consuming while the circuits perform the regulation function. To be efficient, the regulator needs to consume as little current as possible. Typically, the regulator uses the maximum current when supplying its largest load level (600 mA). Figure 10 shows the typical ground current consumption vs. load current at an input voltage of 3.8 V for an output voltage of 3.3 V.

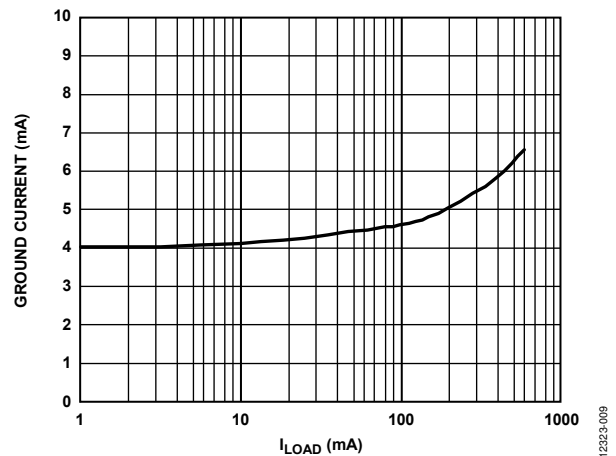

Figure 10. Ground Current vs. Load Current ( $I_{LOAD}$ )

When the device is disabled ( $EN = GND$ ), the ground current drops to less than 2  $\mu A$ .

**SCHEMATIC**

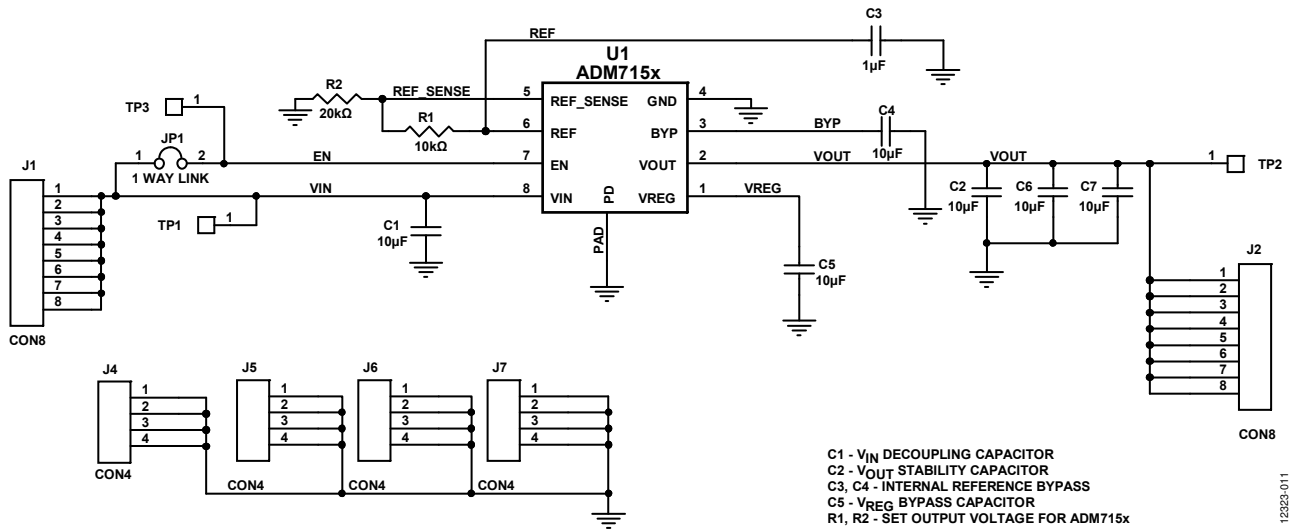

Figure 11. Evaluation Board Schematic

12223-011



## BILL OF MATERIALS

Table 2.

Qty	Reference Designator	Description	Manufacturer	Part Number
1	U1	<a href="#">ADM7154ACPZ-1.8</a> , <a href="#">ADM7154ACPZ-3.3</a> , or <a href="#">ADM7155ACPZ-02</a>	Analog Devices, Inc.	<a href="#">ADM7154ACPZ-1.8</a> , <a href="#">ADM7154ACPZ-3.3</a> , or <a href="#">ADM7155ACPZ-02</a>
3	C1, C2, C5	Capacitor, MLCC, 10 $\mu$ F, 25 V, 0805, X5R	Murata (or equivalent)	GRM216R61E106KA12
2	C3, C4	Capacitor, MLCC, 1 $\mu$ F, 25 V, 0805, X5R	Murata (or equivalent)	GRM216R61E105KA12
1	JP1	Header, single, STR, 2 pins	Sullins Connector Solutions	PEC02SAAN
1	R1, R2	Resistor, 1%, 0603 case	Vishay Dale	CRCW0603xxxxF



### ESD Caution

**ESD (electrostatic discharge) sensitive device.** Charged devices and circuit boards can discharge without detection. Although this product features patented or proprietary protection circuitry, damage may occur on devices subjected to high energy ESD. Therefore, proper ESD precautions should be taken to avoid performance degradation or loss of functionality.

### Legal Terms and Conditions

By using the evaluation board discussed herein (together with any tools, components documentation or support materials, the "Evaluation Board"), you are agreeing to be bound by the terms and conditions set forth below ("Agreement") unless you have purchased the Evaluation Board, in which case the Analog Devices Standard Terms and Conditions of Sale shall govern. Do not use the Evaluation Board until you have read and agreed to the Agreement. Your use of the Evaluation Board shall signify your acceptance of the Agreement. This Agreement is made by and between you ("Customer") and Analog Devices, Inc. ("ADI"), with its principal place of business at One Technology Way, Norwood, MA 02062, USA. Subject to the terms and conditions of the Agreement, ADI hereby grants to Customer a free, limited, personal, temporary, non-exclusive, non-sublicensable, non-transferable license to use the Evaluation Board FOR EVALUATION PURPOSES ONLY. Customer understands and agrees that the Evaluation Board is provided for the sole and exclusive purpose referenced above, and agrees not to use the Evaluation Board for any other purpose. Furthermore, the license granted is expressly made subject to the following additional limitations: Customer shall not (i) rent, lease, display, sell, transfer, assign, sublicense, or distribute the Evaluation Board; and (ii) permit any Third Party to access the Evaluation Board. As used herein, the term "Third Party" includes any entity other than ADI, Customer, their employees, affiliates and in-house consultants. The Evaluation Board is NOT sold to Customer; all rights not expressly granted herein, including ownership of the Evaluation Board, are reserved by ADI. CONFIDENTIALITY. This Agreement and the Evaluation Board shall all be considered the confidential and proprietary information of ADI. Customer may not disclose or transfer any portion of the Evaluation Board to any other party for any reason. Upon discontinuation of use of the Evaluation Board or termination of this Agreement, Customer agrees to promptly return the Evaluation Board to ADI. ADDITIONAL RESTRICTIONS. Customer may not disassemble, decompile or reverse engineer chips on the Evaluation Board. Customer shall inform ADI of any occurred damages or any modifications or alterations it makes to the Evaluation Board, including but not limited to soldering or any other activity that affects the material content of the Evaluation Board. Modifications to the Evaluation Board must comply with applicable law, including but not limited to the RoHS Directive. TERMINATION. ADI may terminate this Agreement at any time upon giving written notice to Customer. Customer agrees to return to ADI the Evaluation Board at that time. LIMITATION OF LIABILITY. THE EVALUATION BOARD PROVIDED HEREUNDER IS PROVIDED "AS IS" AND ADI MAKES NO WARRANTIES OR REPRESENTATIONS OF ANY KIND WITH RESPECT TO IT. ADI SPECIFICALLY DISCLAIMS ANY REPRESENTATIONS, ENDORSEMENTS, GUARANTEES, OR WARRANTIES, EXPRESS OR IMPLIED, RELATED TO THE EVALUATION BOARD INCLUDING, BUT NOT LIMITED TO, THE IMPLIED WARRANTY OF MERCHANTABILITY, TITLE, FITNESS FOR A PARTICULAR PURPOSE OR NON-INFRINGEMENT OF INTELLECTUAL PROPERTY RIGHTS. IN NO EVENT WILL ADI AND ITS LICENSORS BE LIABLE FOR ANY INCIDENTAL, SPECIAL, INDIRECT, OR CONSEQUENTIAL DAMAGES RESULTING FROM CUSTOMER'S POSSESSION OR USE OF THE EVALUATION BOARD, INCLUDING BUT NOT LIMITED TO LOST PROFITS, DELAY COSTS, LABOR COSTS OR LOSS OF GOODWILL. ADI'S TOTAL LIABILITY FROM ANY AND ALL CAUSES SHALL BE LIMITED TO THE AMOUNT OF ONE HUNDRED US DOLLARS (\$100.00). EXPORT. Customer agrees that it will not directly or indirectly export the Evaluation Board to another country, and that it will comply with all applicable United States federal laws and regulations relating to exports. GOVERNING LAW. This Agreement shall be governed by and construed in accordance with the substantive laws of the Commonwealth of Massachusetts (excluding conflict of law rules). Any legal action regarding this Agreement will be heard in the state or federal courts having jurisdiction in Suffolk County, Massachusetts, and Customer hereby submits to the personal jurisdiction and venue of such courts. The United Nations Convention on Contracts for the International Sale of Goods shall not apply to this Agreement and is expressly disclaimed.

©2014 Analog Devices, Inc. All rights reserved. Trademarks and registered trademarks are the property of their respective owners.  
UG12323-0-10/14(10)



www.analog.com