



# 54170/DM74170

## 4 x 4 Register File

### with Open-Collector Outputs

#### General Description

The '170 contains 16 high speed, low power, transparent D-type latches arranged as four words of four bits each, to function as a 4 x 4 register file. Separate read and write inputs, both address and enable, allow simultaneous read and write operation. Open-collector outputs make it possible to connect up to 128 outputs in a wired-AND configuration to increase the word capacity up to 512 words. Any number of these devices can be operated in parallel to generate an n-bit length.

#### Connection Diagram

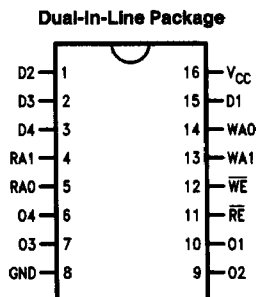

TL/F/9783-1

Order Number 54170DMQB, 54170FMQB or DM74170N  
See NS Package Number J16A, N16E and W16A

#### Logic Symbol

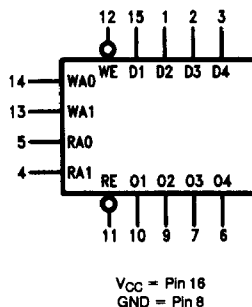

TL/F/9783-2

| Pin Names | Description                     |
|-----------|---------------------------------|
| D1-D4     | Data Inputs                     |
| WAO, WA1  | Write Address Inputs            |
| WE        | Write Enable Input (Active LOW) |
| RA0-RA1   | Read Address Inputs             |
| RE        | Read Enable Input (Active LOW)  |
| O1-O4     | Data Outputs                    |

## Absolute Maximum Ratings

If Military/Aerospace specified devices are required, please contact the National Semiconductor Sales Office/Distributors for availability and specifications.

|                                      |                 |
|--------------------------------------|-----------------|
| Supply Voltage                       | 7V              |
| Input Voltage                        | 5.5V            |
| Operating Free Air Temperature Range |                 |
| 54                                   | -55°C to +125°C |
| DM74                                 | 0°C to +70°C    |
| Storage Temperature Range            | -65°C to +150°C |

Note: The "Absolute Maximum Ratings" are those values beyond which the safety of the device cannot be guaranteed. The device should not be operated at these limits. The parametric values defined in the "Electrical Characteristics" table are not guaranteed at the absolute maximum ratings. The "Recommended Operating Conditions" table will define the conditions for actual device operation.

## Recommended Operating Conditions

| Symbol             | Parameter  | 54170 |     |     | DM74170 |     |      | Units |
|--------------------|--|-------|-----|-----|---------|-----|------|-------|
|                    |  | Min   | Nom | Max | Min     | Nom | Max  |       |
| V <sub>CC</sub>    | Supply Voltage   | 4.5   | 5   | 5.5 | 4.75    | 5   | 5.25 | V     |
| V <sub>IH</sub>    | High Level Input Voltage   | 2     |     |     | 2       |     |      | V     |
| V <sub>IL</sub>    | Low Level Input Voltage  |       |     | 0.8 |         |     | 0.8  | V     |
| V <sub>OH</sub>    | High Level Output Voltage  |       |     | 5.5 |         |     |      | V     |
| I <sub>OL</sub>    | Low Level Output Current   |       |     | 16  |         |     | 16   | mA    |
| T <sub>A</sub>     | Free Air Operating Temperature                                       | -55   |     | 125 | 0       |     | 70   | °C    |
| t <sub>s</sub>     | Setup Time HIGH or LOW<br>D <sub>n</sub> to Rising $\overline{WE}$   | 10    |     |     | 10      |     |      | ns    |
| t <sub>h</sub>     | Hold Time HIGH or LOW<br>D <sub>n</sub> to Rising $\overline{WE}$    | 15    |     |     | 15      |     |      | ns    |
| t <sub>s</sub>     | Setup Time HIGH or LOW<br>WA <sub>n</sub> to Falling $\overline{WE}$ | 15    |     |     | 15      |     |      | ns    |
| t <sub>h</sub>     | Hold Time HIGH or LOW<br>WA <sub>n</sub> to Rising $\overline{WE}$   | 5.0   |     |     | 5.0     |     |      | ns    |
| t <sub>w</sub> (L) | $\overline{WE}$ or $\overline{RE}$ Pulse Width LOW                   | 25    |     |     | 25      |     |      | ns    |

## Electrical Characteristics

Over recommended operating free air temperature range (unless otherwise noted)

| Symbol          | Parameter                            | Conditions   | Min  | Typ<br>(Note 1) | Max  | Units |
|-----------------|--------------------------------------|--|------|-----------------|------|-------|
| V <sub>I</sub>  | Input Clamp Voltage                  | V <sub>CC</sub> = Min, I <sub>I</sub> = -12 mA   |      |                 | -1.5 | V     |
| I <sub>OH</sub> | High Level Output Current            | V <sub>CC</sub> = Min, V <sub>OH</sub> = Max<br>V <sub>IL</sub> = Max                                    |      |                 | 30   | μA    |
| V <sub>OL</sub> | Low Level Output Voltage             | V <sub>CC</sub> = Min, I <sub>OL</sub> = Max<br>V <sub>IH</sub> = Min                                    |      | 0.2             | 0.4  | V     |
| I <sub>I</sub>  | Input Current @ Max<br>Input Voltage | V <sub>CC</sub> = Max, V <sub>I</sub> = 5.5V   |      |                 | 1    | mA    |
| I <sub>IH</sub> | High Level Input Current             | V <sub>CC</sub> = Max, V <sub>I</sub> = 2.4V   |      |                 | 40   | μA    |
| I <sub>IL</sub> | Low Level Input Current              | V <sub>CC</sub> = Max, V <sub>I</sub> = 0.4V   |      |                 | -1.6 | mA    |
| I <sub>CC</sub> | Supply Current                       | V <sub>CC</sub> = Max, RA <sub>n</sub> = 0V<br>D <sub>n</sub> , $\overline{WE}$ , $\overline{RE}$ = 4.5V |      |                 |      | mA    |
|                 |                                      |  | 54   |                 | 140  |       |
|                 |                                      |  | DM74 |                 | 150  |       |

Note 1: All typicals are at V<sub>CC</sub> = 5V, T<sub>A</sub> = 25°C.

## Switching Characteristics

$V_{CC} = +5.0V$ ,  $T_A = +25^\circ C$  (See Section 2 for waveforms and load configurations)

| Symbol                 | Parameter  | 54/DM74                                   |          | Units |
|------------------------|--|---|----------|-------|
|                        |  | $C_L = 15\text{ pF}$<br>$R_L = 400\Omega$ |          |       |
|                        |  | Min                                       | Max      |       |
| $t_{PLH}$<br>$t_{PHL}$ | Propagation Delay*<br>RA <sub>0</sub> or RA <sub>1</sub> to O <sub>n</sub> |   | 35<br>40 | ns    |
| $t_{PLH}$<br>$t_{PHL}$ | Propagation Delay<br>$\overline{RE}$ to O <sub>n</sub>                     |   | 15<br>30 | ns    |
| $t_{PLH}$<br>$t_{PHL}$ | Propagation Delay<br>$\overline{WE}$ to O <sub>n</sub>                     |   | 40<br>45 | ns    |
| $t_{PLH}$<br>$t_{PHL}$ | Propagation Delay<br>D <sub>n</sub> to O <sub>n</sub>                      |   | 30<br>45 | ns    |

\*Measured at least 25 ns after entry of new data at selected location.

## Timing Waveforms

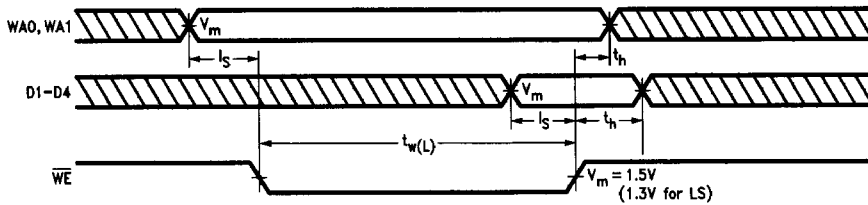

TL/F/9783-4

**Logic Diagram**

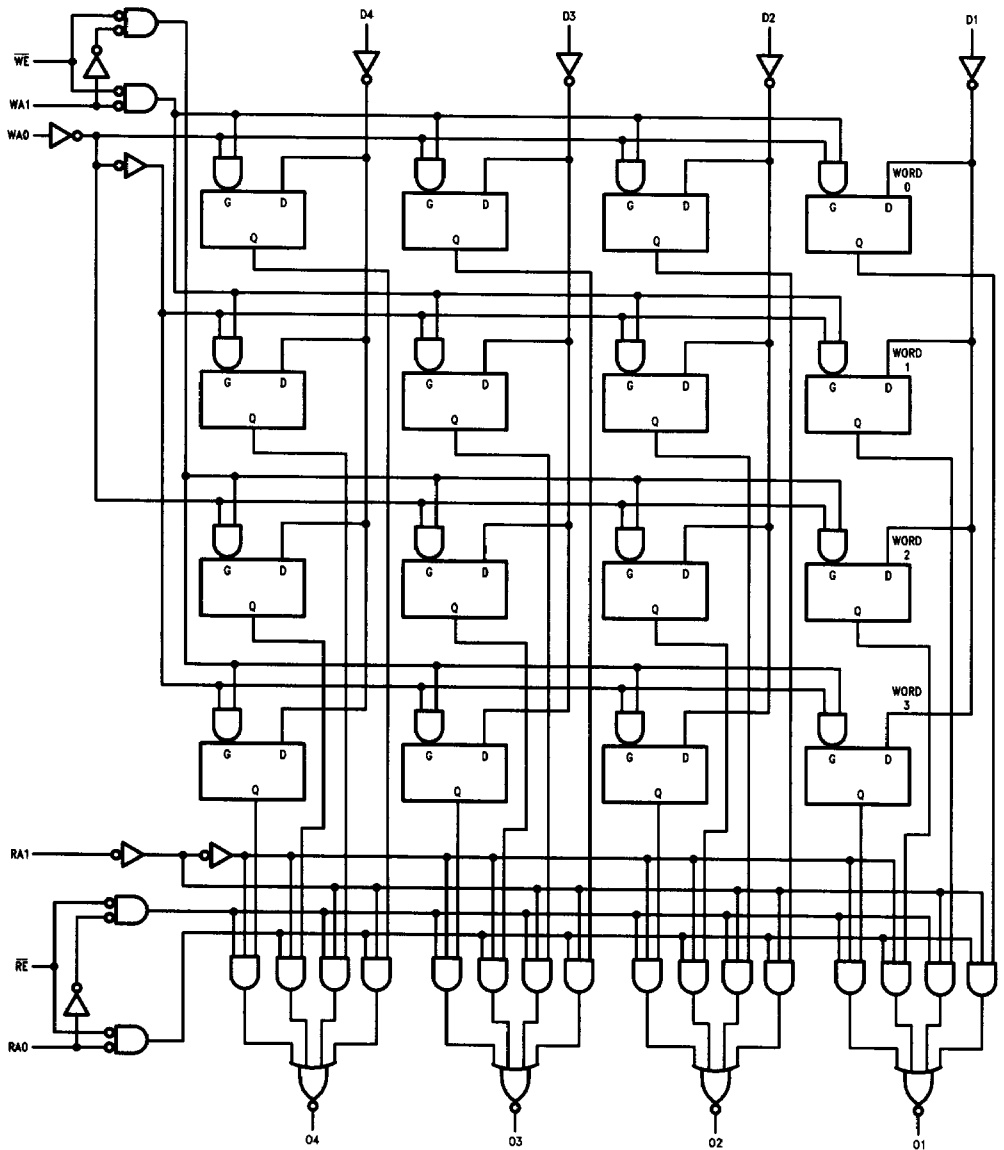

TL/F/9783-3

**Write Function Table**

| Write Inputs |                 |                 | D Inputs To |
|--------------|-----------------|-----------------|-------------|
| WE           | WA <sub>1</sub> | WA <sub>0</sub> |             |
| L            | L               | L               | Word 0      |
| L            | L               | H               | Word 1      |
| L            | H               | L               | Word 2      |
| L            | H               | H               | Word 3      |
| H            | X               | X               | None (Hold) |

**Read Function Table**

| Read Inputs |                 |                 | Outputs From  |
|-------------|-----------------|-----------------|---------------|
| RE          | RA <sub>1</sub> | RA <sub>0</sub> |               |
| L           | L               | L               | Word 0        |
| L           | L               | H               | Word 1        |
| L           | H               | L               | Word 2        |
| L           | H               | H               | Word 3        |
| H           | X               | X               | None (HIGH Z) |

H = HIGH Voltage Level

L = LOW Voltage Level

X = Immaterial