

TVS Diodes

Transient Voltage Suppressor Diodes

ESD105-B1-02 Series

Low Capacitance & Low Clamping Bi-directional ESD / Transient Protection Diodes

ESD105-B1-02ELS
ESD105-B1-02EL

Data Sheet

Revision 1.0, 2013-12-12
Final

Revision History: Rev. 04, 2013-09-24

Page or Item	Subjects (major changes since previous revision)
Revision 1.0, 2013-12-12	
All	Status change to Final

Trademarks of Infineon Technologies AG

AURIX™, BlueMoon™, COMNEON™, C166™, CROSSAVE™, CanPAK™, CIPOS™, CoolMOS™, CoolSET™, CORECONTROL™, DAVE™, EasyPIM™, EconoBRIDGE™, EconoDUAL™, EconoPACK™, EconoPIM™, EiceDRIVER™, EUPEC™, FCOS™, HITFET™, HybridPACK™, ISOFACE™, I²RF™, IsoPACK™, MIPAQ™, ModSTACK™, my-d™, NovalithIC™, OmniTune™, OptiMOS™, ORIGA™, PROFET™, PRO-SIL™, PRIMARION™, PrimePACK™, RASIC™, ReverSave™, SatRIC™, SIEGET™, SINDRION™, SMARTi™, SmartLEWIS™, TEMPFET™, thinQ!™, TriCore™, TRENCHSTOP™, X-GOLD™, XMM™, X-PMU™, XPOSYS™.

Other Trademarks

Advance Design System™ (ADS) of Agilent Technologies, AMBA™, ARM™, MULTI-ICE™, PRIMECELL™, REALVIEW™, THUMB™ of ARM Limited, UK. AUTOSAR™ is licensed by AUTOSAR development partnership. Bluetooth™ of Bluetooth SIG Inc. CAT-iq™ of DECT Forum. COLOSSUS™, FirstGPS™ of Trimble Navigation Ltd. EMV™ of EMVCo, LLC (Visa Holdings Inc.). EPCOS™ of Epcos AG. FLEXGO™ of Microsoft Corporation. FlexRay™ is licensed by FlexRay Consortium. HYPERTERMINAL™ of Hilgraeve Incorporated. IEC™ of Commission Electrotechnique Internationale. IrDA™ of Infrared Data Association Corporation. ISO™ of INTERNATIONAL ORGANIZATION FOR STANDARDIZATION. MATLAB™ of MathWorks, Inc. MAXIM™ of Maxim Integrated Products, Inc. MICROTEC™, NUCLEUS™ of Mentor Graphics Corporation. Mifare™ of NXP. MIPI™ of MIPI Alliance, Inc. MIPS™ of MIPS Technologies, Inc., USA. muRata™ of MURATA MANUFACTURING CO., MICROWAVE OFFICE™ (MWO) of Applied Wave Research Inc., OmniVision™ of OmniVision Technologies, Inc. Openwave™ Openwave Systems Inc. RED HAT™ Red Hat, Inc. RFMD™ RF Micro Devices, Inc. SIRIUS™ of Sirius Sattelite Radio Inc. SOLARIS™ of Sun Microsystems, Inc. SPANSION™ of Spansion LLC Ltd. Symbian™ of Symbian Software Limited. TAIYO YUDEN™ of Taiyo Yuden Co. TEAKLITE™ of CEVA, Inc. TEKTRONIX™ of Tektronix Inc. TOKO™ of TOKO KABUSHIKI KAISHA TA. UNIX™ of X/Open Company Limited. VERILOG™, PALLADIUM™ of Cadence Design Systems, Inc. VLYNQ™ of Texas Instruments Incorporated. VXWORKS™, WIND RIVER™ of WIND RIVER SYSTEMS, INC. ZETEX™ of Diodes Zetex Limited.

Last Trademarks Update 2010-06-09

1 Low Capacitance & Low Clamping Bi-directional ESD / Transient Protection Diodes

1.1 Features

- ESD / Transient protection of signal lines exceeding standard:
 - IEC61000-4-2 (ESD): ± 30 kV air / ± 25 kV contact discharge
 - IEC61000-4-4 (EFT): ± 50 A (5/50 ns)
 - IEC61000-4-5 (Surge): ± 5 A (8/20 μ s)
- One-line diode with ultra-small form factor down to 0.62 x 0.32 x 0.31 mm² (0201) package size
- Bi-directional, symmetrical working voltage up to: $V_{RWM} = \pm 5.5$ V
- Low capacitance $C_L = 0.3$ pF (typical)
- Very low clamping voltage, low dynamic resistance: $R_{DYN} = 0.36$ Ω (typ.)
- Pb-free package (RoHS compliant) and halogen free package



1.2 Application Examples

- USB 3.0, 10/100/1000 Ethernet, Firewire, DVI, HDMI, S-ATA, Display Ports
- Mobile HDMI Link, MDDI, MIPI, SWP, NFC

1.3 Product Description

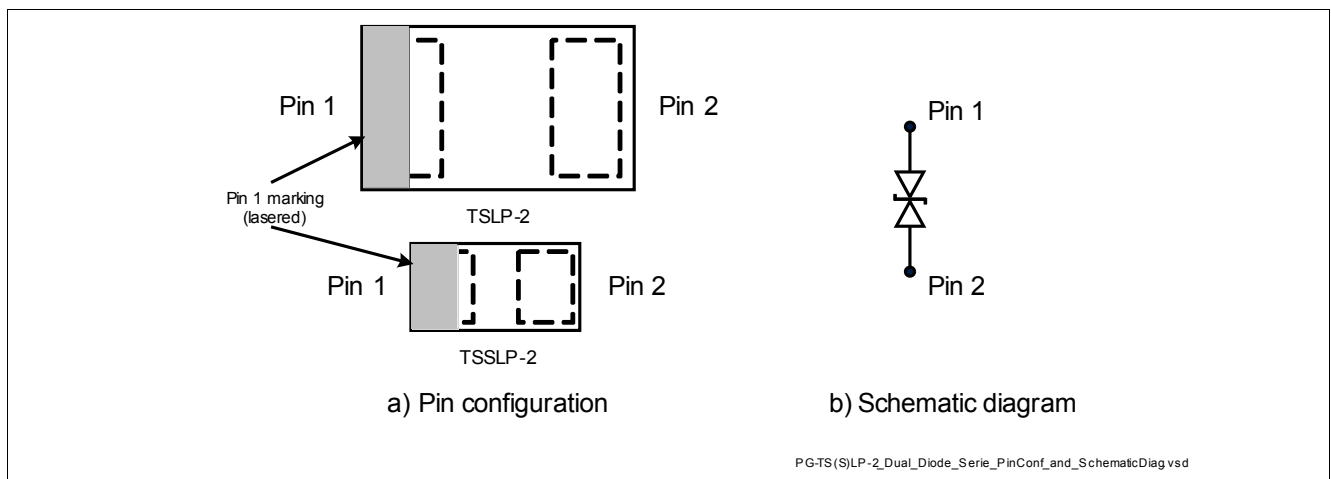

Figure 1 Pin configuration and Schematic diagram

Table 1 Ordering Information

Type	Package	Configuration	Marking code
ESD105-B1-02ELS	TSSLP-2-4	1 line, bi-directional	<u>N</u>
ESD105-B1-02EL	TSLP-2-20	1 line, bi-directional	N

2 Characteristics

Table 2 Maximum Ratings at $T_A = 25\text{ }^\circ\text{C}$, unless otherwise specified ¹⁾

Parameter	Symbol	Values			Unit
		Min.	Typ.	Max.	
ESD ²⁾ air discharge contact discharge	V_{ESD}	–	–	30 25	kV
Peak pulse current ($t_p = 8 / 20\ \mu\text{s}$) ³⁾	I_{PP}	–	–	5	A
Peak pulse power ³⁾ $t_p = 8 / 20\ \mu\text{s}$	P_{PK}	–	–	70	W
Operating temperature	T_{OP}	-55	–	125	$^\circ\text{C}$
Storage temperature	T_{stg}	-65	–	150	$^\circ\text{C}$

- 1) Device is electrically symmetrical
- 2) V_{ESD} according to IEC61000-4-2
- 3) I_{PP} according to IEC61000-4-5

Attention: Stresses above the max. values listed here may cause permanent damage to the device. Exposure to absolute maximum rating conditions for extended periods may affect device reliability. Maximum ratings are absolute ratings; exceeding only one of these values may cause irreversible damage to the integrated circuit.

2.1 Electrical Characteristics at $T_A = 25\text{ }^\circ\text{C}$, unless otherwise specified

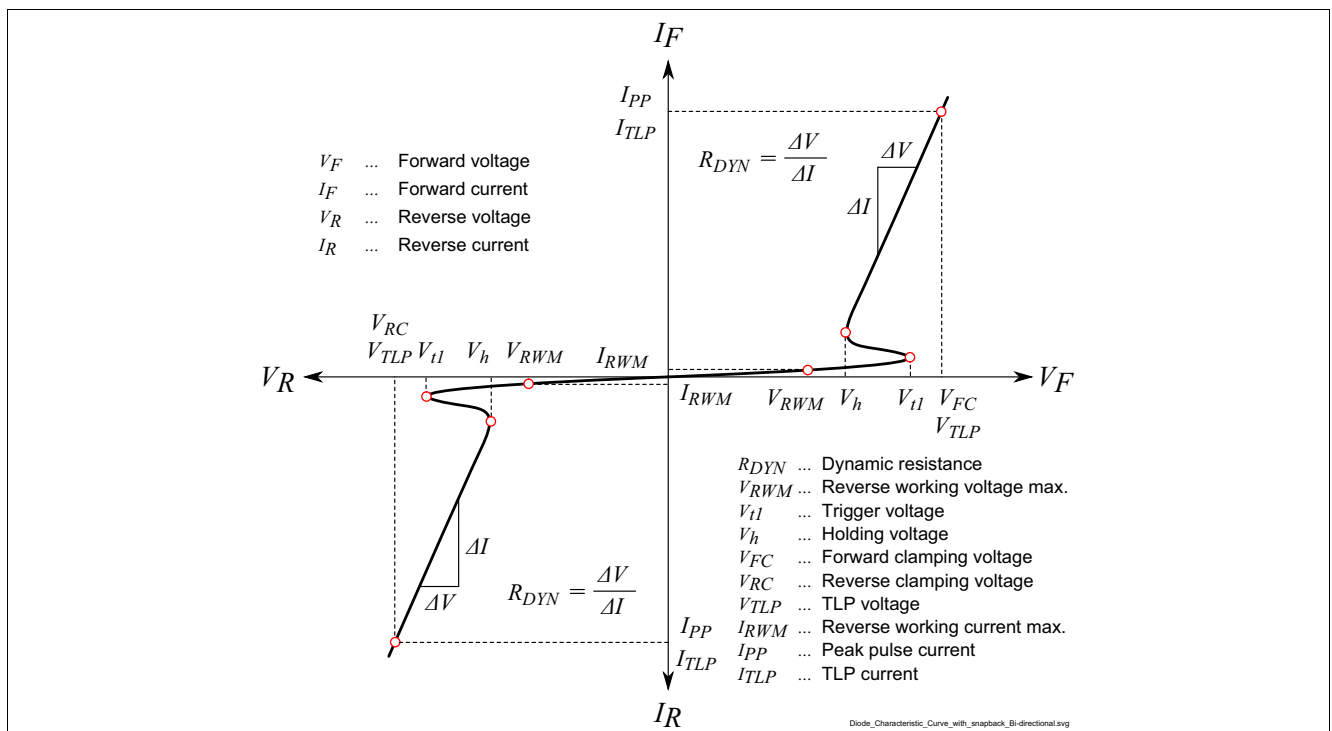

Figure 2 Definitions of electrical characteristics

Table 3 DC Characteristics at $T_A = 25\text{ }^\circ\text{C}$, unless otherwise specified ¹⁾

Parameter	Symbol	Values			Unit	Note / Test Condition
		Min.	Typ.	Max.		
Reverse working voltage	V_{RWM}	–	–	5.5	V	
Reverse current	I_R	–	<1	20	nA	$V_R = 5.5\text{ V}$
Trigger voltage	V_{t1}	6.1	–	–	V	
Holding voltage	V_h	6.1	8	–	V	$I_R = 1\text{ mA}$

1) Device is electrically symmetrical

Table 4 AC Characteristics at $T_A = 25\text{ }^\circ\text{C}$, unless otherwise specified

Parameter	Symbol	Values			Unit	Note / Test Condition
		Min.	Typ.	Max.		
Line capacitance	C_L	–	0.3	0.45	pF	$V_R = 0\text{ V}, f = 1\text{ MHz}$
		–	0.3	0.45		$V_R = 0\text{ V}, f = 1\text{ GHz}$

Table 5 ESD and Surge Characteristics at $T_A = 25\text{ }^\circ\text{C}$, unless otherwise specified ¹⁾

Parameter	Symbol	Values			Unit	Note / Test Condition
		Min.	Typ.	Max.		
Clamping voltage ²⁾	V_{CL}	–	13	16	V	$I_{TLP} = 16\text{ A}, t_p = 100\text{ ns}$
		–	19	22		$I_{TLP} = 30\text{ A}, t_p = 100\text{ ns}$
Clamping voltage ³⁾		–	8.5	11.5		$I_{PP} = 2\text{ A}, t_p = 8/20\text{ }\mu\text{s}$
		–	11	14		$I_{PP} = 5\text{ A}, t_p = 8/20\text{ }\mu\text{s}$
Dynamic resistance ²⁾	R_{DYN}	–	0.36	0.45	Ω	$t_p = 100\text{ ns}$

1) Device is electrically symmetrical

2) Please refer to Application Note AN210 [1]. TLP parameter: $Z_0 = 50\text{ }\Omega$, $t_p = 100\text{ ns}$, $t_r = 300\text{ ps}$, averaging window: $t_1 = 30\text{ ns}$ to $t_2 = 60\text{ ns}$, extraction of dynamic resistance using least squares fit of TLP characteristics between $I_{TLP1} = 10\text{ A}$ and $I_{TLP2} = 50\text{ A}$.

3) I_{PP} according to IEC61000-4-5 ($t_p = 8/20\text{ }\mu\text{s}$)

Typical Characteristics at $T_A = 25\text{ °C}$, unless otherwise specified

3 Typical Characteristics at $T_A = 25\text{ °C}$, unless otherwise specified

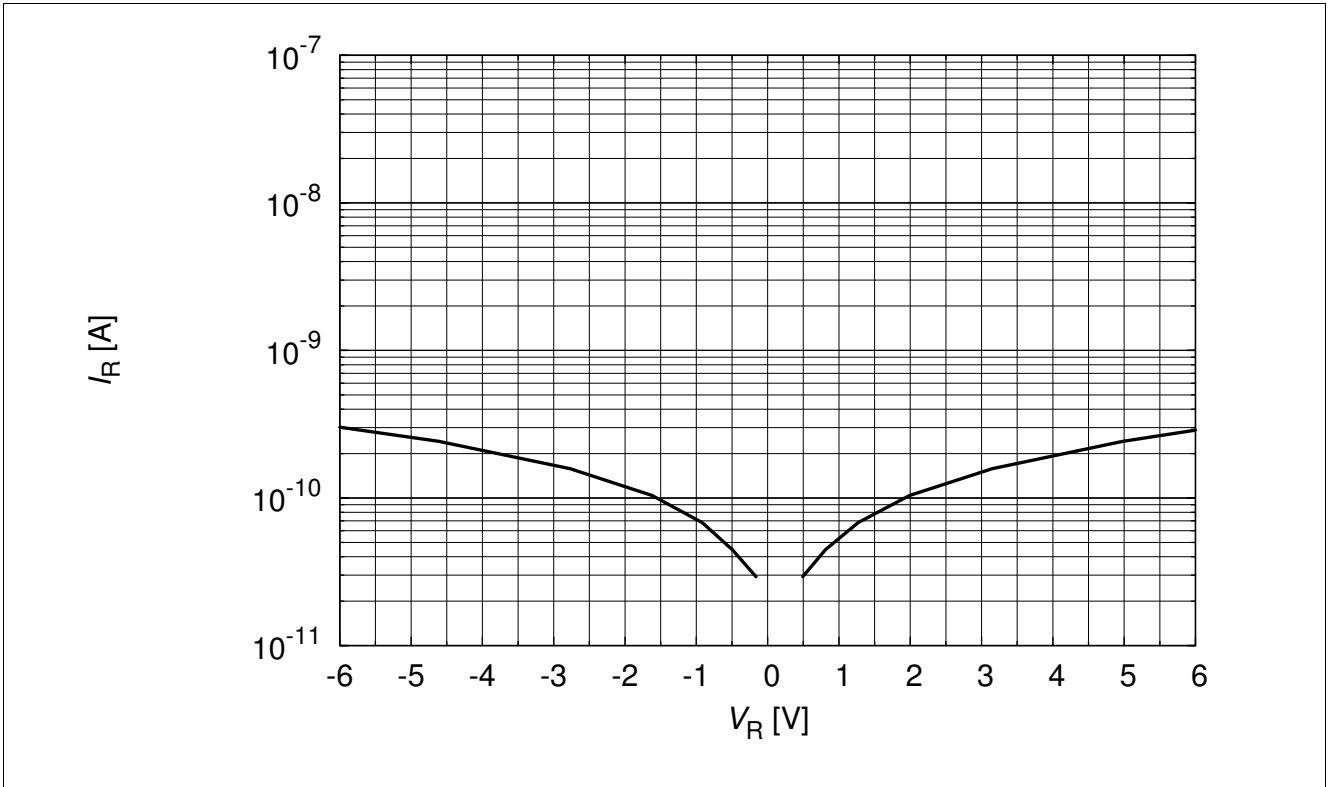

Figure 3 Reverse current: $I_R = f(V_R)$

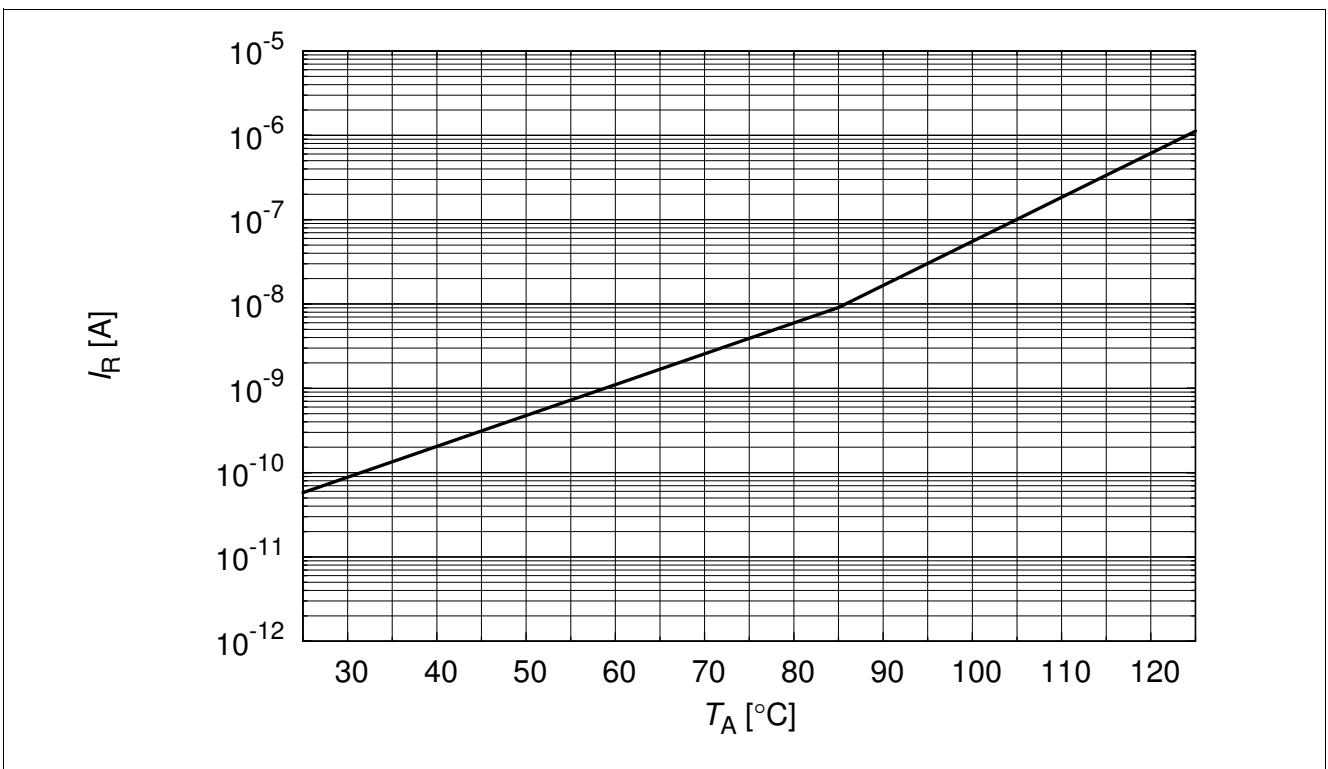

Figure 4 Reverse current: $I_R = f(T_A)$, $V_R = 5.5\text{ V}$

Typical Characteristics at $T_A = 25\text{ }^\circ\text{C}$, unless otherwise specified

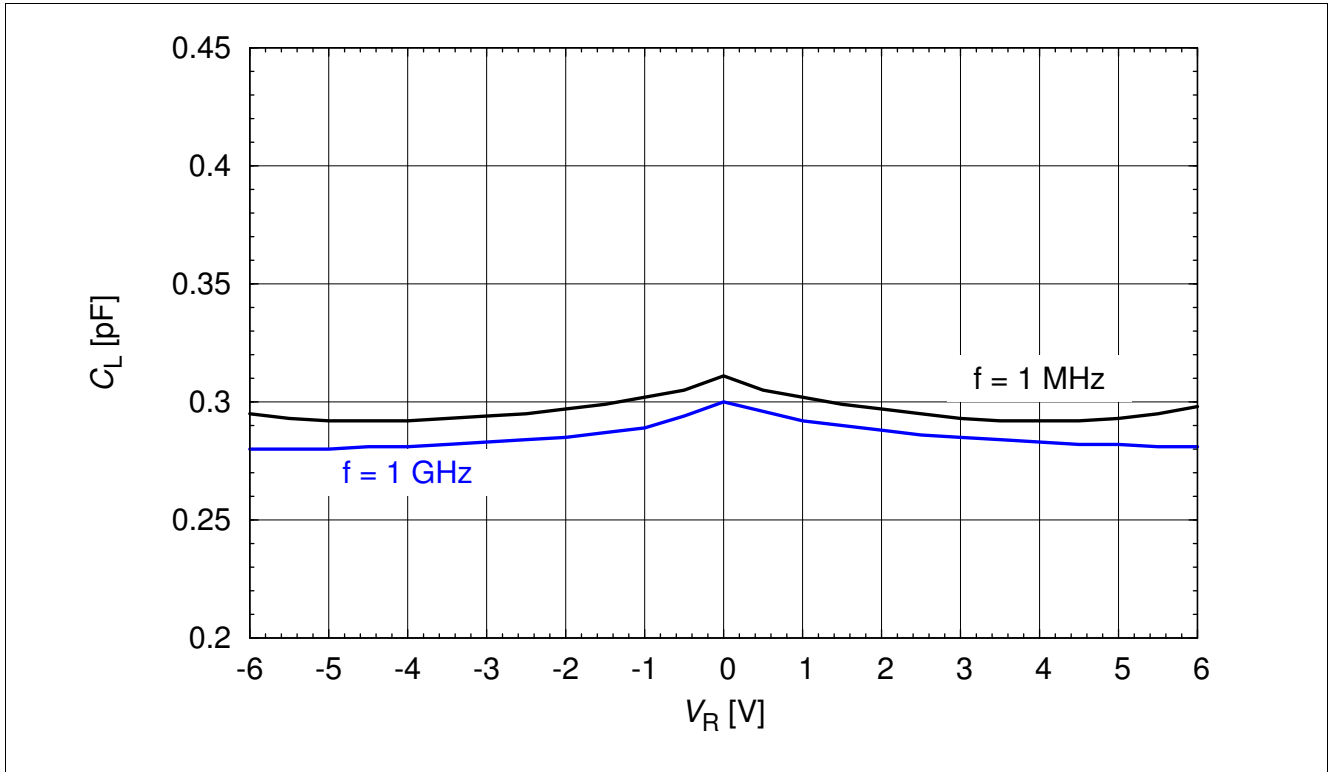

Figure 5 Line capacitance: $C_L = f(V_R), f = 1\text{ MHz}$

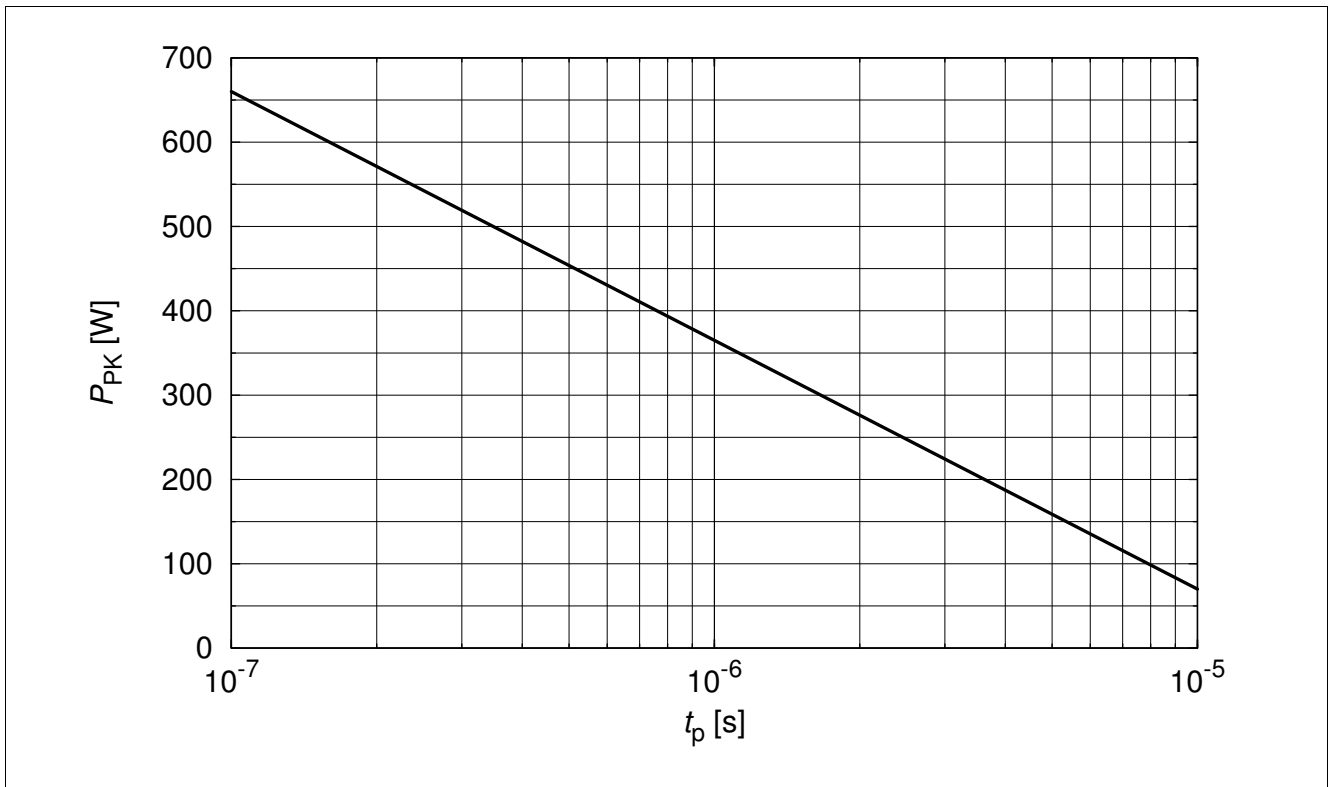

Figure 6 Peak pulse power: $P_{PK} = f(t_p)$

Typical Characteristics at $T_A = 25\text{ }^\circ\text{C}$, unless otherwise specified

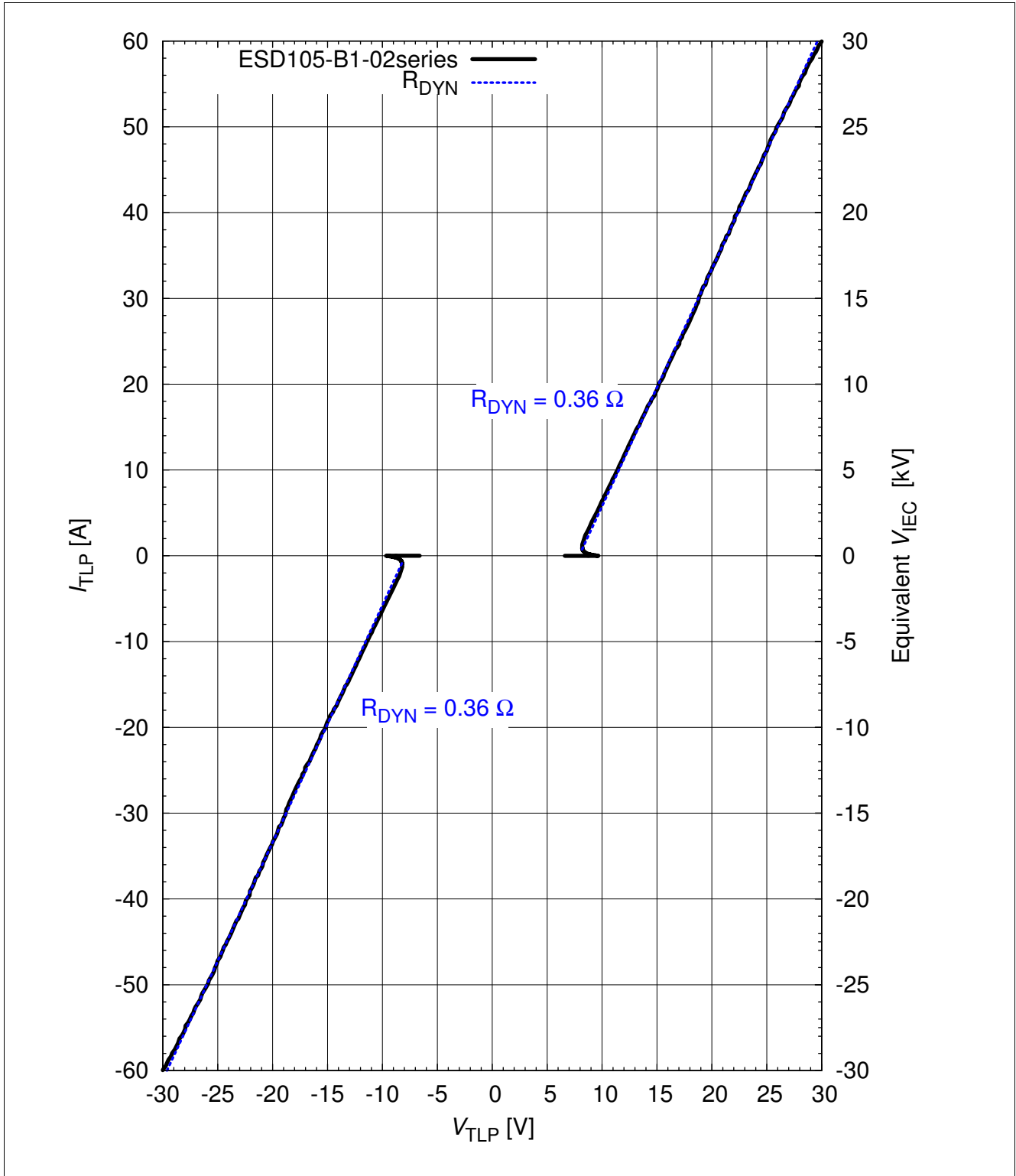

Figure 7 Clamping voltage (TLP): $I_{TLP} = f(V_{TLP})$ according ANSI/ESD STM5.5.1 - Electrostatic Discharge Sensitivity Testing using Transmission Line Pulse (TLP) Model. TLP conditions: $Z_0 = 50\ \Omega$, $t_p = 100\text{ ns}$, $t_r = 0.6\text{ ns}$, I_{TLP} and V_{TLP} averaging window: $t_1 = \text{ns}$ to $t_2 = 60\text{ ns}$, extraction of dynamic resistance using squares fit to TLP characteristics between $I_{TLP1} = 10\text{ A}$ and $I_{TLP2} = 50\text{ A}$. Please refer to Application Note AN210[1]

Typical Characteristics at $T_A = 25\text{ }^\circ\text{C}$, unless otherwise specified

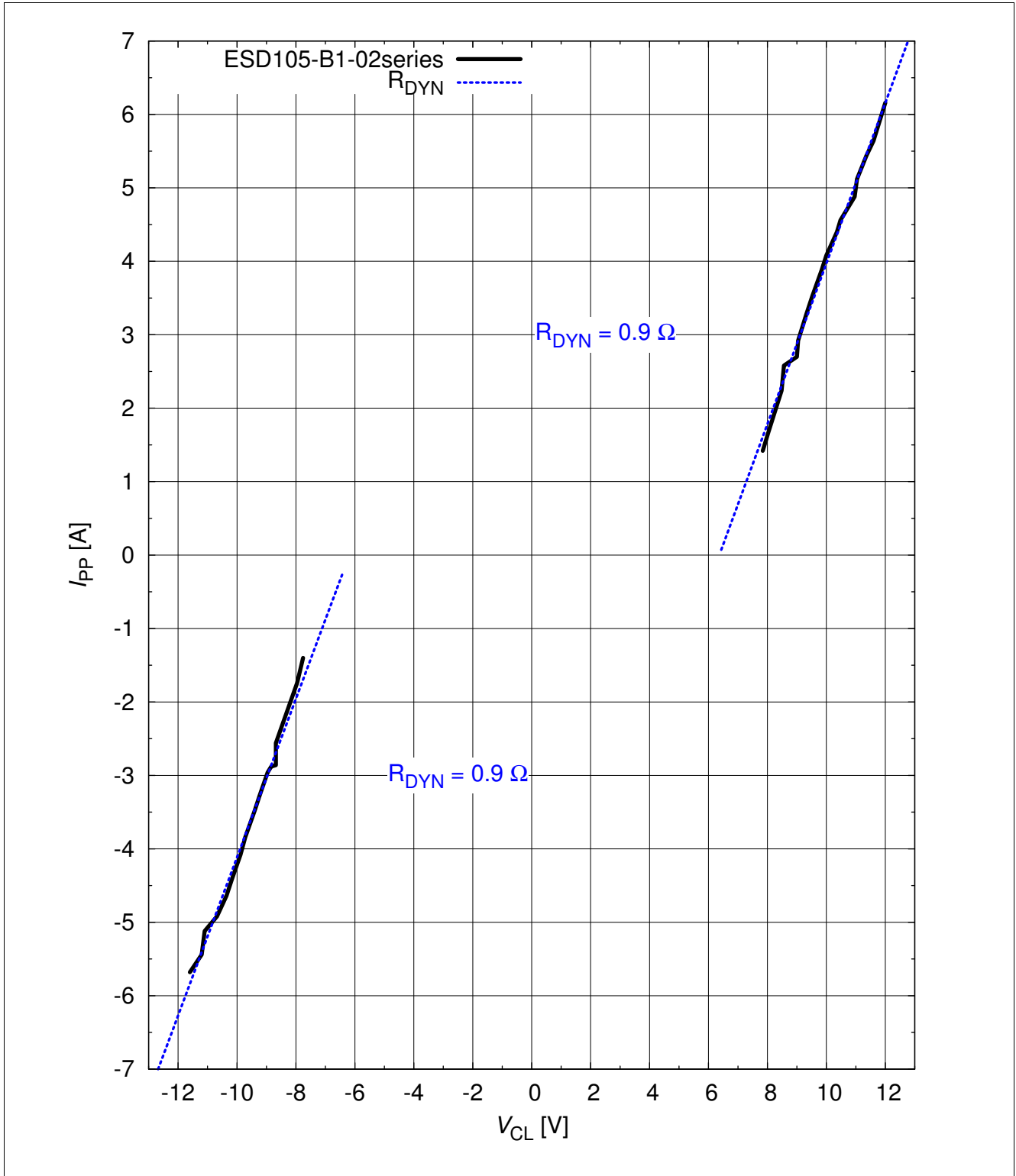

Figure 8 Pulse current (IEC61000-4-5) versus clamping voltage: $I_{PP} = f(V_{CL})$

Typical Characteristics at $T_A = 25\text{ }^\circ\text{C}$, unless otherwise specified

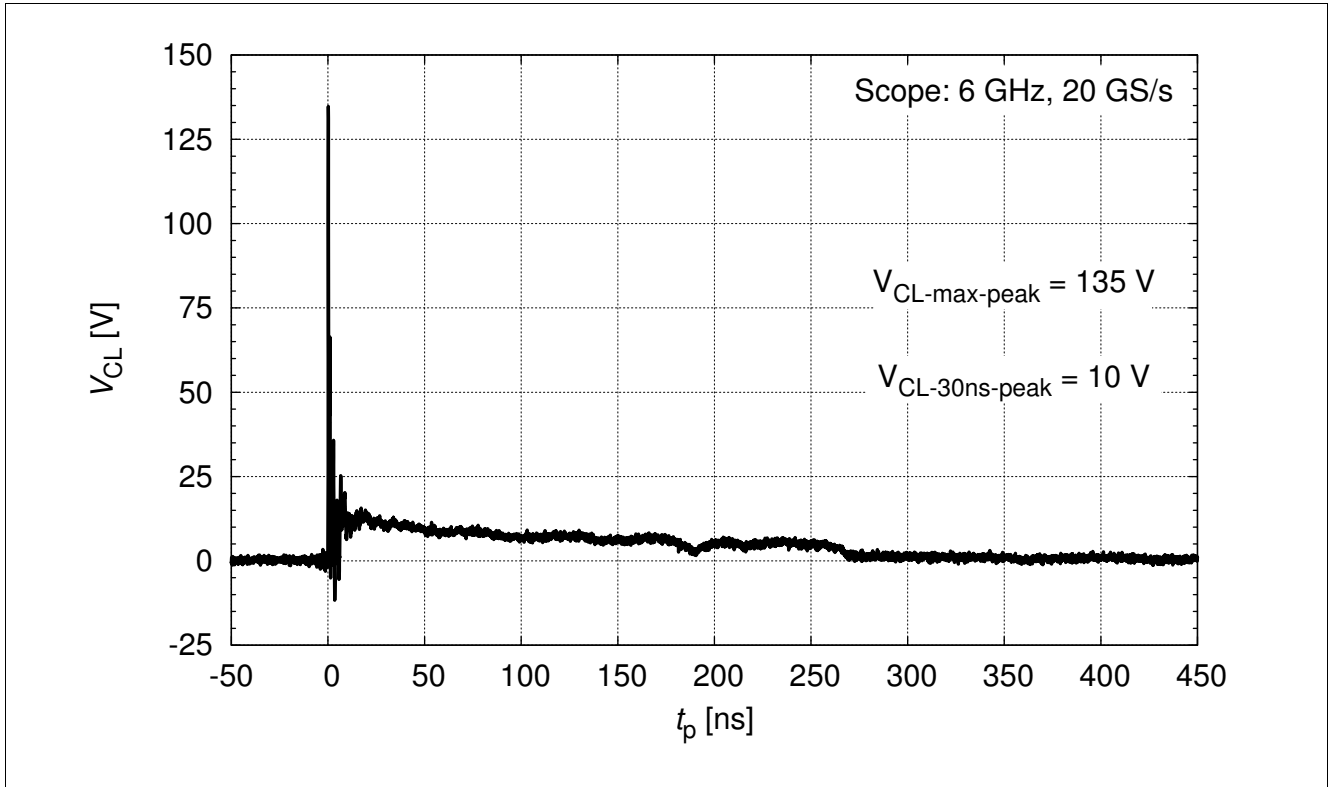

Figure 9 IEC61000-4-2: $V_{CL} = f(t)$, 8 kV positive pulse from pin 1 to pin 2

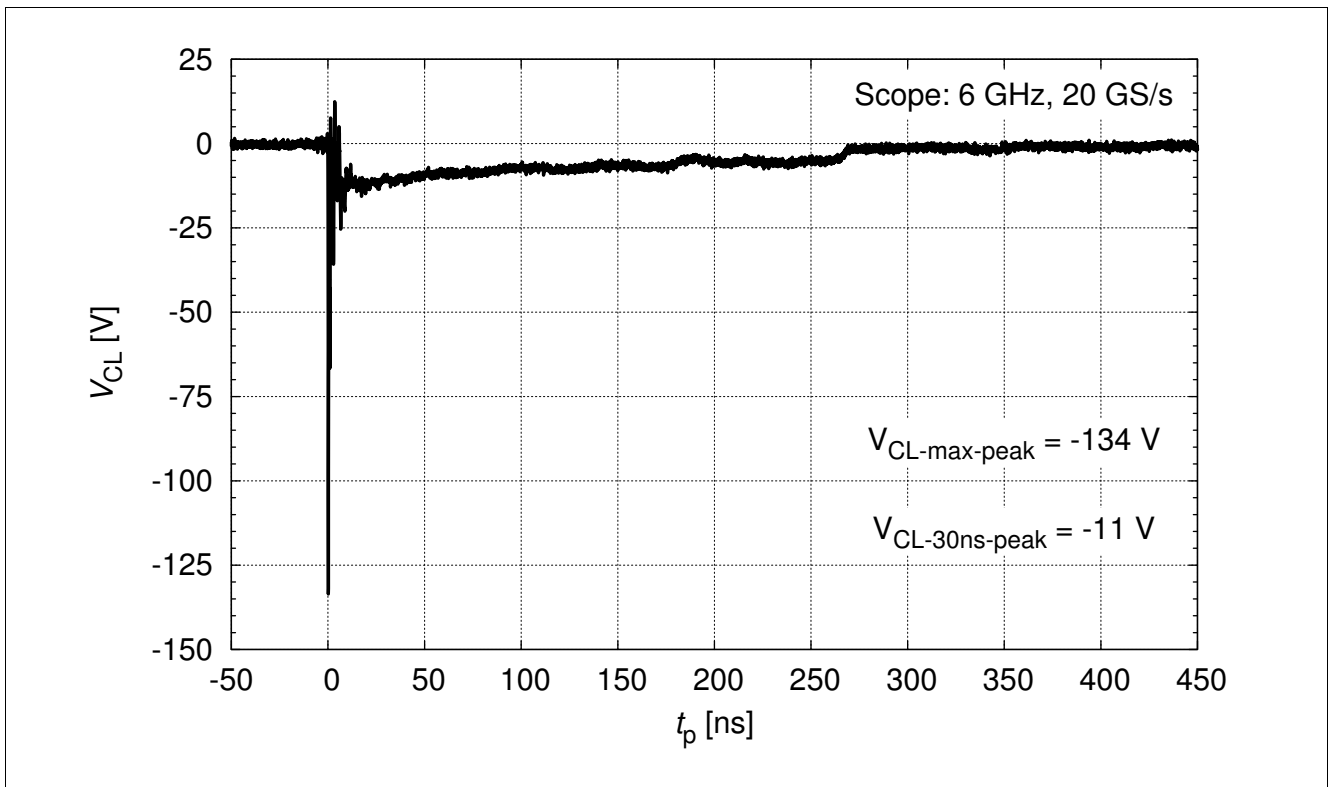

Figure 10 IEC61000-4-2: $V_{CL} = f(t)$, 8 kV negative pulse from pin 1 to pin 2

Typical Characteristics at $T_A = 25\text{ }^\circ\text{C}$, unless otherwise specified

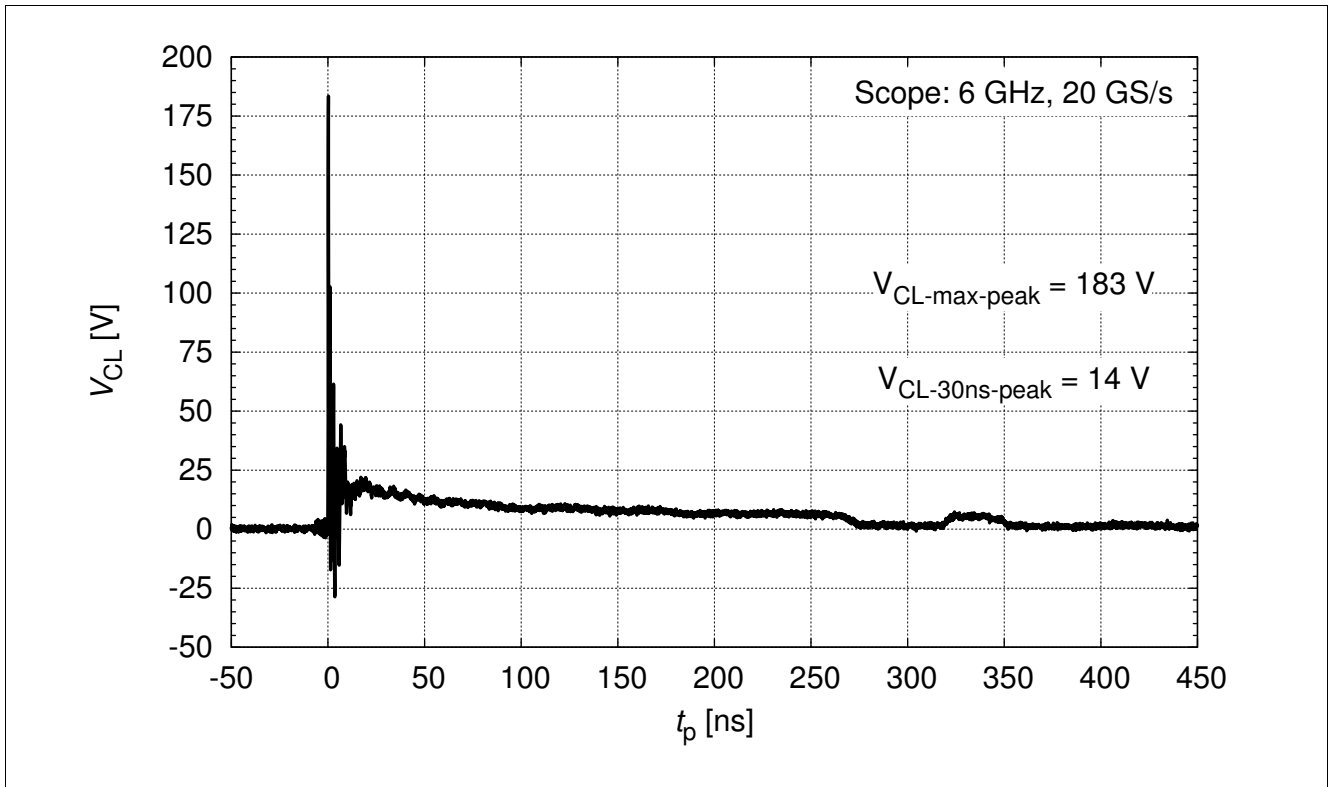

Figure 11 IEC61000-4-2: $V_{CL} = f(t)$, 15 kV positive pulse from pin 1 to pin 2

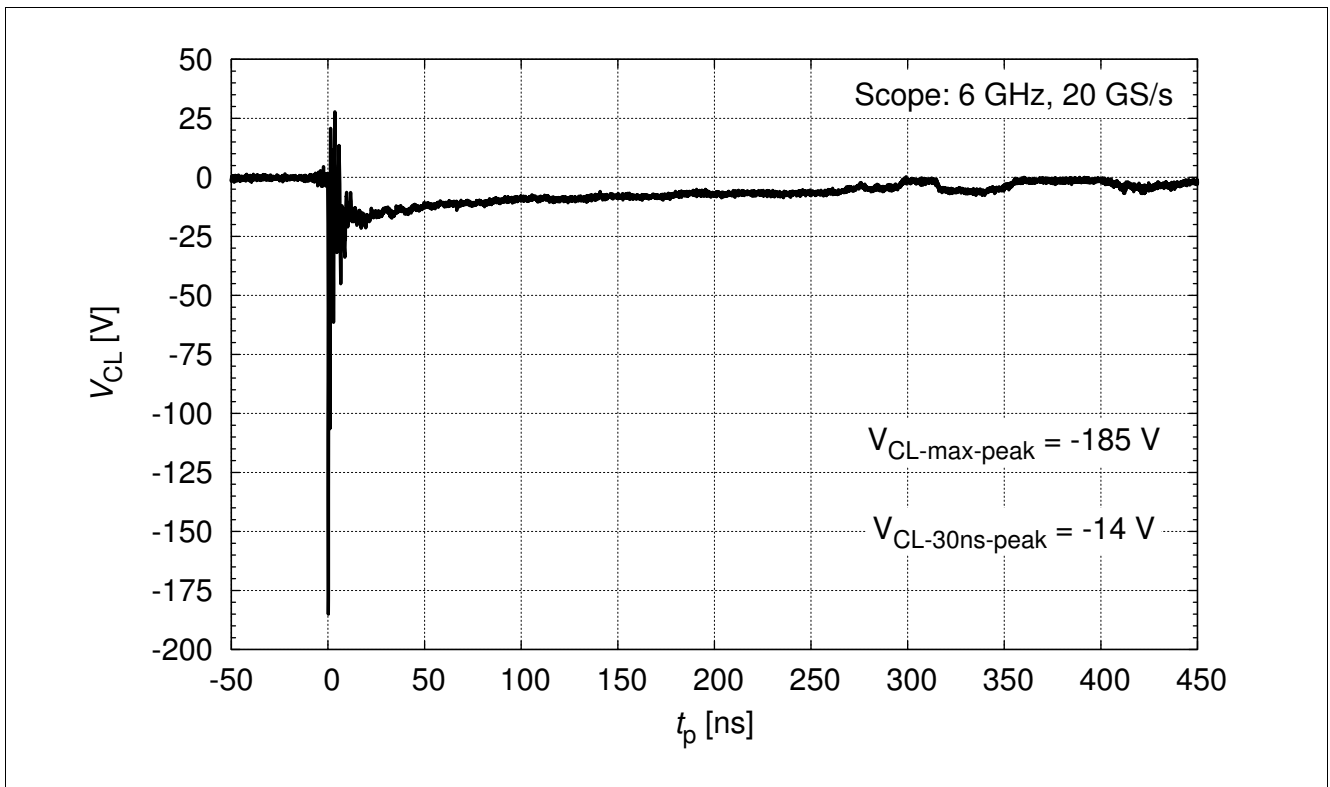

Figure 12 IEC61000-4-2: $V_{CL} = f(t)$, 15 kV negative pulse from pin 1 to pin 2

4 Application Information

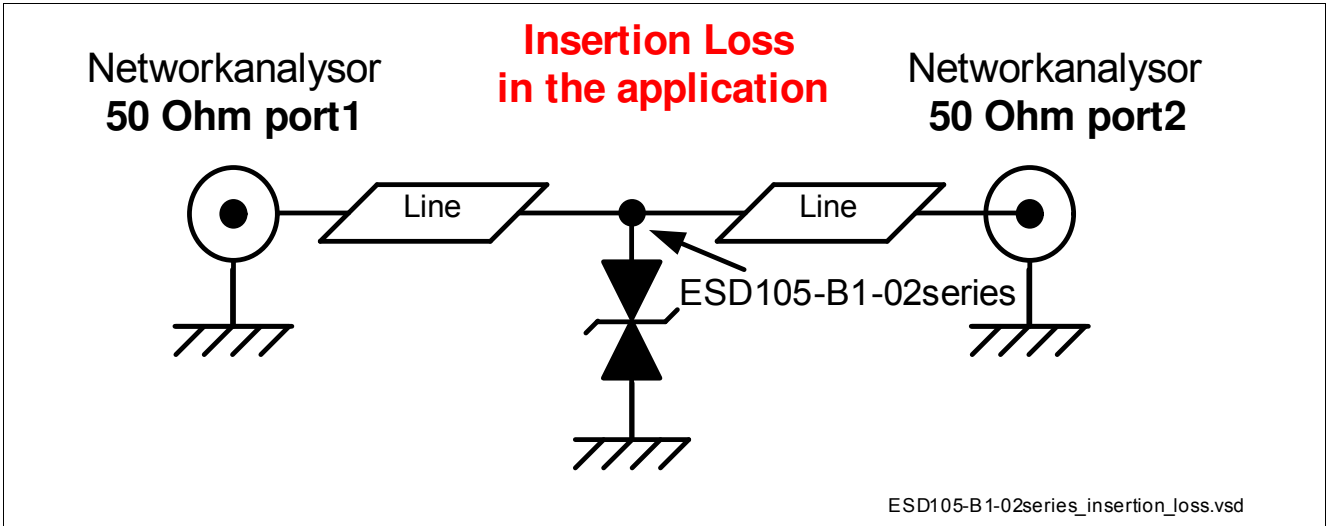

Figure 13 Insertion loss measured in 50 Ω environment

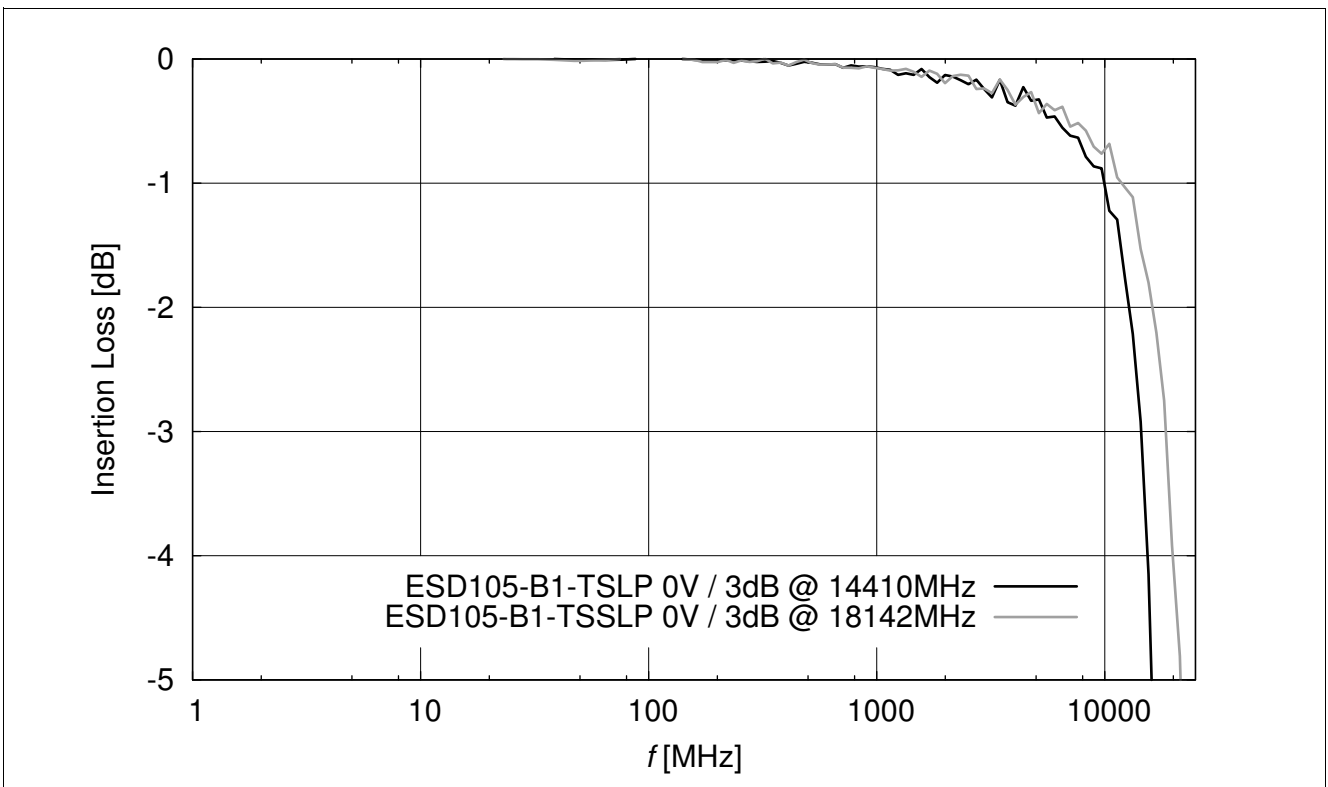

Figure 14 Insertion loss vs. frequency of ESD105-B1-02xx in a 50 Ω system

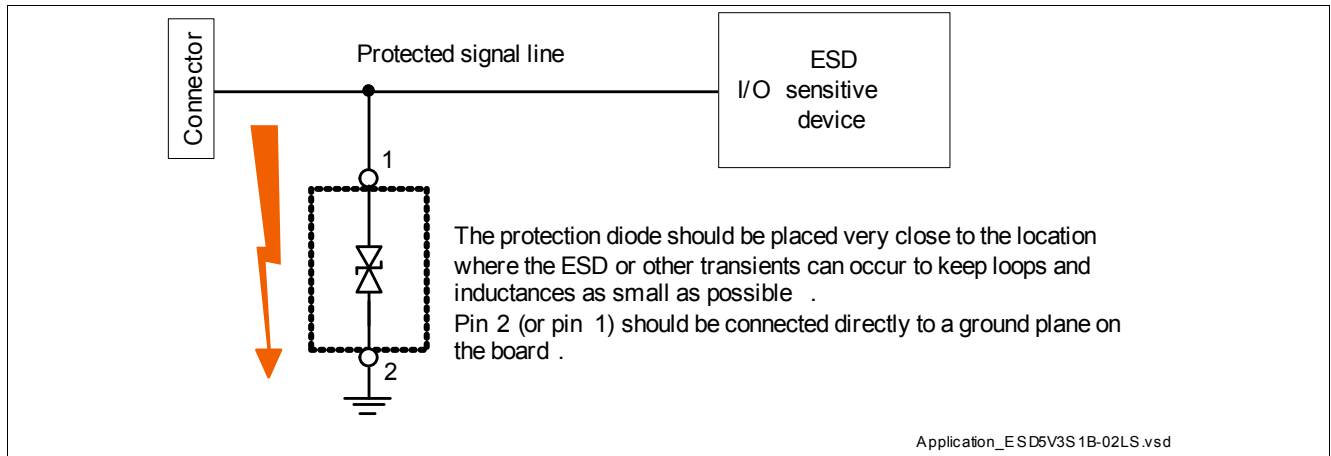

Figure 15 Single line, bi-directional ESD / Transient protection

5 Package Information

5.1 TSSLP-2-4

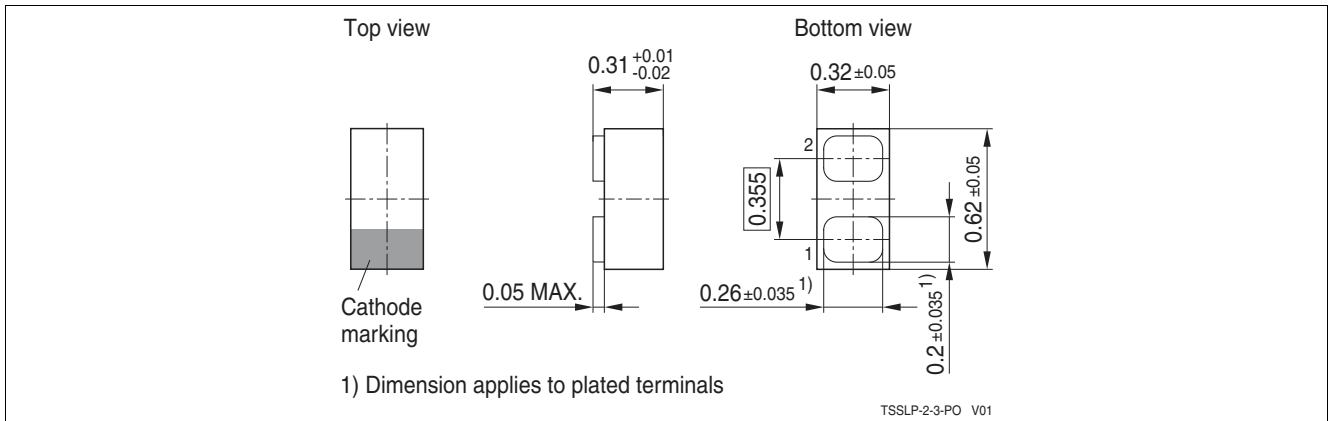

Figure 16 TSSLP-2-4 Package outline

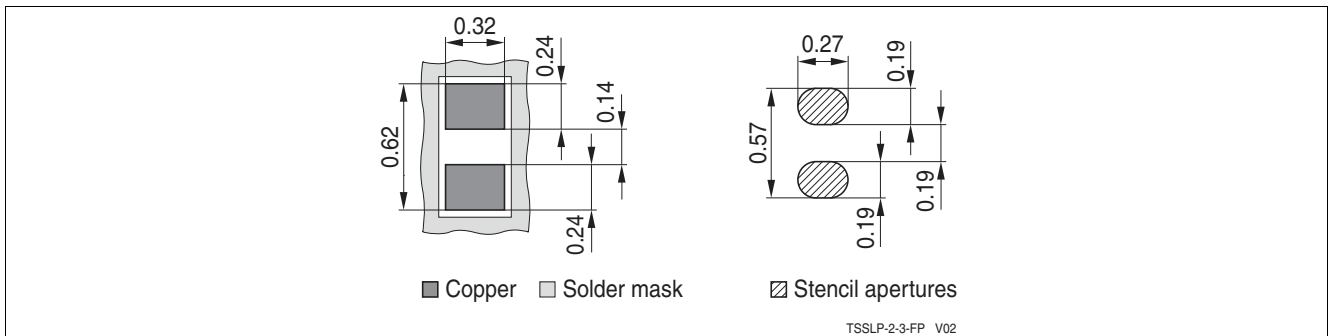

Figure 17 TSSLP-2-4 Footprint

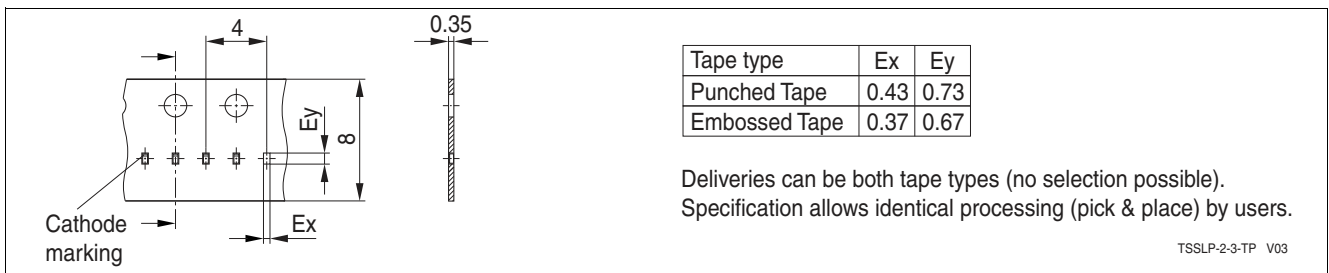

Figure 18 TSSLP-2-4 Packing

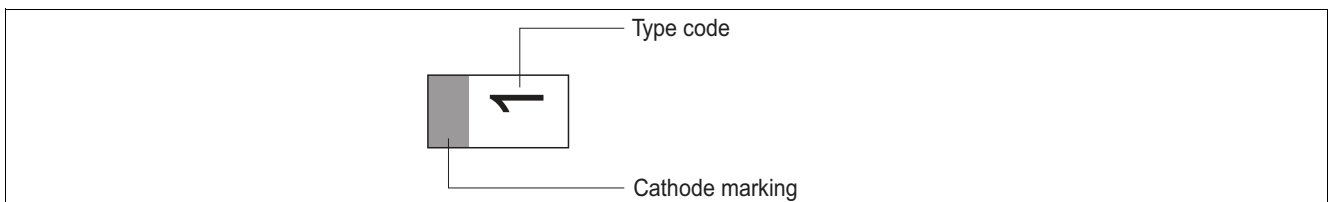

Figure 19 TSSLP-2-4 Marking (example)

5.2 TSLP-2-20

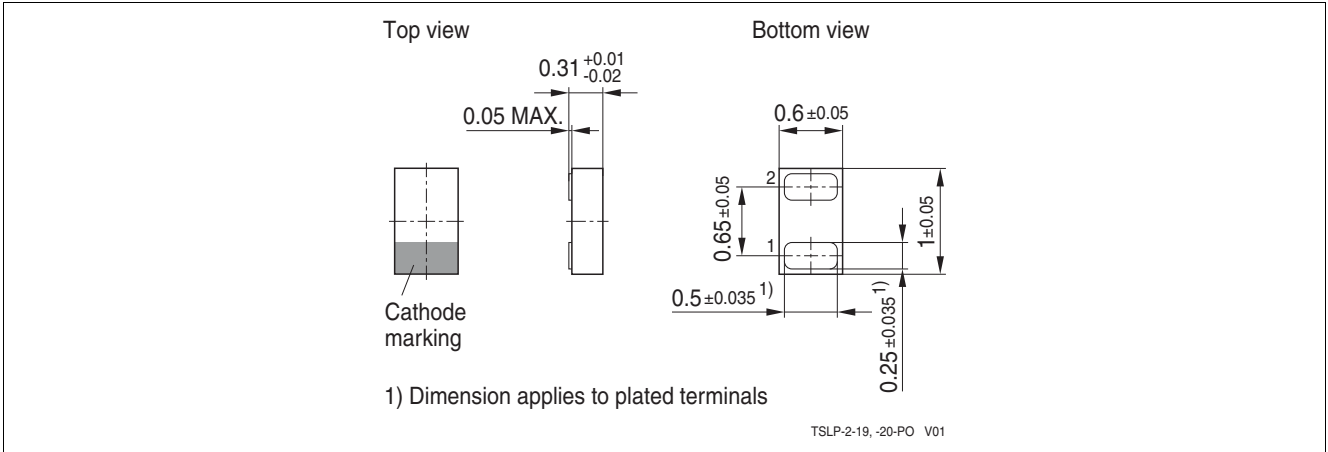

Figure 20 TSLP-2-20 Package outline

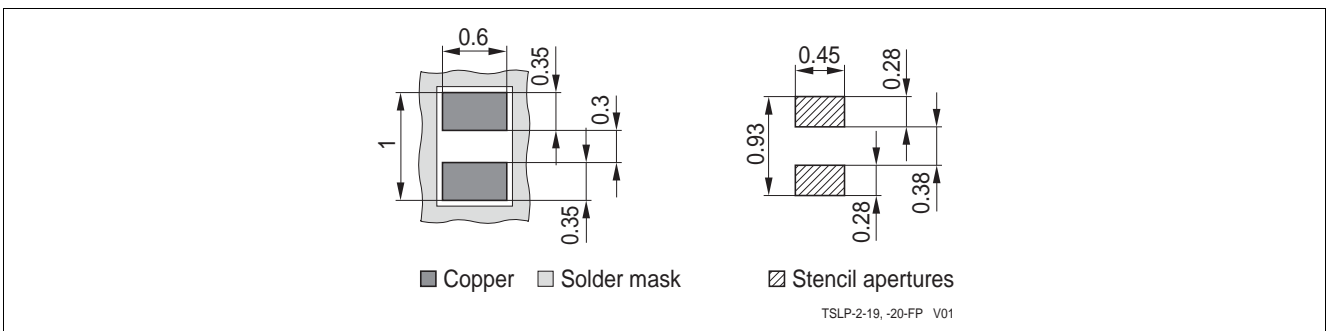

Figure 21 TSLP-2-20 Footprint

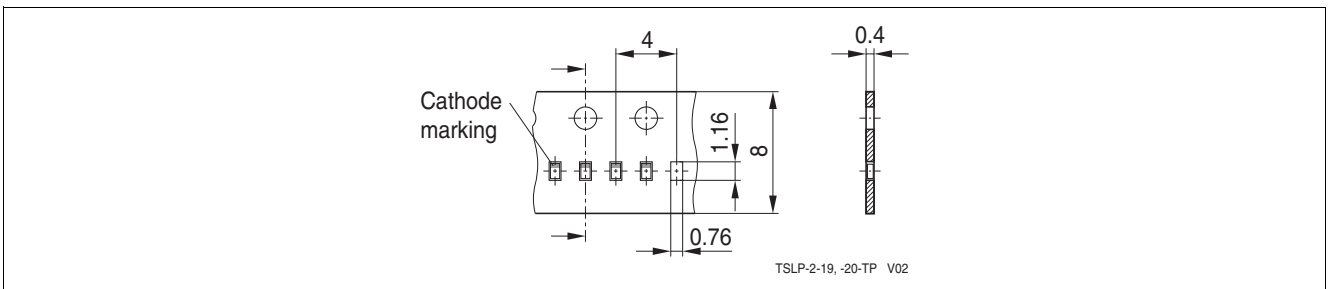

Figure 22 TSLP-2-20 Packing

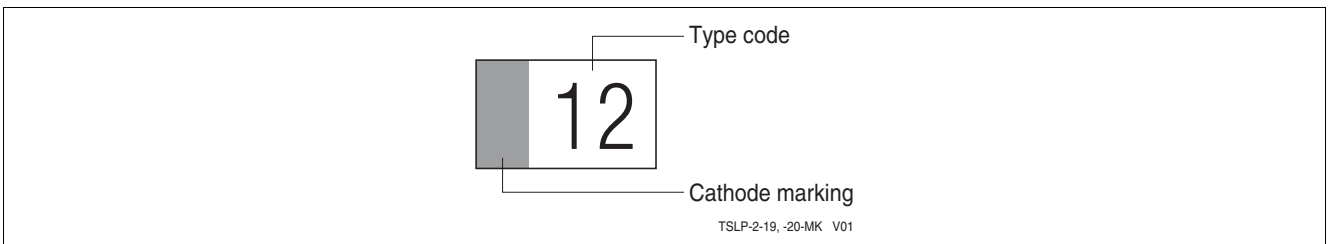

Figure 23 TSLP-2-20 Marking (example)

References

- [1] Infineon Technologies AG, "Effective ESD Protection Design at System Level Using VF-TLP Characterization Methodology", Application Note 210, RF and Protection Devices, April 22, 2010, Rev.1.0
- [2] Infineon AG - Recommendations for PCB Assembly of Infineon TSLP and TSSLP Packages

www.infineon.com

Published by Infineon Technologies AG