

THIS DRAWING IS UNPUBLISHED. RELEASED FOR PUBLICATION
 © COPYRIGHT BY TYCO ELECTRONICS CORPORATION. ALL RIGHTS RESERVED.

LOC	DIST	REVISIONS			
P	LTR	DESCRIPTION	DATE	OWN	APPD
CE	-	B1	OBSOLETE; MCO- 40024536MCO	13SEPT2015	HG TE

1. DIMENSIONS IN [] ARE IN INCHES
2. MAXIMUM INSERTION LOSS IS 0.5dB PLUS CABLE ATTENUATION OF 0.7dB/km AT 1310nm (SEE TABLE)
3. 50 dB MIN RETURN LOSS
4. PRODUCT AND PROCESSING MUST MEET REQUIREMENTS OF TYCO ELECTRONICS STANDARD 230-702

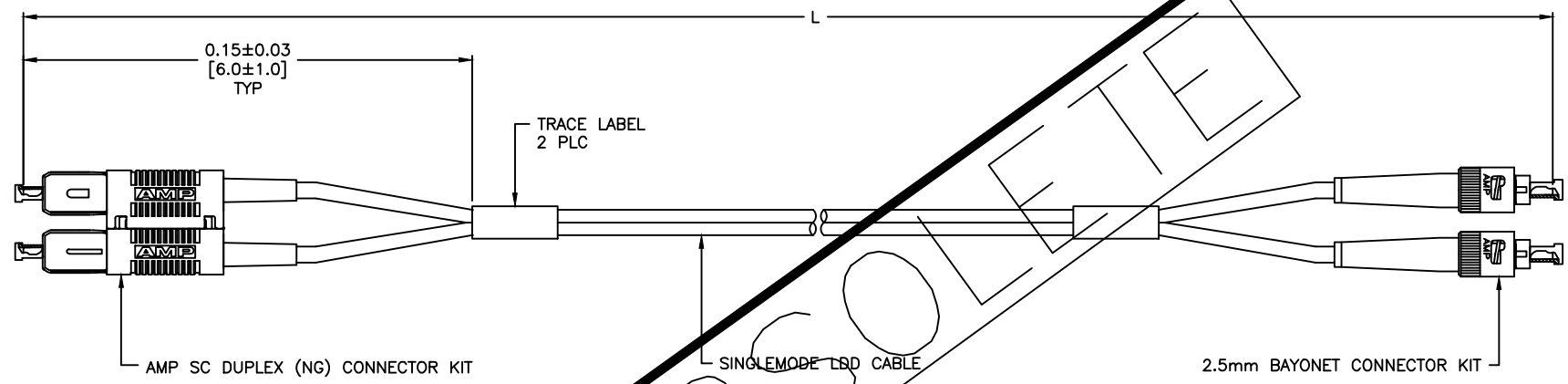

MAX IL (dB)	L METERS [INCHES]	PART NUMBER
0.50	12.00±0.15 [472.4±6.0]	1-5492020-2
0.60	144.78±0.61 [5700±24]	1-5492020-1
0.51	25±0.3 [984±12]	1-5492020-0
0.50	9±0.15 [354±6]	5492020-9
0.50	7±0.08 [276±3]	5492020-8
0.51	20±0.3 [787±12]	5492020-7
0.50	15±0.15 [591±6]	5492020-6
0.50	10±0.15 [394±6]	5492020-5
0.50	5±0.08 [197±3]	5492020-4
0.50	3±0.05 [118±2]	5492020-3
0.50	2±0.05 [79±2]	5492020-2
0.50	1±0.05 [39±2]	5492020-1

THIS DRAWING IS A CONTROLLED DOCUMENT.

DRW: C.S.VASU 02 JAN 06	CHK: J.DUNCAN 02 JAN 06	APPRO: J.DUNCAN 02 JAN 06	NAME: CABLE ASSEMBLY, FIBER OPTIC, SINGLEMODE LDD, AMP SC DUPLEX (NG) TO 2.5mm BAYONET, OPTIMATE
DIMENSIONS: METERS [INCHES]		TOLERANCES UNLESS OTHERWISE SPECIFIED:	SIZE: A2
0 PLC ± -	1 PLC ± -	2 PLC ± -	CAGE CODE: 00779
3 PLC ± -	4 PLC ± -	ANGLES ± -	DRAWING NO: C-5492020
MATERIAL: -	FINISH: -	WEIGHT: -	RESTRICTED TO: -
CUSTOMER DRAWING		SCALE: NTS	SHEET 1 OF 1 REV B1

Tyco Electronics Corporation
Harrisburg, Pa 17105-3608