

【1. 適用範囲 SCOPE】

本仕様書は、2.5mm/3.0 mm PITCH WIRE TO BOARD CONN. CRIMP REC TERM.

の圧着に伴う諸元について規定する。

This standard specifies the dimensions after crimping of the 2.5mm/3.5mm pitch wire to board conn. crimp rec terminal.

【2. 適用端子／電線 APPLICABLE TERMINAL／WIRE】

端子型番 Part Number	適用電線 WIRE SIZE		絶縁被覆外径 INSULATION DIAMETER
50535-9*01 87943-1*01	AWG # 1 6 ~ # 1 8	0.81~1.39mm ²	φ 2.0~ φ 2.45 mm

【3. 各部の名称 DEFINITION】

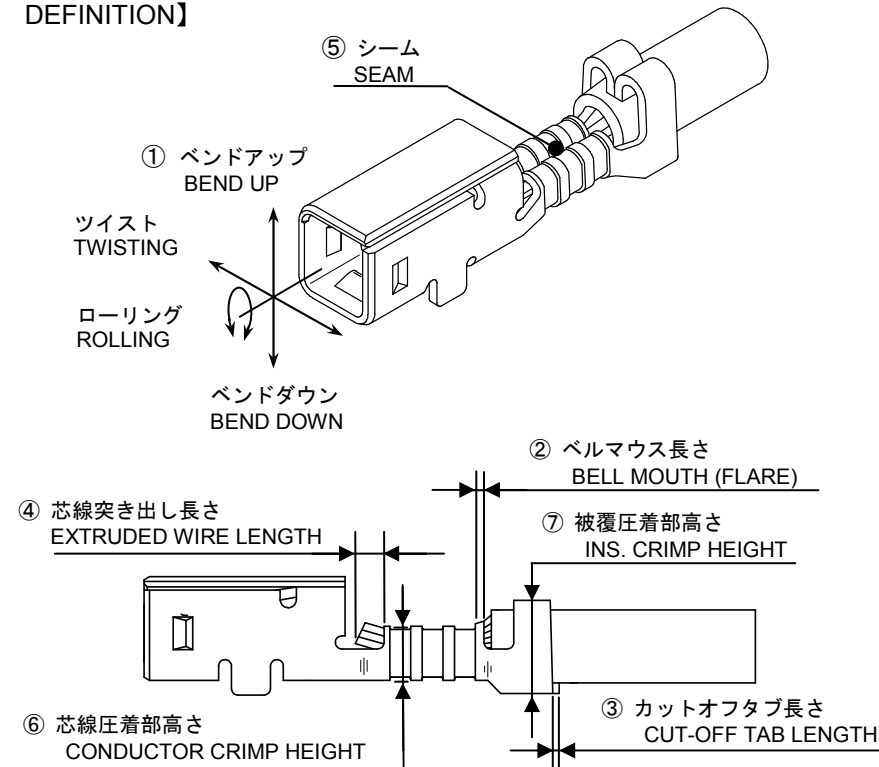

REV.	A																			
SHEET	1~4																			
REVISE ON PC ONLY										TITLE:										
A 新規作成 RELEASED J2013-0621 2012/11/29 KMATSUYAMA										2.5/3.0 mm PITCH WIRE TO BOARD CONN. CRIMP REC TERM. 圧着仕様書										
THIS DOCUMENT CONTAINS INFORMATION THAT IS PROPRIETARY TO INC. AND SHOULD NOT BE USED WITHOUT WRITTEN PERMISSION																				
REV.	DESCRIPTION																			
DESIGN CONTROL J					STATUS					WRITTEN BY: K.MATSUYAMA	CHECKED BY: K.ASAKAWA	APPROVED BY: YO.ITO	DATE: YR/MO/DAY 2012/11/29							
DOCUMENT NUMBER CS- 50535-001															FILE NAME CS50535001.DOC	SHEET 1 OF 4				
EN-037(2012-05)																				

【4. 仕様 SPECIFICATION】

番号 NUMBER	項目 ITEM	仕様 REQUIREMENT
①	バンドアップ BEND UP	3° 以下 / MAX.
	バンドダウン BEND DOWN	2° 以下 / MAX.
	ツイスト TWISTING	3° 以下 / MAX.
	ロールング ROOLING	5° 以下 / MAX.
②	ベルマウス (参考値) BELL MOUTH (REF.)	0. 2 ~ 0. 7 mm
③	カットオフタブ長さ CUT OFF TAB LENGTH	0. 2 mm以下 / MAX
④	芯線突き出し長さ EXTRUDED WIRE LENGTH	0 ~ 1. 0 mm
⑤	シーム SEAM	シームは閉じていること。但し、 開きのある場合は芯線の飛び出しのないこと。 SEAM SHALL NOT BE OPENED AND NOT WIRE ALLOWED OUT OF CRIMPING AREA
⑥	芯線圧着部高さ CONDUCTOR CRIMP HEIGHT	第5項参照 REFER TO PARAGRAPH 5
⑦	被覆圧着部高さ INS.CRIMP HEIGHT	第5項参照 REFER TO PARAGRAPH 5
≠	絶縁被覆むき長さ (参考値) WIRE STRIP LENGTH (REF.)	3. 7 ~ 4. 2 mm

【5. 圧着条件 (⑥及び⑦) CONDITIONS】

AWG# 16 ~ # 18

電線 (UL 1007相当) を圧着した際の要件は下記による。

AFTER CRIMPING THE WIRE (EQUIVALENT TO UL1007), THE CRIMPED AREAS SHOULD BE AS FOLLOWS.

電線サイズ WIRE SIZE (AWG)	圧着機番号 CRIMP DIE MODEL NO.	⑥芯線圧着部高さ CONDUCTOR CRIMP HEIGHT		⑦被覆圧着部 INSULATION		圧着部引張強度 CRIMP STRENGTH (N {Kgf})
		工具マーク TOOL MARK	高さ HEIGHT	工具マーク TOOL MARK	参考高さ HEIGHT	
# 1 6	57319-3000	B	1. 5 1 ~ 1. 6 1 mm	5	3. 1 ~ 3. 3 mm	127.4{13.0}以上 / MIN.
# 1 8		A	1. 3 3 ~ 1. 4 3 mm	4		88.2{9.0}以上 / MIN.

REVISE ON PC ONLY		TITLE: 2.5/3.0 mm PITCH WIRE TO BOARD CONN. CRIMP REC TERM. 圧着仕様書
A	SEE SHEET 1 OF 4	
REV.	DESCRIPTION	THIS DOCUMENT CONTAINS INFORMATION THAT IS PROPRIETARY TO INC. AND SHOULD NOT BE USED WITHOUT WRITTEN PERMISSION
DOCUMENT NUMBER CS-50535-001		FILE NAME CS50535001.DOC
		SHEET 2 OF 4

【6. 消耗部品一覧 PERISHABLE PARTS LIST】

部品名称 PART NAME	部品番号 PART NUMBER
アンビル ANVIL	5 7 3 1 9 - 2 0 0 1
芯線クリンプパンチ COND.PUNCH	5 7 3 1 9 - 2 0 0 2
被覆クリンプパンチ INS.PUNCH	5 7 3 1 9 - 2 0 0 3
フロントホルダー FRONT HOLDER	5 7 0 9 5 - 2 0 0 1
フロントフローティングシェア FRONT FLOATING SHEAR	5 7 0 9 5 - 2 0 0 2

A	REVISE ON PC ONLY	TITLE: 2.5/3.0 mm PITCH WIRE TO BOARD CONN. CRIMP REC TERM. 圧着仕様書	
	SEE SHEET 1 OF 4		
REV.	DESCRIPTION	THIS DOCUMENT CONTAINS INFORMATION THAT IS PROPRIETARY TO INC. AND SHOULD NOT BE USED WITHOUT WRITTEN PERMISSION	
DOCUMENT NUMBER CS-50535-001		FILE NAME CS50535001.DOC	SHEET 3 OF 4
EN-037(2012-05)			

