

NA シリーズ
SERIES

85°C 両極性小形化標準品
85°C Bi-polar Miniaturized

RoHS
compliance

新規採用非推奨品
NOT recommended for new designs

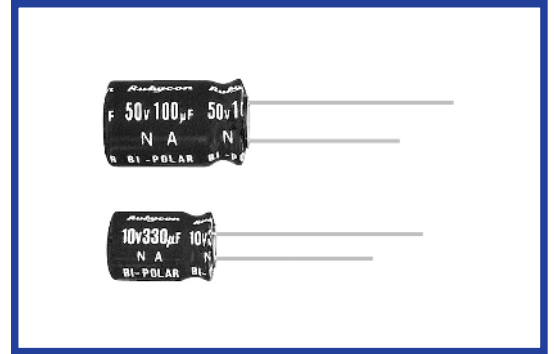

◆規格表 / SPECIFICATIONS

項目 Items	特性 Characteristics																														
カテゴリ温度範囲 Category Temperature Range	-40~+85°C																														
定格電圧範囲 Rated Voltage Range	6.3~100Vdc																														
静電容量許容差 Capacitance Tolerance	±20% (20°C, 120Hz)																														
漏れ電流 Leakage Current (MAX)	I=0.03CV又は3µAのいずれか大なる値以下 (定格電圧印加5分後) I=0.03CV or 3µA whichever is greater. (After 5 minutes application of rated voltage) I=漏れ電流(µA) Leakage Current C=静電容量(µF) Capacitance V=定格電圧(Vdc) Rated Voltage																														
損失角の正接 (tanδ) Dissipation Factor (MAX)	<table border="1"> <tr> <td>定格電圧(Vdc) Rated Voltage</td> <td>6.3</td> <td>10</td> <td>16</td> <td>25</td> <td>35</td> <td>50</td> <td>63</td> <td>100</td> <td>(20°C, 120Hz)</td> </tr> <tr> <td>tanδ</td> <td>0.25</td> <td>0.25</td> <td>0.20</td> <td>0.20</td> <td>0.15</td> <td>0.15</td> <td>0.15</td> <td>0.15</td> <td></td> </tr> </table>	定格電圧(Vdc) Rated Voltage	6.3	10	16	25	35	50	63	100	(20°C, 120Hz)	tanδ	0.25	0.25	0.20	0.20	0.15	0.15	0.15	0.15											
定格電圧(Vdc) Rated Voltage	6.3	10	16	25	35	50	63	100	(20°C, 120Hz)																						
tanδ	0.25	0.25	0.20	0.20	0.15	0.15	0.15	0.15																							
耐久性 Endurance	85°C中で250時間毎に極性を反転させ2000時間定格電圧(リップル重畳)印加後、下記項目を満足すること。 After applying rated voltage with rated ripple current for 2000 hours at 85°C, (The polarity shall be reversed every 250hrs.), the capacitors shall meet the following requirements. <table border="1"> <tr> <td>静電容量変化率 Capacitance Change</td> <td>初期値の±25%以内 Within ±25% of the initial value.</td> </tr> <tr> <td>損失角の正接 Dissipation Factor</td> <td>規格値の200%以下 Not more than 200% of the specified value.</td> </tr> <tr> <td>漏れ電流 Leakage Current</td> <td>規格値以下 Not more than the specified value.</td> </tr> </table>	静電容量変化率 Capacitance Change	初期値の±25%以内 Within ±25% of the initial value.	損失角の正接 Dissipation Factor	規格値の200%以下 Not more than 200% of the specified value.	漏れ電流 Leakage Current	規格値以下 Not more than the specified value.																								
静電容量変化率 Capacitance Change	初期値の±25%以内 Within ±25% of the initial value.																														
損失角の正接 Dissipation Factor	規格値の200%以下 Not more than 200% of the specified value.																														
漏れ電流 Leakage Current	規格値以下 Not more than the specified value.																														
低温特性 Low Temperature Stability (インピーダンス比) Impedance Ratio (MAX)	<table border="1"> <tr> <td>定格電圧(Vdc) Rated Voltage</td> <td>6.3</td> <td>10</td> <td>16</td> <td>25</td> <td>35</td> <td>50</td> <td>63</td> <td>100</td> <td>(120Hz)</td> </tr> <tr> <td>Z(-25°C)/Z(20°C)</td> <td>6</td> <td>4</td> <td>4</td> <td>3</td> <td>2</td> <td>2</td> <td>2</td> <td>2</td> <td></td> </tr> <tr> <td>Z(-40°C)/Z(20°C)</td> <td>12</td> <td>10</td> <td>8</td> <td>6</td> <td>4</td> <td>4</td> <td>4</td> <td>3</td> <td></td> </tr> </table>	定格電圧(Vdc) Rated Voltage	6.3	10	16	25	35	50	63	100	(120Hz)	Z(-25°C)/Z(20°C)	6	4	4	3	2	2	2	2		Z(-40°C)/Z(20°C)	12	10	8	6	4	4	4	3	
定格電圧(Vdc) Rated Voltage	6.3	10	16	25	35	50	63	100	(120Hz)																						
Z(-25°C)/Z(20°C)	6	4	4	3	2	2	2	2																							
Z(-40°C)/Z(20°C)	12	10	8	6	4	4	4	3																							

◆リップル電流補正係数 / MULTIPLIER FOR RIPPLE CURRENT

周波数係数 Frequency coefficient

周波数 (Hz) Frequency	60(50)	120	500	1k	10k≤
1µF	0.50	1.00	1.20	1.30	1.50
2.2~4.7µF	0.65	1.00	1.20	1.30	1.50
10~47µF	0.80	1.00	1.20	1.30	1.50
100~1000µF	0.80	1.00	1.10	1.15	1.20

◆副記号 / OPTION

	記号 Code
PETスリーブ PET Sleeve	EFC

◆呼称方法 / PART NUMBER

□□□	NA	□□□□□	M	□□□	□□	D×L
定格電圧 Rated Voltage	シリーズ名 Series	静電容量 Capacitance	静電容量許容差 Capacitance Tolerance	副記号 Option	リード加工記号 Lead Forming	ケースサイズ Case Size

◆寸法図 / DIMENSIONS

(mm)

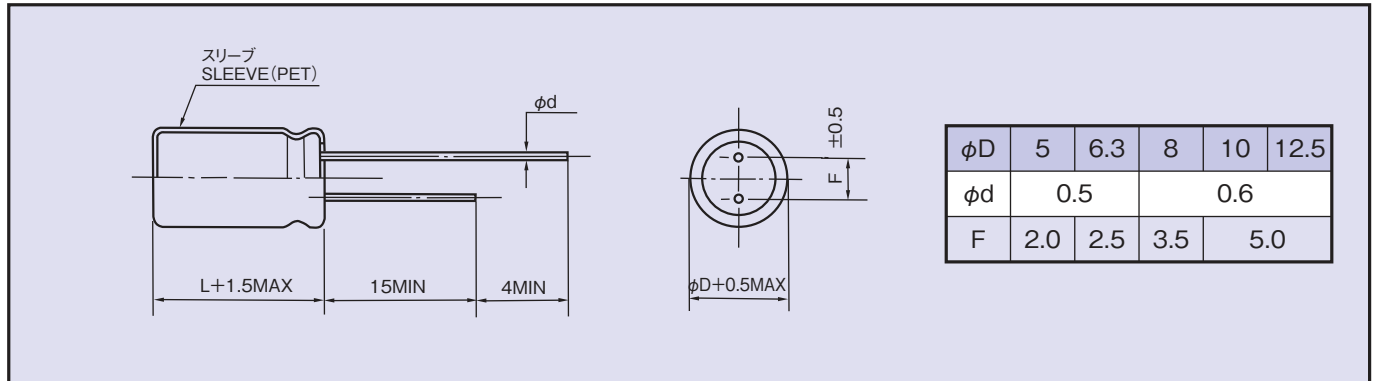

◆標準品一覧表 / STANDARD SIZE

Size $\phi D \times L$ (mm), Rated Ripple Current (mA r.m.s./85°C, 120Hz)

定格電圧 Vdc 静電容量 Cap(μF)	6.3		10		16		25	
	Size	Ripple	Size	Ripple	Size	Ripple	Size	Ripple
33							5×11	77
47					5×11	80	6.3×11	100
100	5×11	100	6.3×11	115	6.3×11	130	8×11.5	175
220	6.3×11	160	8×11.5	205	8×11.5	220	10×12.5	295
330	8×11.5	225	8×11.5	240	10×12.5	325	10×16	380
470	8×11.5	250	10×12.5	345	10×16	415	10×20	510
1000	10×16	425	10×20	550	12.5×20	695		

定格電圧 Vdc 静電容量 Cap(μF)	35		50		63		100	
	Size	Ripple	Size	Ripple	Size	Ripple	Size	Ripple
1			5×11	12			5×11	15
2.2			5×11	19			5×11	20
3.3			5×11	25			5×11	27
4.7			5×11	35	5×11	35	6.3×11	37
10			5×11	40	6.3×11	45	8×11.5	65
22	5×11	65	6.3×11	72	8×11.5	82	10×12.5	96
33	6.3×11	90	6.3×11	95	8×11.5	100	10×16	125
47	6.3×11	110	8×11.5	130	10×12.5	140	10×20	165
100	10×12.5	220	10×16	235	10×20	250	12.5×25	285
220	10×20	390	12.5×20	460	12.5×25	490		
330	12.5×20	540	12.5×25	590				
470	12.5×25	640						