

FP-XMLPAB

Extra Medium Low Profile Flat Panel
Articulating Wall Mount

Product Features:

Holds most 32" – 52" flat panels

Maximum flat panel hole pattern – 600mm x 400mm

Depth – 1.5" to 16.2"

Adjustable tilt -2° to $+10^{\circ}$ / Rotates $\pm 45^{\circ}$

List adjustment $\pm 3^{\circ}$

Integrated cable management system and level

Load capacity - 100 lbs

Black powder coat finish

Product Specifications:

(for Architects & Engineers)

The low profile articulating wall mount for the 32" to 52" flat panel display shall be the Video Mount Products (VMP) FP-XMLPAB. The mount shall be designed to attach to 2 studs approximately 16" apart or other suitable support surface.

The mount shall be constructed primarily of formed steel and aluminum and shall incorporate arc welds. The mount shall be a universal style mount capable of adjusting to the dimensions of a variety of popular 32" to 52" flat panel displays and not necessarily be model specific. The adjustable mounting rails shall be capable of accommodating a maximum hole pattern of 600 mm wide and 400 mm tall.

The mount shall have an adjustable distance from wall that ranges between 1.5" to 16.2". The mount shall be capable of tilting from -2° to $+10^{\circ}$. The mount shall incorporate post install level correction capability of $\pm 3^{\circ}$. The mounting rails shall be capable of accepting a pad lock to further secure the flat panel against theft. The load capacity shall be 100 lbs.

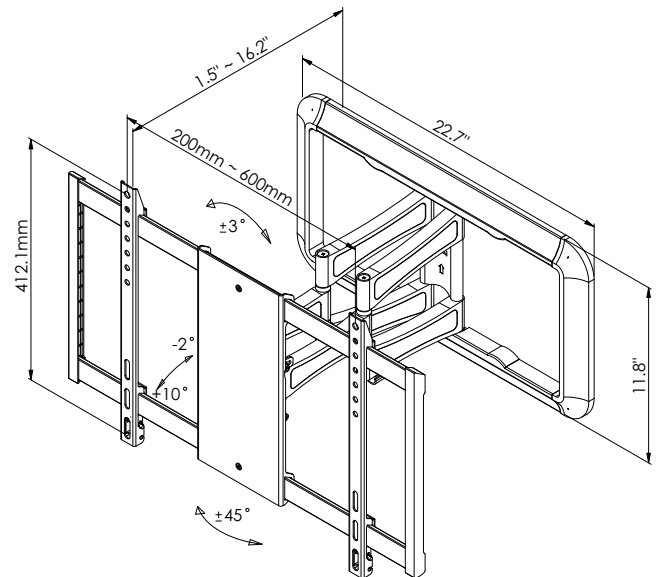

Video Mount Products

345 Log Canoe Circle

Stevensville, MD 21666

Toll Free: 877.281.2169

Telephone: 410.643.6390

Facsimile: 410.643.6615

www.videomount.com

VMP
VIDEO MOUNT PRODUCTS