

High precision

TOPGNSS^R

Professional GNSS wireless solutions provider

Model : TOP106

GNSS Antenna

STOTON

High-precision GNSS Antenna



TOPGNSS TOP106 four-system 7-band measurement antenna can simultaneously support GNSS multi-frequency signals: GPS L1, L2 and Beidou B1, B2, B3 / GLONASS L1 L2 frequency band signals. The multi-feed antenna design ensures the coincidence of the antenna phase center and the geometric center and improves the measurement accuracy. Built-in low-noise amplifier module, pre-stage and multi-stage filters can filter out interference signals to ensure normal operation in harsh electromagnetic environments. The radome is made of high-temperature-resistant PC material.

The plastic adopts a streamlined design and is widely used in geodetic surveying, bridge construction, ocean surveying, underwater topographic surveying, unmanned aerial vehicles, unmanned vehicles, unmanned ships and other high-precision positioning and navigation timeout fields.

1. Antenna characteristics

频率范围 (Frequency Range)	1555~1615MHz / 1198~1278MHz
端口阻抗 (port Impedance)	50 Ohm
极化方式 (Polarization)	右旋圆极化 (RHCP)
天线轴比 (Axial Ratio)	≤3dB
水平面覆盖角度 (Elevation Coverage)	360°
电压驻波比 (VSWR)	≤2
天线单元增益 (Gain of Antenna)	≥5dBi
相位中心误差 (Phase Center Error)	±2mm
低噪放增益 (LNA Gain)	40±2dB
噪声系数 (Noise Figure)	≤1.5dB
输出驻波 (VSWR)	≤1.5
输入驻波 (VSWR)	≤1.5
增益平坦度 (Gain Flatness)	±1dB
输出P1dB压缩点 (Pout at 1dB Gain Compression Point)	≥0dBm
工作电压 (LNA Drain Voltage)	3.3-12VDC
工作电流 (LNA Current Consumption)	≤45mA
差分传输延迟 (delay) 差分传输延迟 (delay)	<5ns
体积 (Dimension)	148×55.5mm
射频输出接头(RF output Connector)	TNC-C-K
安装方式 (Mounting Method)	5/8-11螺纹安装
防水等级 (Waterproof Grade)	IP67
防震等级(Shockproof Grade)	IK08
工作温度 (Operating Temp.)	-40°C ~ +85°C
存储温度 (Storage Temp.)	-40°C ~ +85°C

High precision

TOPGNSS^R

Professional GNSS wireless solutions provider

Model : TOP106

GNSS Antenna

采用GNSS板卡GNSS模式接收效果 Receiving effect of GNSS mode using GNSS board

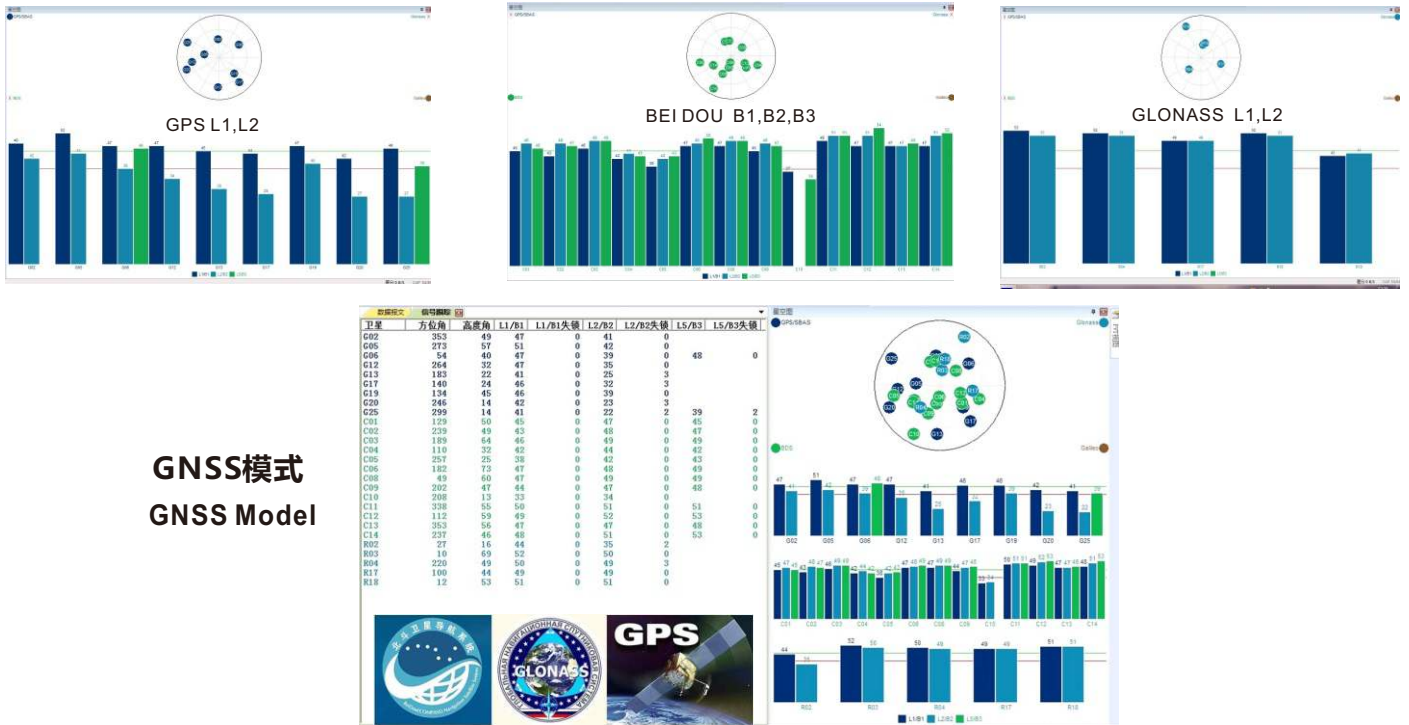

天线尺寸结构图(单位:mm) Antenna size structure (unit: mm)

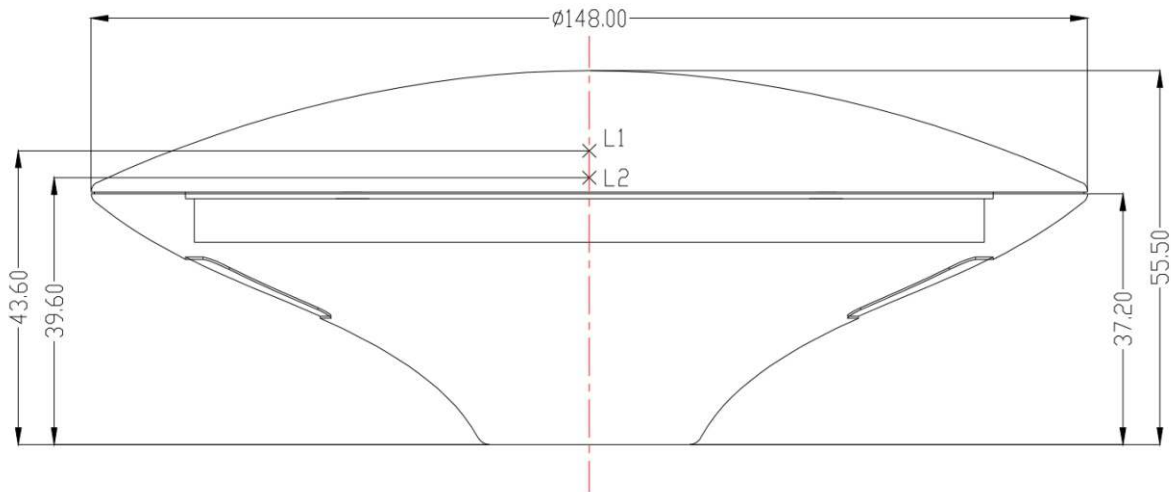

未注尺寸公差±0.2

TOPGNSS Team has a professional antenna design and research and development experience accumulated, can provide customized services for special antennas, If you have special needs, please contact us!

sales@stotoncn.com Skype:topgnss