

THIS DRAWING IS UNPUBLISHED. RELEASED FOR PUBLICATION
 © COPYRIGHT - TE Connectivity Ltd. ALL RIGHTS RESERVED.

REVISIONS					
P	LTR	DESCRIPTION	DATE	DWN	APVD
	D	REVISED PER 0720-0937-96	30MAY96	-	MJS
	D1	REVISED PER ECO-17-008806	22FEB2018	RS	DR

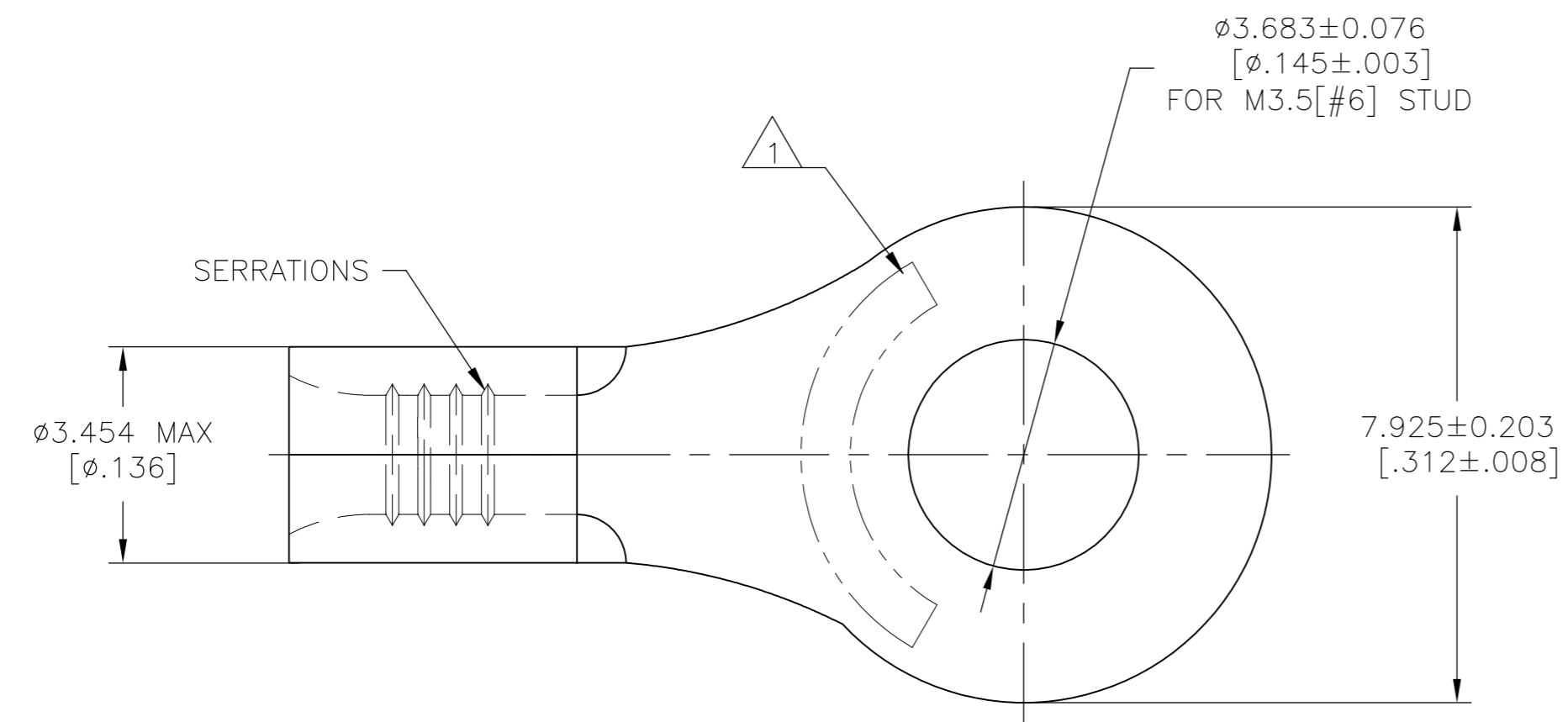

AMP WIRE RANGE	E13288 Listed
22-16 AWG STRANDED	22-16 AWG STRANDED
LR7189 Certified	MILITARY P/N AND CLASS
NOT CERTIFIED	NOT APPLICABLE

1 STAMP AMP 22-18* APPROX AS SHOWN
 22-16 TERMINALS ARE STAMPED 22-18 IN
 ACCORDANCE WITH MILITARY SPECIFICATION
 SAE AS 7928 COMMERCIAL WIRE RANGE IS
 22-16

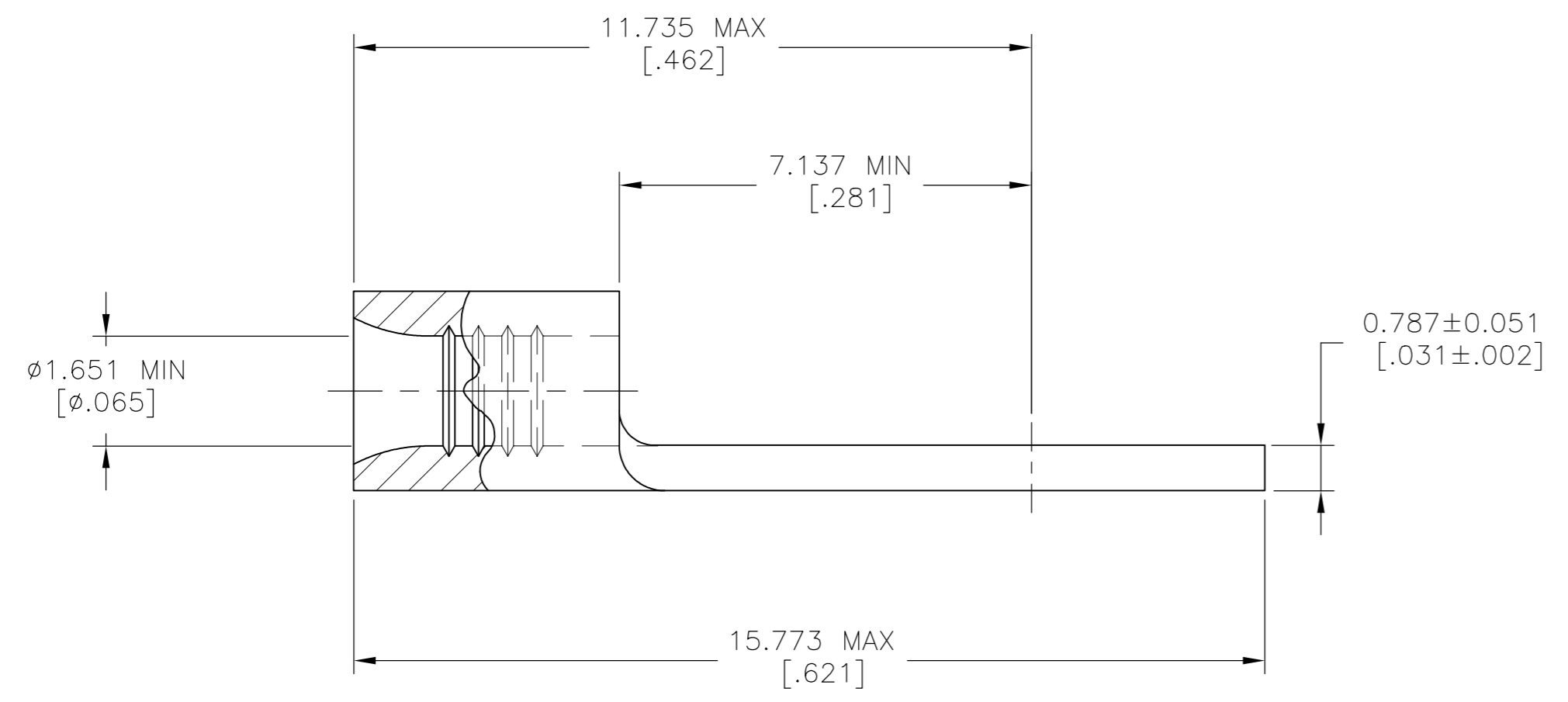

1000	LOOSE PIECE	30691
QUANTITY	PACKAGING TYPE	PART NO

AMP INCORPORATED CUSTOMER SERVICE SYSTEMS		THIS DRAWING IS A CONTROLLED DOCUMENT.		DWN RAVI S 22FEB2018	TE Connectivity Ltd.
FOR ADDITIONAL PRODUCT INFORMATION OR COPIES OF DRAWINGS AND TECHNICAL DOCUMENTS	PRODUCT INFORMATION CENTER 1-800-522-6752	MAX RECOMMENDED OPERATING TEMPERATURE: 170°C [338°F] MAX	DIMENSIONS: mm [INCHES]	CHK ROHDE DANIEL F 22FEB2018	
FOR APPLICATION	TOOLING ASSISTANCE CENTER 1-800-722-1111	VOLTAGE RATING: NOT APPLICABLE	TOLERANCES UNLESS OTHERWISE SPECIFIED:	APVD ROHDE DANIEL F 22FEB2018	NAME TERMINAL, RING TONGUE, BUDGET
TOOLING INFORMATION	1-800-722-1111	WIRE CROSS SECTIONAL AREA RANGE, 0.26-1.65mm²[509-3,260] CIR MILS STRANDED	0 PLC ± - 1 PLC ± - 2 PLC ± - 3 PLC ± 0.127[.005] 4 PLC ± - ANGLES ± -	PRODUCT SPEC UL 486 A-B	RESTRICTED TO
FOR ORDER ENTRY	1-800-526-5142	MATERIAL COPPER PER ASTM B-152 ANNEALED	FINISH TIN PLATE 0.00254[.000100] MIN THK PER ASTM B545	APPLICATION SPEC -	SIZE A2
				WEIGHT	CAGE CODE 00779
				CUSTOMER DRAWING	DRAWING NO 30691
				SCALE 10:1	SHEET 1 of 1
				REV D1	