

This document is the property of Amphenol Corporation and is delivered on the express condition that it is not to be disclosed, reproduced or used, in whole or in part, for manufacture or sale by anyone other than Amphenol Corporation without its prior consent, & that no right is granted to disclose or to use any information in this document.

CUSTOMER DRAWING

REVISIONS				
SYM	ECN	DESCRIPTION	DATE	APPROVED
A	HKXXXX	NEW RELEASE	2021/11/12	Michael.qin

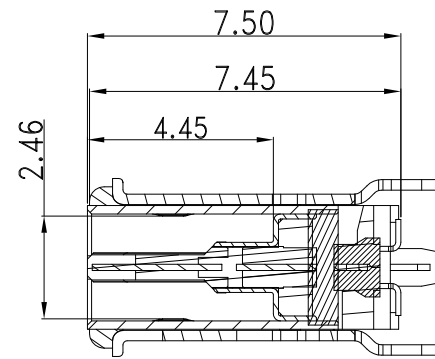
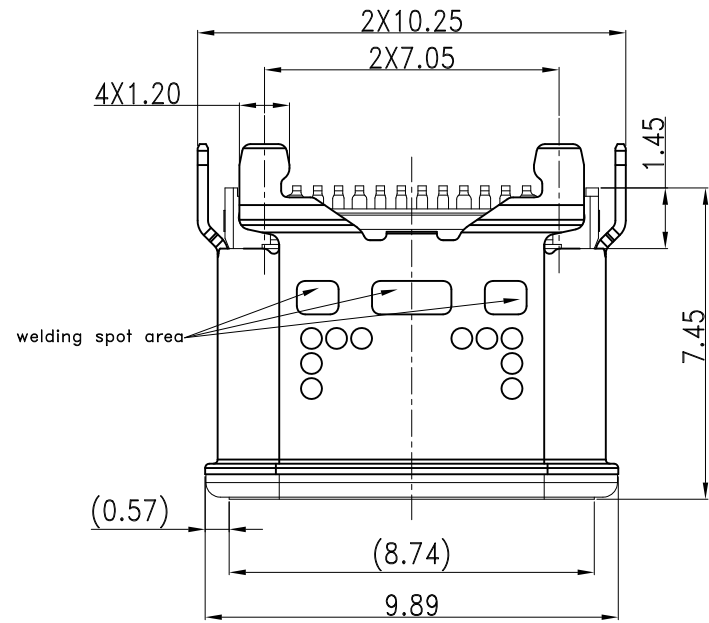

SECTION A-A(剖视图A-A)
SCALE 1:1 (比例 1:1)



Pin No	Signal Name	Mating Sequence	Pin No	Signal Name	Mating Sequence
A1	GND	First	B12	GND	First
A2	TX1+	Second	B11	RX1+	Second
A3	TX1-	Second	B10	RX1-	Second
A4	Vbus	First	B9	Vbus	First
A5	CC1	Second	B8	SBU2	Second
A6	D+	Second	B7	D-	Second
A7	D-	Second	B6	D+	Second
A8	SBU1	Second	B5	CC2	Second
A9	Vbus	First	B4	Vbus	First
A10	RX2-	Second	B3	TX2-	Second
A11	RX2+	Second	B2	TX2+	Second
A12	GND	First	B1	GND	First
SHELL	GND		SHELL	GND	

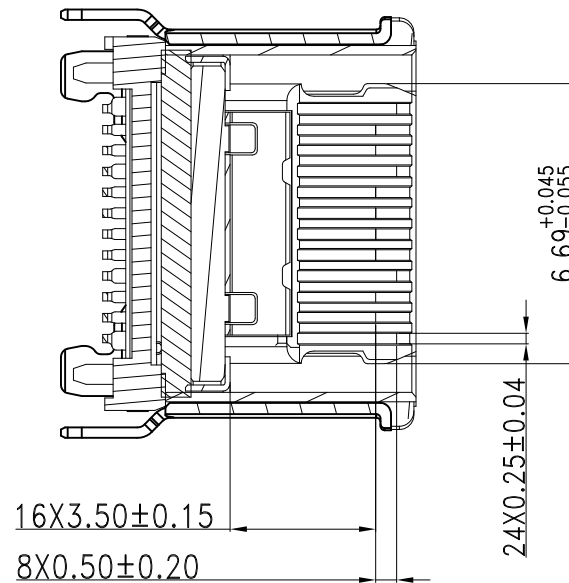
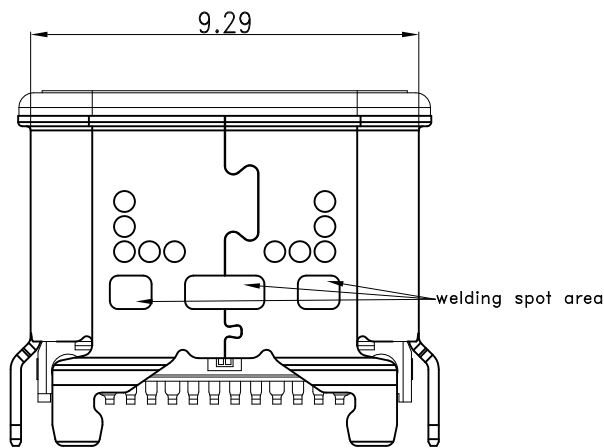
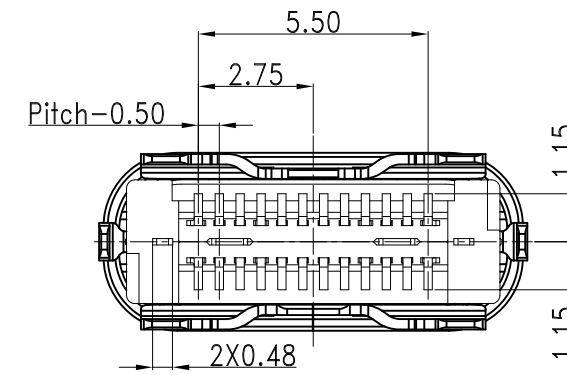
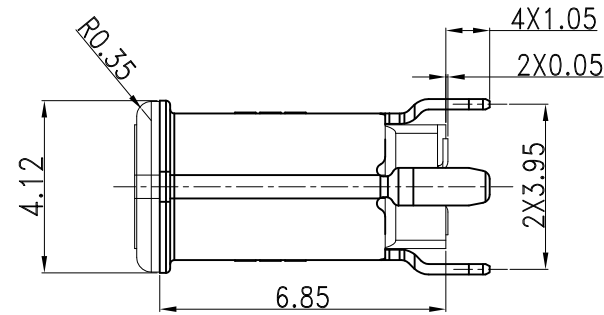
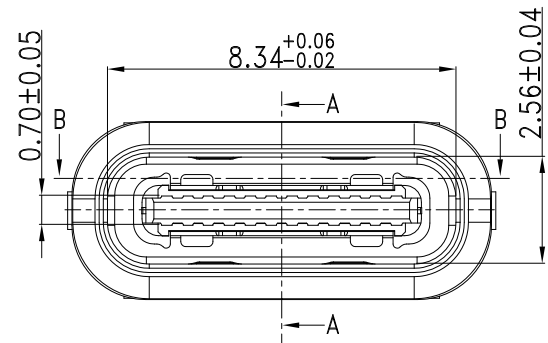

HF(无卤)	√
Non-HF(有卤)	

UNLESS OTHERWISE SPECIFIED TOLERANCES	APPROVAL	DATE	Amphenol Amphenol East Asia Limited
	DRAWN Alec.li	11-12/21	
.X +/- 0.50 .XX +/- 0.25 .XXX +/- 0.10 FRACTIONS +/- ANGLES +/- 3°	CHECKED Michael.qin	11-12/21	TITLE USB Type C socket connector, Vertical, Double SMT type, Water proof IPX8
	CHECKED		
FOR MATERIALS AND FINISHES SEE NOTES	DRAWING FILE : R:\DCI\Engineering data\RD\I.T. 工程图客户图		SIZE DRAWING NO. A3 C 12402082
REMOVE SHARP EDGES	ANGLE OF PROJECTION		REV. A
DIMENSIONS	U.S. INCHES (METRIC) (MM)		SCALE NONE SHEET 1 OF 2

This document is the property of Amphenol Corporation and is delivered on the express condition that it is not to be disclosed, reproduced or used, in whole or in part, for manufacture or sale by anyone other than Amphenol Corporation without its prior consent, & that no right is granted to disclose or to use any information in this document.

CUSTOMER DRAWING

REVISIONS				
SYM	ECN	DESCRIPTION	DATE	APPROVED
See page 1				

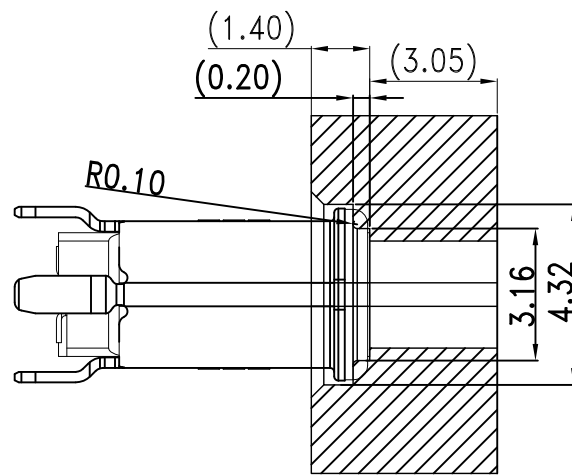
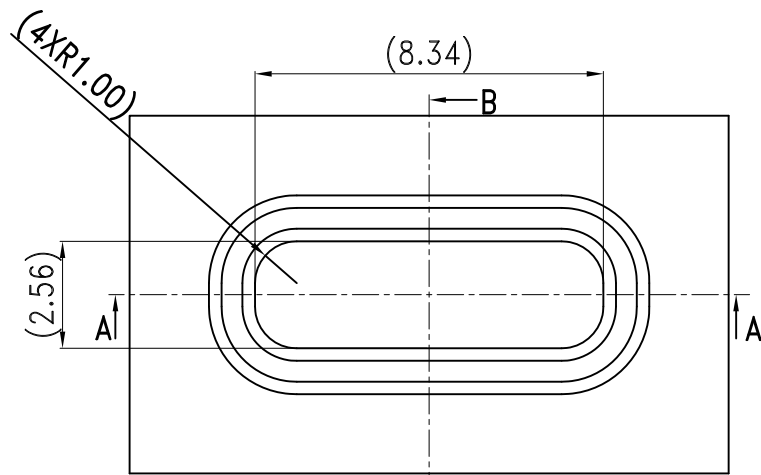

SEC A-A

Recommended Case/推荐的外壳布局
General Tolerances: ±0.05/一般公差: ±0.05

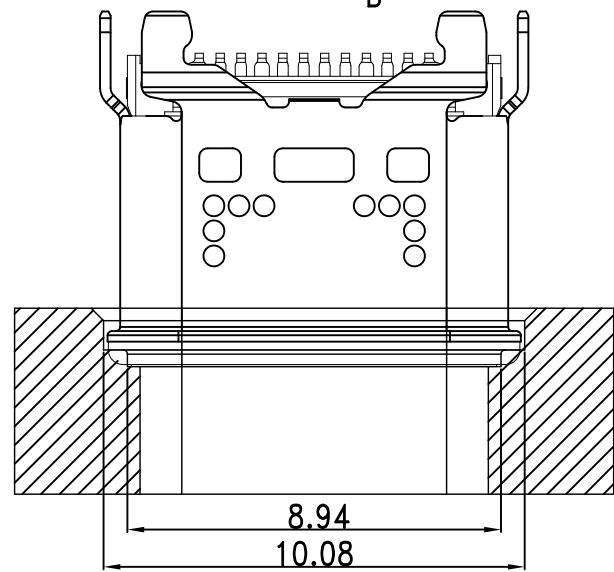

SEC B-B

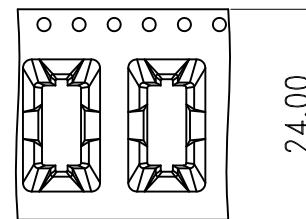
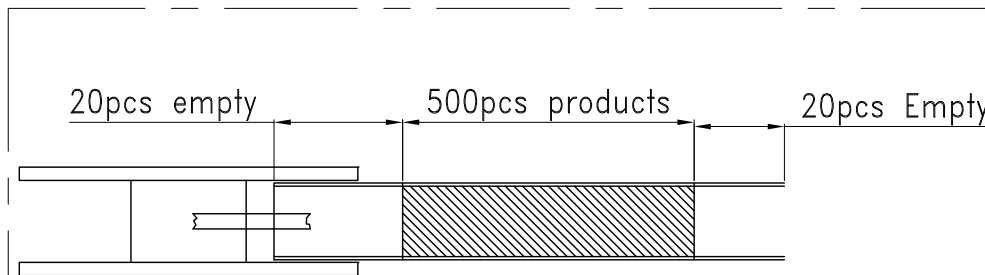

customer unwinding direction

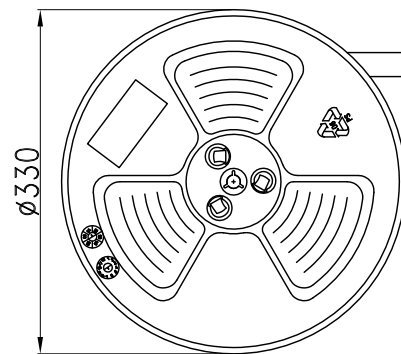

PACK DIRECTION

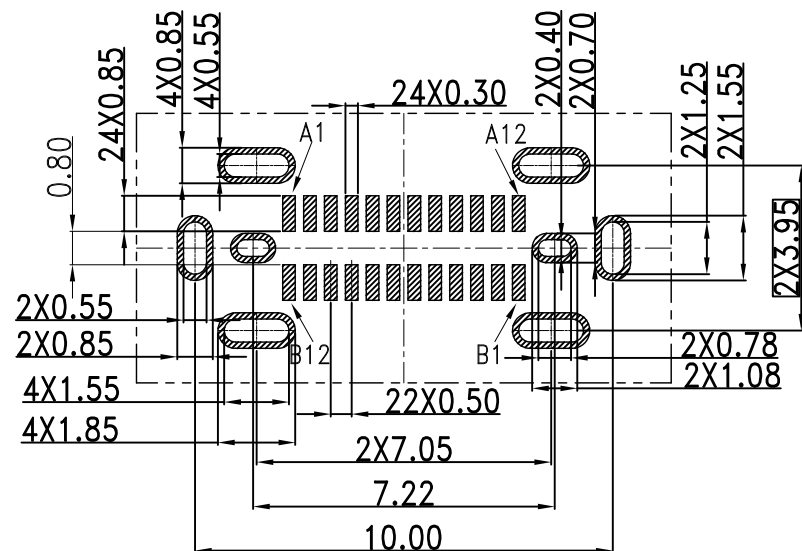

Recommended PCB Layout(Top View)/推荐的PCB布局(前视图)
General Tolerances: ±0.05/一般公差: ±0.05

NOTES/注释:

- MATERIAL/材料: SEE TABLE/见下表
- GENERAL SPECIFICATION/通用特性:
 - COPLANARITY /共面度: 0.10 Max.
 - CURRENT RATING: 5A / 额定电流: 5安培
 - CONTACT RESISTANCE: 40mΩ MAX (INITIAL).
INSULATION RESISTANCE: 100MΩ Min
接触电阻: 40毫欧最大(初始值) / 绝缘电阻: 100MΩ Min
 - DIELECTRIC WITHSTANDING VOLTAGE: 100 VAC
耐电压: 100伏交流
 - MECHANICAL CHARACTERISTICS:
INSERTION FORCE: 5~20N EXTRACTION FORCE: 8~20N
AFTER DURABILITY EXTRACTION FORCE: 6~20N
力学特性: 初始插入力: 5~20N 拔出力: 8~20N
耐久后拔出力: 6~20N
 - DURABILITY: 10000 CYCLES / 耐久性: 10000次
 - PACKAGING TYPE: CARRIER TAPE./ 包装类型: 载带包装
- WATERPROOF CLASS IPX8/防水等级 IPX8
- DIMENSIONING SHALL BE INTERPRETED PER ASME Y14.5M 1994.
尺寸标注基于ASME Y14.5M 1994标准规范
- MATERIAL SHOULD BE FULFILLED AMPHENOL SPEC.# S-SN-002, FOR HALOGEN FREE PRODUCTS, ALSO NEED TO MEET S-SN-004.
产品材料环保标准为Amphenol SSN#002,如果是无卤产品需满足标准SSN#004
- ORDER P/N SYSTEM/产品料号编码系统: 12402082E512A

Plating Spec:

E5: Mating Area: Au 30u" Min
Solder Area: Gold flash
50u"Min Nickel Under Plating Over All

A: HF
Package Spec.
2: Reel
Date Code Description
0: Without D/C
1: With D/C

HF(无卤)	√
Non-HF(有卤)	

ITEM	DESCRIPTION	Q'TY	MATERIAL	
8	GAP	1	HIGH TEMPERATURE PLASTIC	BLACK
8	UV	1	GLUE	RED
7	SMALL SHELL	1	STAINLESS STEEL	NI PLATED OR CLEANING
6	MAIN SHELL	1	STAINLESS STEEL	NI PLATED OR CLEANING
5	OUTOR SHELL	1	STAINLESS STEEL	SOLDER NICKEL: 30" MIN
4	MID PLATE	1	STAINLESS STEEL	NICKEL: 30U" MIN
3	BOTTOM TERMINAL	1	COPPER ALLOY	MATING AREA : Au30u"MIN SOLDER TAIL: Gold Flash, 50u"MIN NICKEL OVERALL.
2	TOP TERMINAL	1	COPPER ALLOY	MATING AREA : Au30u"MIN SOLDER TAIL: Gold Flash, 50u"MIN NICKEL OVERALL.
1	MOLDING HOUSING	1	HIGH TEMPERATURE PLASTIC	BLACK

BILL OF MATERIAL

UNLESS OTHERWISE SPECIFIED TOLERANCES U.S. METRIC .X +/- 0.50 .XX +/- 0.25 .XXX +/- 0.10 FRACTIONS +/- ANGLES +/- 3'	APPROVAL	DATE	Amphenol Amphenol East Asia Limited
	DRAWN Alec.ii	11-12/21	
FOR MATERIALS AND FINISHES SEE NOTES	CHECKED Michael.qin	11-12/21	TITLE USB Type C socket connector, Vertical, Double SMT type, Water proof IPX8
REMOVE SHARP EDGES	DRAWING FILE : R:\DCI\Engineering\data\RD\T.程图客户版		SIZE DRAWING NO. A3 C 12402082
DIMENSIONS	ANGLE OF PROJECTION		REV. A
U.S. INCHES (METRIC) (MM)	SCALE NONE		SHEET 2 OF 2

Packing:
1. 500 Pcs/Reel.
2. 10 Reels/Carton.