

HF/VHF/UHF RF power N-channel MOSFET

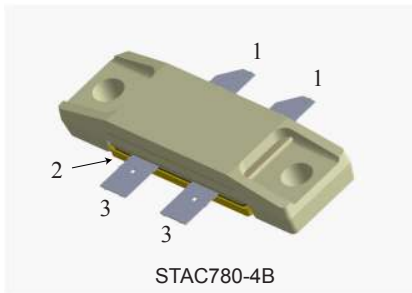

Pin connection

Pin	Connection
1	Drain
2	Source (bottom side)
3	Gate

Features

Order code	Frequency	V _{DD}	P _{OUT}	Gain	Efficiency
STAC3932B	123 MHz	100 V	580 W	24.6 dB	70 %

- Excellent thermal stability
- Common source push-pull configuration
- P_{OUT} = 580 W typ. with 24.6 dB gain at 123 MHz
- In compliance with the 2002/95/EC European directive
- ST air-cavity STAC packaging technology

Description

The STAC3932B is an N-channel MOS field-effect RF power transistor. It is intended for use in 100 V DC large signal applications up to 250 MHz.



Product status

STAC3932B

Product summary

Order code	STAC3932B
Marking	STAC3932
Package	STAC780-4B
Packing	Box
Base / Bulk qty	20 / 80

1 Electrical data

1.1 Maximum ratings

Table 1. Absolute maximum ratings (T_{CASE} = 25 °C)

Symbol	Parameter	Value	Unit
V _{(BR)DSS} ⁽¹⁾	Drain source voltage	250	V
V _{DGR}	Drain-gate voltage (R _{GS} = 1 MΩ)	250	V
V _{GS}	Gate-source voltage	±20	V
I _D	Drain current	20	A
P _{DISS}	Power dissipation	625	W
T _J	Maximum operating junction temperature	200	°C
T _{STG}	Storage temperature range	-65 to +150	°C

1. T_J = 150 °C

1.2 Thermal data

Table 2. Thermal data

Symbol	Parameter	Value	Unit
R _{thJC}	Junction - case thermal resistance	0.28	°C/W

1.3 ESD protection characteristics

Table 3. ESD protection

Symbol	Test Methodology	Class
HBM	Human Body Model (per JESD22-A114)	2

2 Electrical characteristics

$T_{CASE} = +25\text{ °C}$ (unless otherwise specified)

2.1 Static

Table 4. Static

Symbol	Parameter	Test conditions	Min.	Typ.	Max.	Unit
$V_{(BR)DSS}$	Drain - Source Breakdown voltage	$V_{GS} = 0\text{ V}$, $I_{DS} = 100\text{ mA}$, $T_J = 150\text{ °C}$	250			V
I_{DSS}	Zero gate voltage drain leakage current	$V_{GS} = 0\text{ V}$, $V_{DS} = 100\text{ V}$			1	mA
I_{GSS}	Gate - Source leakage current	$V_{GS} = 20\text{ V}$, $V_{DS} = 0\text{ V}$			250	nA
$V_{DS(ON)}$	Drain - Source on voltage	$V_{GS} = 10\text{ V}$, $I_D = 5\text{ A}$		2.5	3.5	V
V_{TH}	Gate - Source threshold voltage	$I_{DS} = 250\text{ mA}$	2.0		4.0	V
G_{FS}	Forward transconductance	$V_{DS} = 10\text{ V}$, $I_D = 2.5\text{ A}$	3.0		5.0	S
C_{ISS}	Input capacitance	$V_{GS} = 0\text{ V}$, $V_{DS} = 100\text{ V}$, $f = 1\text{ MHz}$		492		pF
C_{OSS}	Output capacitance			134		pF
C_{RSS}	Reverse transfer capacitance			5.2		pF

2.2 Dynamic

Table 5. Dynamic ⁽¹⁾

Symbol	Parameter	Test conditions	Min.	Typ.	Max.	Unit
P_{OUT}	Output power	CW, $P_{IN} = 2\text{ W}$	450	580	-	W
P_{OUT}	Output power	Pulse PW = 1 ms, DC = 10 % , $P_{IN} = 8\text{ W}$		900	-	W
η_D	Drain efficiency	CW, $P_{IN} = 2\text{ W}$		70	-	%
η_D	Drain efficiency	Pulse PW = 1 ms, DC = 10 % , $P_{IN} = 8\text{ W}$		65	-	%

1. $V_{DD} = 100\text{ V}$, $I_{DQ} = 2 \times 250\text{ mA}$, $f = 123\text{ MHz}$

3 Impedances

Figure 1. Impedance data

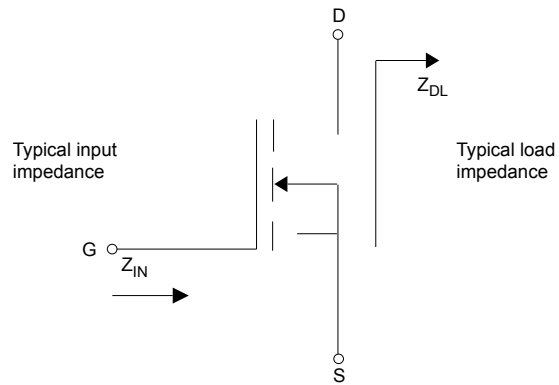

Note: Measured gate-to-gate and drain-to-drain, respectively (balanced configuration).

Table 6. Impedance data

Frequency	$Z_{IN} (\Omega)$	$Z_{DL} (\Omega)$
123 MHz (pulse)	1.0 - j 4.80	6.3 + j 10.5
123 MHz (CW)	0.8 - j 3.45	5.0 + j 13.0
64 MHz (pulse)	1.4 - j 10.0	12.8 + j 14.0

4 Typical performance

Figure 2. Capacitances vs drain supply voltage

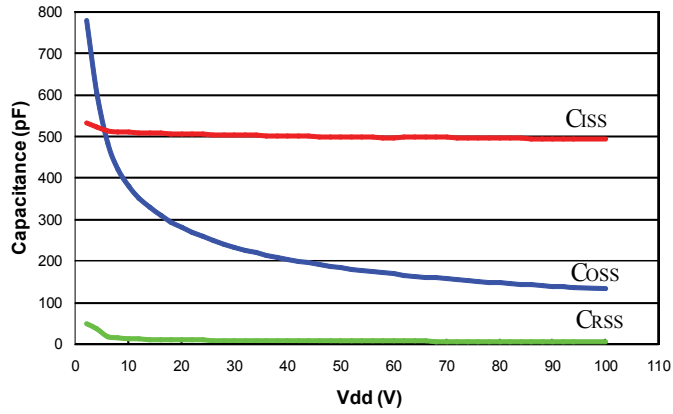

AM0110 6v1

Figure 3. Safe operating area

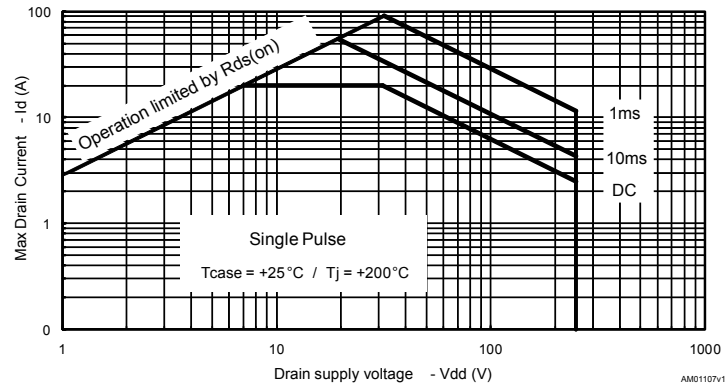

AM01107v1

Figure 4. Transient thermal impedance

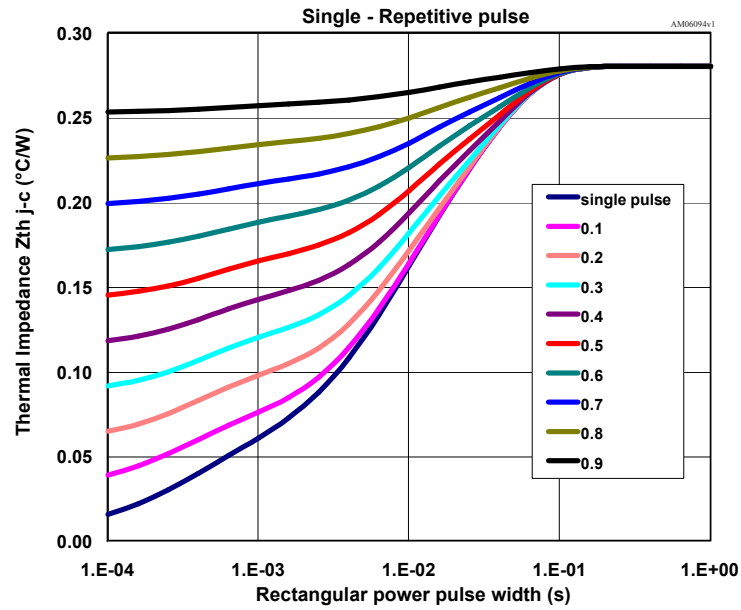
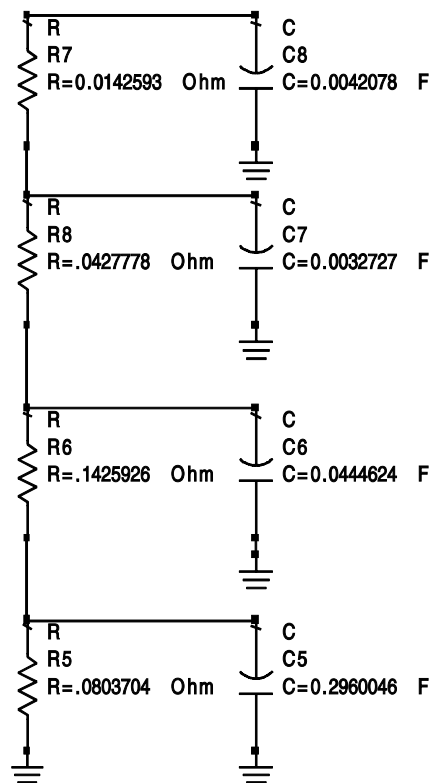
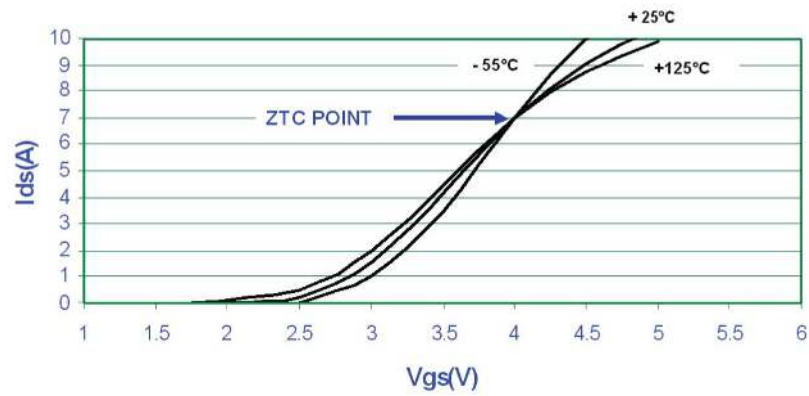

Figure 5. Transient thermal model



AM06106V1

Figure 6. Zero temperature coefficient point



AM01108v1

Figure 7. Output power and efficiency vs input power (CW)

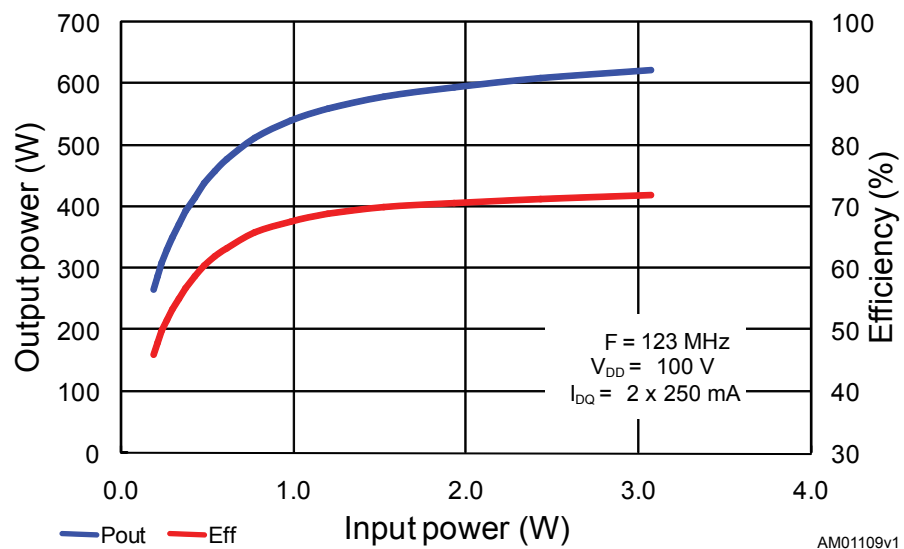

AM01109v1

Figure 8. Gain vs output power (CW)

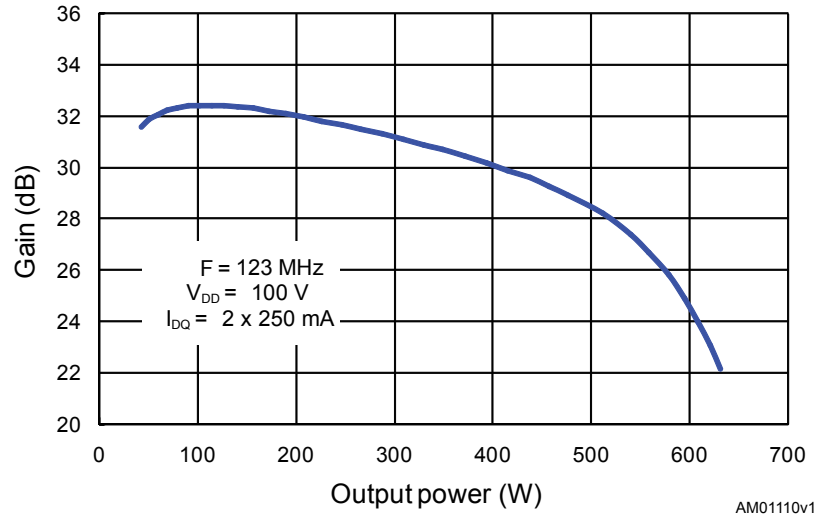
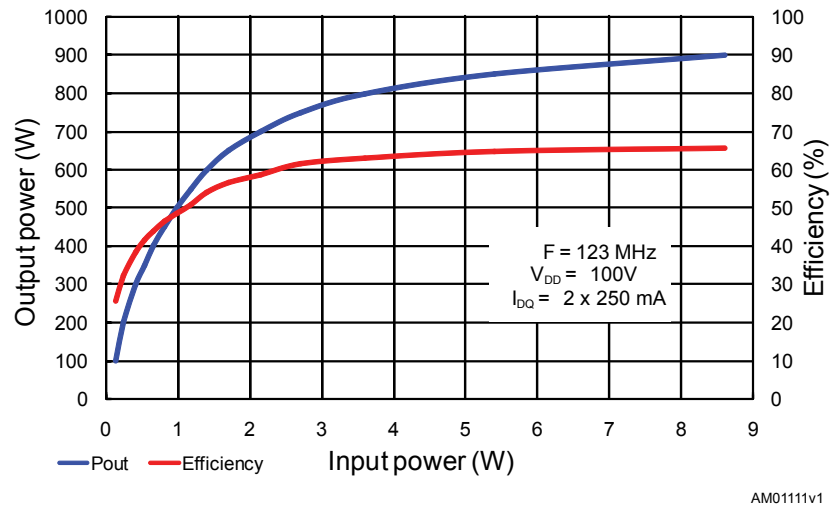

Figure 9. Output power and efficiency vs input power (PW = 1 ms, DC = 10%)



5 Test circuit

5.1 Electrical schematic and BOM

Figure 10. Electrical schematic

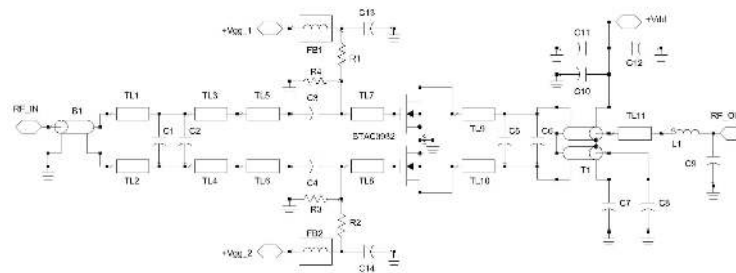

AMD1103v1

Table 7. Bill of materials

Component	Description
C1	270 pF ATC 100B chip capacitor
C2	180 pF ATC 100B chip capacitor
C3, C4	750 pF ATC 700B chip capacitor
C5, C8	43 pF ATC 100B chip capacitor
C6	20 pF ATC 100B chip capacitor
C7	1000 pF ATC 100C chip capacitor
C9	5.6 pF ATC 100B chip capacitor
C10	2200 pF ATC 100C chip capacitor
C11	470 pF ATC 100B chip capacitor
C12	100 μ F, 200 V electrolytic capacitor
C13, C14	1200 pF ATC 700B chip capacitor
R1, R2	15 Ω 1/4 W chip resistor
R3, R4	30 Ω 1/4 W axial lead resistor
L1	3 turns, 16 ga magnet wire, Id 3/8", .165" turn spacing, 78 nH
FB1, FB2	ferrite bead, Fair-Rite # 2743019447
B1	1/4 λ balun transformer, RG316-25 Ω , 16.5"
T1	20 ga teflon coated wire thru 4 copper tubes OD 1/8"x 1.5"
TL1, TL2	0.740" x 0.200" microstrip
TL3, TL4	0.360" x 0.200" microstrip
TL5, TL6	0.480" x 0.350" microstrip
TL7, TL8	0.220" x 0.350" microstrip
TL9, TL10	0.350" x 0.660" microstrip
TL11	0.415" x 0.200" microstrip
Board	0.062" FR-4

5.2 Board and layout

Figure 11. Test circuit PCB photo

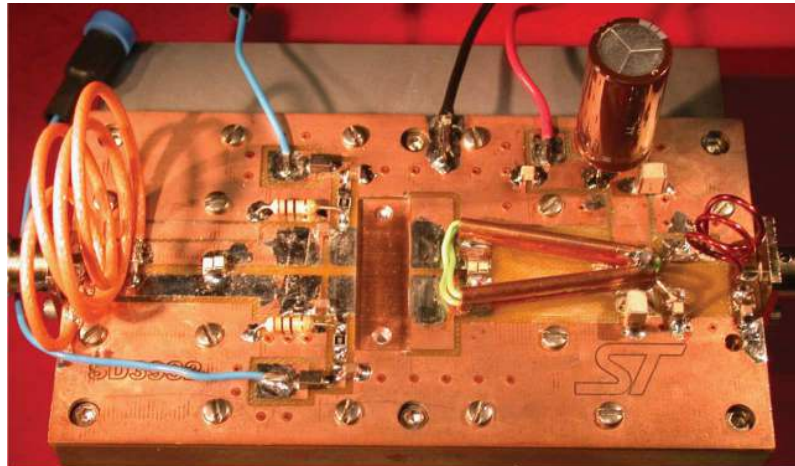

AM01104v1

Figure 12. Test circuit layout

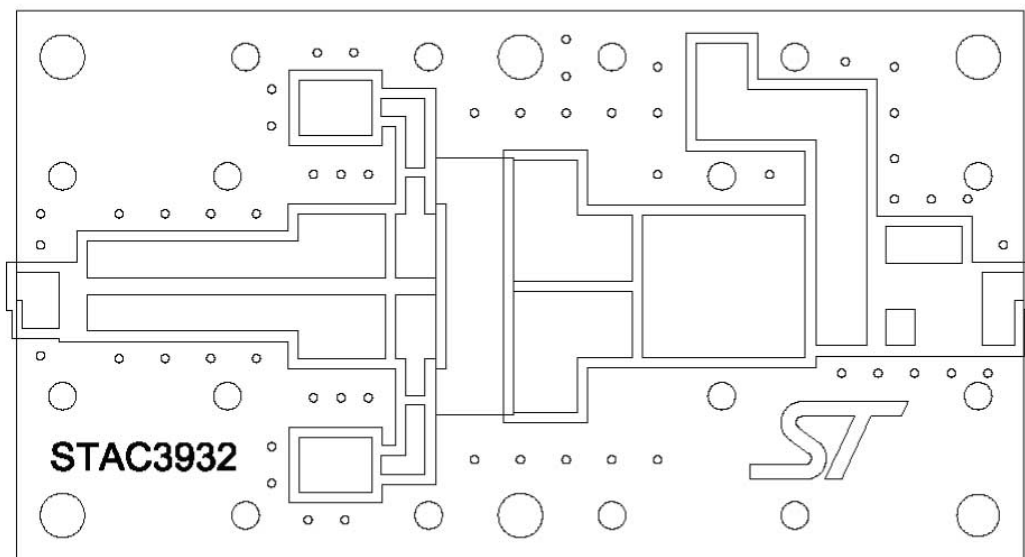

AM01105 v1

6 Package information

In order to meet environmental requirements, ST offers these devices in different grades of **ECOPACK** packages, depending on their level of environmental compliance. ECOPACK specifications, grade definitions and product status are available at: www.st.com. ECOPACK is an ST trademark.

6.1 STAC780-4B package information

Figure 13. STAC780-4B package outline

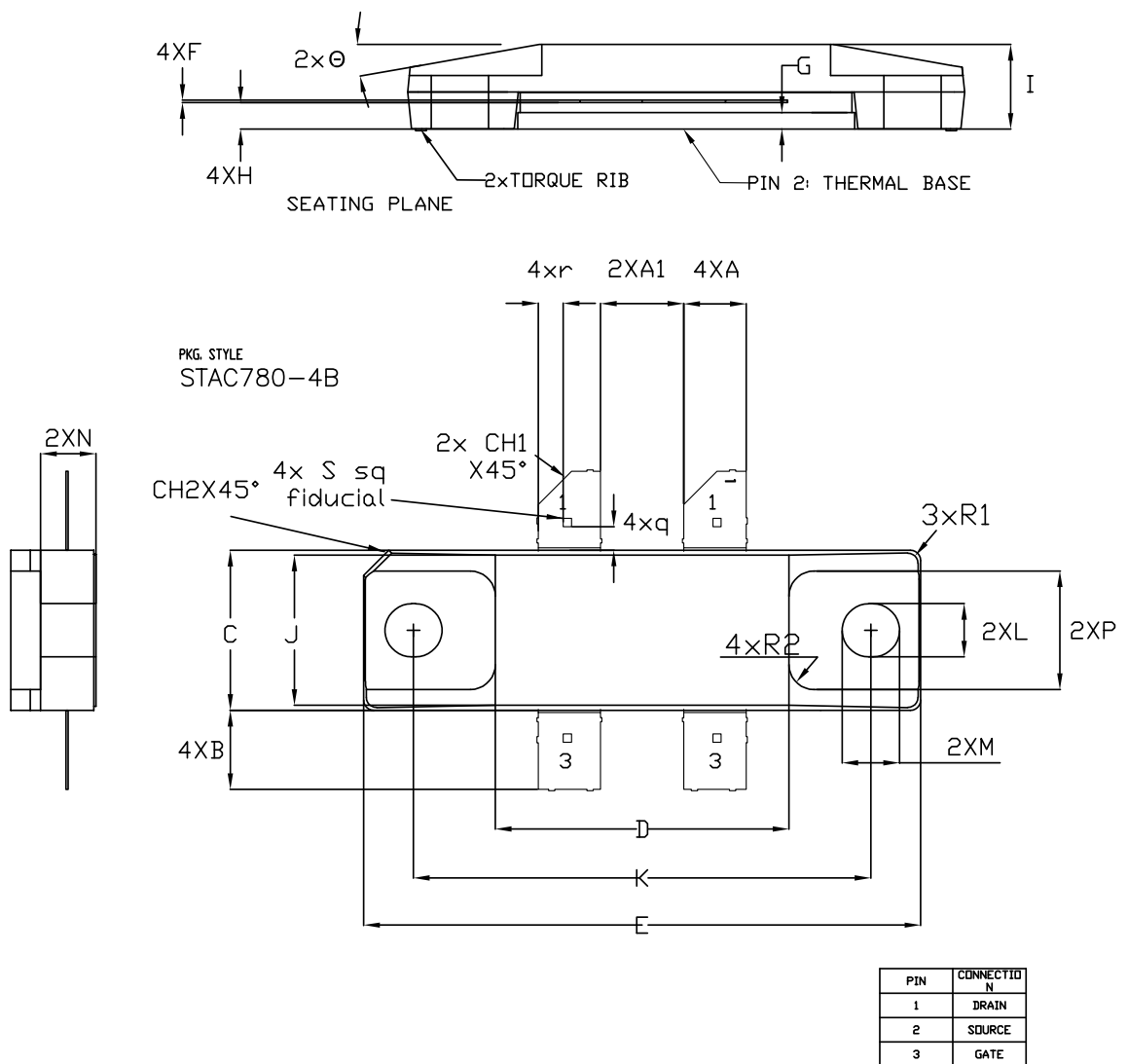

DM00481937 rev.2

Table 8. STAC780-4B mechanical data

Symbol	Millimeters		
	Min	Typ	Max
A	3.76		3.86
A1	5.03		5.13
B	4.57		5.08
C	9.65		9.91
D	17.78		18.08
E	33.88		34.19
F	0.13		0.18
G	0.97		1.14
H	1.52		1.70
I	4.83		5.33
J	9.52		9.78
K	27.69		28.19
L	3.20	3.25	3.30
M	3.43	3.51	3.58
M	3.30	3.38	3.45
p	7.14	7.21	7.29
q		1.45	
R1		0.64	
R2		1.52	
r		1.52	
s		0.51	
Θ		10°	
CH1		2.03	
CH2		1.52	

6.2 Marking information

PACKAGE FACE : TOP

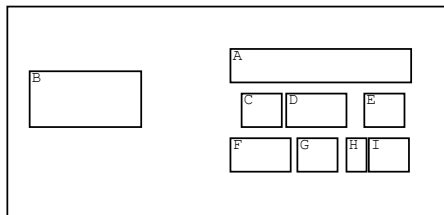

LEGEND

- Marking Composition Field
- A - MARKING AREA
 - B - ST LOGO
 - C - Assy Plant
(PP)
 - D - BE Sequence
(LLL)
 - E - Diffusion Traceability Plant
(WX)
 - F - COUNTRY OF ORIGIN
(MAX CHAR ALLOWED = 3)
 - G - Test & Finishing Plant
(TF)
 - H - Assy Year
(Y)
 - I - Assy Week
(WW)

Revision history

Table 9. Document revision history

Date	Revision	Changes
06-Mar-2009	1	First release.
18-Feb-2010	2	Updated description on cover page.
16-Mar-2010	3	Updated Figure 7: Maximum safe operating area. Added Figure 8: Transient thermal impedance. and Figure 9: Transient thermal model.
06-Jul-2011	4	Updated Chapter 7: Package mechanical data. Added Chapter 8: Marking, packing and shipping specifications.
22-Sep-2011	5	Update values for L and M in Table 9: STAC244B mechanical data.
01-Jul-2013	6	Modified pin labeling in Figure 1: Pin connection. Minor text corrections throughout document.
03-Apr-2020	7	Updated package information. Added <i>Section 1.3 ESD protection characteristics</i> .
14-Jul-2020	8	Modified Table 4. Static .

Contents

1	Electrical data	2
1.1	Maximum ratings	2
1.2	Thermal data	2
1.3	ESD protection characteristics	2
2	Electrical characteristics	3
2.1	Static	3
2.2	Dynamic	3
3	Impedances	4
4	Typical performance	5
5	Test circuit	9
5.1	Electrical schematic and BOM	9
5.2	Board and layout	10
6	Package information	11
6.1	STAC780-4B package information	11
6.2	Marking information	13
	Revision history	14

IMPORTANT NOTICE – PLEASE READ CAREFULLY

STMicroelectronics NV and its subsidiaries (“ST”) reserve the right to make changes, corrections, enhancements, modifications, and improvements to ST products and/or to this document at any time without notice. Purchasers should obtain the latest relevant information on ST products before placing orders. ST products are sold pursuant to ST’s terms and conditions of sale in place at the time of order acknowledgement.

Purchasers are solely responsible for the choice, selection, and use of ST products and ST assumes no liability for application assistance or the design of Purchasers’ products.

No license, express or implied, to any intellectual property right is granted by ST herein.

Resale of ST products with provisions different from the information set forth herein shall void any warranty granted by ST for such product.

ST and the ST logo are trademarks of ST. For additional information about ST trademarks, please refer to www.st.com/trademarks. All other product or service names are the property of their respective owners.

Information in this document supersedes and replaces information previously supplied in any prior versions of this document.

© 2020 STMicroelectronics – All rights reserved