

Tous droits strictement reserves. Reproduction ou communication a des tiers interdite sous quelque forme que ce soit sans autorisation écrite du propriétaire. Propriete de c FCI. Droits de reproduction FCI.

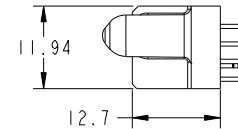

All rights strictly reserved. Reproduction or issue to third parties in any form whatever is not permitted without written authority from the proprietor. Property of FCI. Copyright FCI.

PRODUCT NO.	POWER						
	E2	P5	P4	P3	P2	P1	E1
51940-339-- NOTE: 3							

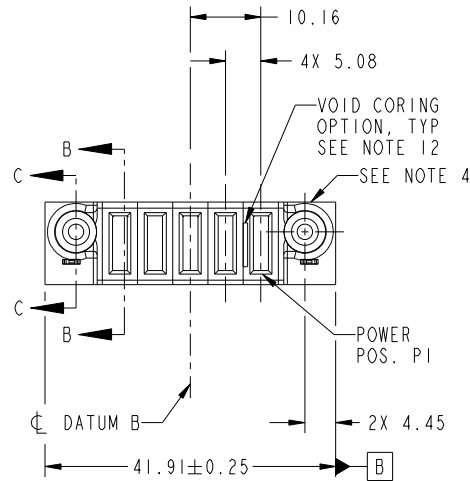

CODE	DIM "M" MATING LENGTH	CONTACT TYPE
PD	[2.34]	POWER
HA	[N/A]	HOLD-DOWN
PA	[1.07]	POWER
X	OMITTED	

mat'l code				SEE NOTES		tolerances unless otherwise specified		CUSTOMER		FCI	
ltr	ecn no.	dr	date	linear	0.X ±0.5	projection		COPY		www.fciconnect.com	
A	DG10-0087	WD	03/02/10	angles	0.XX ±0.25			title		5P	
				dr	0.XXX ±0.1			product family		PwrBlade	
				enr	0° ±2°	scale		size		code	
				chr	Warren Du 03/01/10	1:1		dwg no		213	
				appd	Warren Du 03/01/10			51940-339		sheet	
					PM ZHENG 03/01/10			A		1 of 4	
					Joseph Hsia 03/01/10						
sheet index	revision sheet	A	A	A	A						
		1	2	3	4						

cage code 22526

Pro/E

Tous droits strictement reserves. Reproduction ou communication a des tiers interdite sous quelque forme que ce soit sans autorisation écrite du propriétaire. Propriete de c FCI. Droits de reproduction FCI.



All rights strictly reserved. Reproduction or issue to third parties in any form whatever is not permitted without written authority from the proprietor. Property of FCI. Copyright FCI.

PRODUCT NUMBER
51940-339_
NOTE: 3

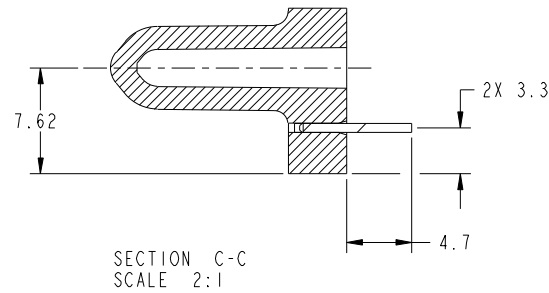
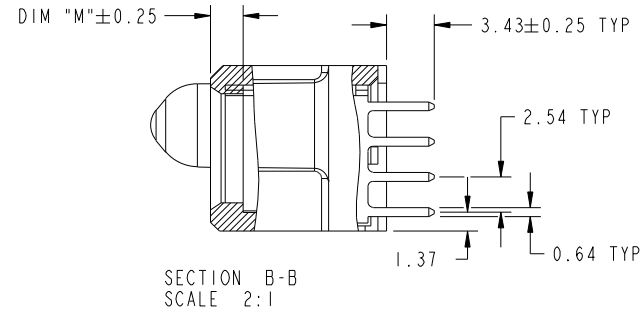

mat'l code				tolerances unless otherwise specified		CUSTOMER		FCI	
ltr	ecr no.	dr	date	linear	0.X ±0.5	COPY		www.fciconnect.com	
A				linear	0.XX ±0.25	projection		title	
				angles	0.XXX ±0.1			5P VERTICAL SOLDER RECEPT	
				dr	0° ±2°			product family PwrBlade code	
				enr	Warren Du 03/01/10	scale		size	
				chr	Warren Du 03/01/10	1:1		dwg no	
				appd	PM ZHENG 03/01/10			51940-339	
					Joseph Hsia 03/01/10			sheet	
sheet index		revision sheet						2 of 4	

cage code 22526

Pro/E

Tous droits strictement reserves. Reproduction ou communication a des tiers interdite sous quelque forme que ce soit sans autorisation écrite du propriétaire. Propriete de c FCI. Droits de reproduction FCI.

All rights strictly reserved. Reproduction or issue to third parties in any form whatever is not permitted without written authority from the proprietor. Property of FCI. Copyright FCI.



PRODUCT NUMBER
51940-339__
NOTE: 3

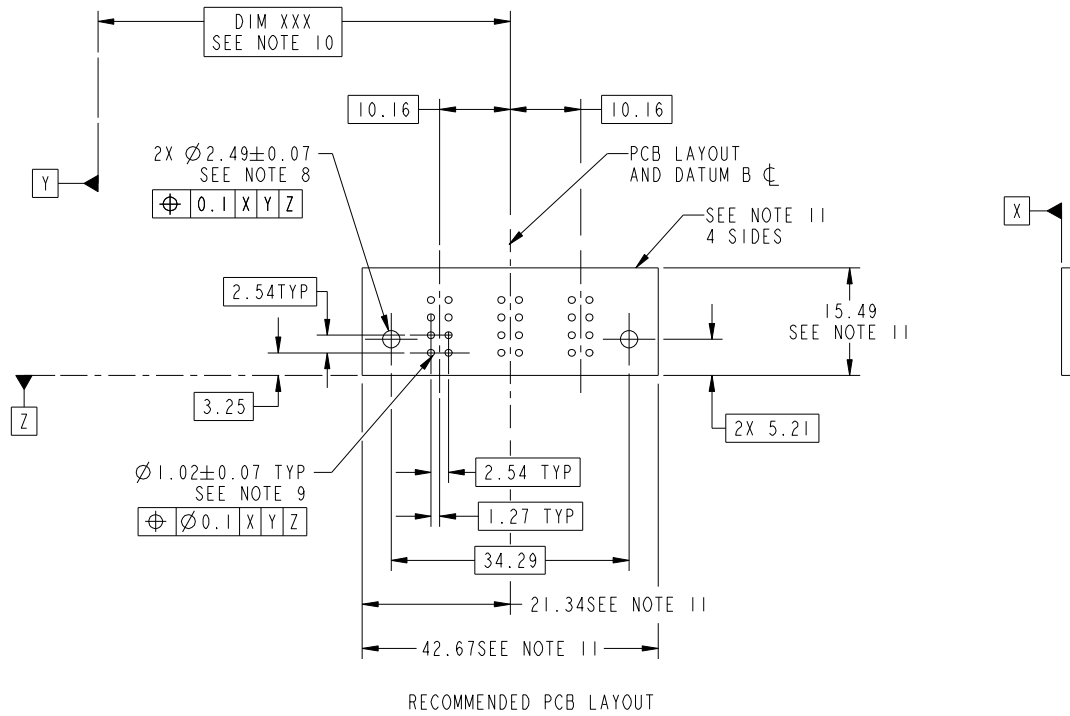

mat'l code				tolerances unless otherwise specified		CUSTOMER		FCI	
ltr	ecn no.	dr	date	linear	0.X ± 0.5	COPY		www.fciconnect.com	
A				linear	0.XX ± 0.25	projection	title 5P VERTICAL SOLDER RECEPT		
				angles	0.XXX ± 0.1			product family PwrBlade code 213	
				dr	Warren Du 03/01/10	MIM		size	dwg no 51940-339
				enr	Warren Du 03/01/10			scale	sheet 3 of 4
				chr	PM ZHENG 03/01/10	1:1		cage code 22526	
				appd	Joseph Hsia 03/01/10				
sheet index	revision sheet								

Pro/E

Tous droits strictement reserves. Reproduction ou communication a des tiers interdite sous quelque forme que ce soit sans autorisation écrite du propriétaire. Propriete de c FCI. Droits de reproduction FCI.



All rights strictly reserved. Reproduction or issue to third parties in any form whatever is not permitted without written authority from the proprietor. Property of FCI. Copyright FCI.

PRODUCT NUMBER
51940-339_
NOTE: 3

NOTES:

1. DIMENSIONS AND TOLERANCES ARE IN ACCORDANCE WITH ASME Y14.5M, 1994 UNLESS OTHERWISE SPECIFIED.

CONNECTOR NOTES:

- 2 HOUSING MATERIAL: UL 94 V-0 GLASS FILLED HIGH-TEMP THERMOPLASTIC
POWER CONTACT MATERIAL: COPPER ALLOY
SIGNAL PIN MATERIAL: COPPER ALLOY
 - 3. SEE ITEM 5 & 6 IN PRINT 10064183 FOR PLATING SPEC OF 51940-339 AND 51940-339LF RESPECTIVELY.
 - 4 MANUFACTURER'S NAME, DATE CODE AND OPTIONAL P/N TO APPEAR ON THIS SURFACE. THE P/N CAN BE OMITTED IF THERE IS NOT ENOUGH SPACE ON THIS SURFACE.
 - 5. PRODUCT SPECIFICATION GS-12-149.
APPLICATION SPECIFICATION BUS-20-067.
 - 6. PACKAGED IN TRAYS.
- PCB NOTES:
- 7. ALL HOLE DIAMETERS ARE FINISHED HOLE SIZE.
 - 8 MOUNTING HOLES, WHERE APPLICABLE, ARE UNPLATED.
 - 9 $\varnothing 1.151 \pm 0.025$ DRILLED HOLES PLATED WITH
0.008 MIN SnPb OR Sn OVER 0.03
TO 0.08 Cu PLATING TO ACHIEVE
 $\varnothing 1.02 \pm 0.07$ HOLE.
 - 10 "DIM XXX" TO BE DETERMINED BY THE CUSTOMER.
 - 11 CONNECTOR KEEP-OUT ZONE.
 - 12. THE VOID CORING IN BETWEEN POWER MODULES, SIGNAL MODULES AND END MODULES ARE OPTIONAL AND THE SHAPE MAY BE DIFFERENT FOR OPTIMIZE THE MOLDING PROCESS. THE VOID CORING WILL NOT EFFECT TO PRODUCT FUNCTION.

mat'l code				tolerances unless otherwise specified		CUSTOMER		FCI	
ltr	ecr no.	dr	date	linear	0.X ± 0.5	COPY		www.fciconnect.com	
A				linear	0.XX ± 0.25	projection		title	
				angles	0.XXX ± 0.1			5P VERTICAL SOLDER RECEPT	
				dr	0° ± 2°			product family PwrBlade code	
				enr	Warren Du 03/01/10	scale		size	
				chr	Warren Du 03/01/10	1:1		dwg no	
				appd	PM ZHENG 03/01/10	A		51940-339	
					Joseph Hsia 03/01/10			sheet	
sheet index	revision sheet							4 of 4	

cage code 22526