

Type 167/184 Metallized Polyester Radial Lead Capacitors

Radial Box Metallized Polyester Capacitors for Automatic Insertion



The Type 167/184 series radial lead metallized polyester box capacitors are available in bulk (Type 167) or on ammo pack or radial tape and reel (Type 184). These capacitors are constructed in rugged rectangular plastic cases and all come with 7.5 mm (0.3") lead spacing. They are good for general purpose applications such as bypass, decoupling, energy storage/discharge and arc suppression.

Highlights

- Rugged plastic case
- Case and epoxy fill meets UL94V0
- 7.5 mm (0.3") lead spacing
- Bulk, tape and reel or ammo pack
- Non-inductively wound
- Non-polar

Specifications

Capacitance Range	0.001 μ F to 10.5 μ F													
Capacitance Tolerance	\pm 5%, \pm 10%, \pm 20%													
Rated Voltage	63 to 630 Vdc													
Operating Temperature Range	-55 $^{\circ}$ C to +125 $^{\circ}$ C (with 50% Vdc derating >85 $^{\circ}$ C)													
Dielectric Withstand Voltage	1.6 x rated voltage for 2 s @ +25 $^{\circ}$ C \pm 5 $^{\circ}$ C													
Dissipation Factor @ 120 Hz, +25 $^{\circ}$ C	$\text{tg}\delta \times 10^{-4}$ at +25 $^{\circ}$ C \pm 5 $^{\circ}$ C <table border="1" style="margin-left: auto; margin-right: auto;"> <thead> <tr> <th style="text-align: center;">kHz</th> <th style="text-align: center;">$\text{tan}\delta \times 10^{-4}$</th> </tr> </thead> <tbody> <tr> <td style="text-align: center;">1</td> <td style="text-align: center;">\leq100</td> </tr> <tr> <td style="text-align: center;">10</td> <td style="text-align: center;">\leq150</td> </tr> </tbody> </table>		kHz	$\text{tan}\delta \times 10^{-4}$	1	\leq 100	10	\leq 150						
kHz	$\text{tan}\delta \times 10^{-4}$													
1	\leq 100													
10	\leq 150													
Total Self Inductance (L)	Approximately 8 nH													
Maximum Pulse Rise Time (dv/dt)	<table border="1" style="margin-left: auto; margin-right: auto;"> <thead> <tr> <th style="text-align: center;">Vn</th> <th style="text-align: center;">V/μs</th> </tr> </thead> <tbody> <tr> <td style="text-align: center;">63</td> <td style="text-align: center;">12</td> </tr> <tr> <td style="text-align: center;">100</td> <td style="text-align: center;">20</td> </tr> <tr> <td style="text-align: center;">250</td> <td style="text-align: center;">32</td> </tr> <tr> <td style="text-align: center;">400</td> <td style="text-align: center;">41</td> </tr> <tr> <td style="text-align: center;">630</td> <td style="text-align: center;">70</td> </tr> </tbody> </table> <p>If the working voltage (V) is less than the nominal voltage (Vn), the capacitor can work at higher dv/dt. In this case, the maximum value allowed is obtained by multiplying the above value with the ratio Vn/V.</p>		Vn	V/ μ s	63	12	100	20	250	32	400	41	630	70
Vn	V/ μ s													
63	12													
100	20													
250	32													
400	41													
630	70													
Long Term Stability (after two years)	Storage Performance Capacitance Change $\Delta C/C \leq \pm 3\%$	Standard Environmental Conditions												
Regulatory Information														

Type 167/184 Metallized Polyester Radial Lead Capacitors

Capacitor Outline Drawing

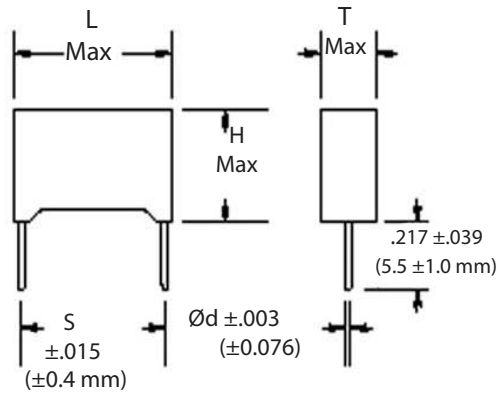

Lead length shown is as supplied on 167 Series

Soldering	
Test Conditions	
Soldering Temperature	260 °C ±5 °C
Soldering Duration	10 sec ±1 sec
Performance	
Capacitance Change $\Delta C/C$	$\leq \pm 2\%$
DF Change $\Delta tg\delta$	$\leq 30 \times 10^{-4}$ at 10 kHz
Insulation Resistance	\geq limit value

Test Method and Performance

Insulation Resistance	
Test Conditions	
Temperature	25 °C ±5 °C
Voltage Charge Time	1 minute
Voltage Charge	50 Vdc for $V_n < 100$ Vdc 100 Vdc for $V_n \geq 100$ Vdc
Performance	
For $V_n > 100$ Vdc	$\geq 30,000$ M Ω (50,000 M Ω typical)
For $V_n \leq 100$ Vdc	$\geq 10,000$ M Ω for $C \leq 0.1 \mu F$ $\geq 1,000$ M $\Omega \times \mu F$ for $> 0.1 \mu F$
Damp Heat Test	
Test Conditions	
Temperature	+40 °C
Relative Humidity	95%
Test Duration	21 days
Performance	
Capacitance Change $\Delta C/C$	$\leq \pm 5\%$
DF Change $\Delta tg\delta$	$\leq 50 \times 10^{-4}$ at 1 kHz
Insulation Resistance	$\geq 50\%$ of limit value
Life Test	
Test Conditions	
Temperature	+85 °C
Test Duration	1000 hrs
Voltage Applied	1.25 x V_n
Performance	
Capacitance Change $\Delta C/C$	$\leq \pm 5\%$
DF Change $\Delta tg\delta$	$\leq 30 \times 10^{-4}$ at 10 kHz
Insulation Resistance	$\geq 50\%$ of limit value

Ratings

Cap (μF)	Catalog Part Number	Tape & Reel Ammo Pack	Inches					Millimeters				
			L	T	H	S	ϕd	L	T	H	S	ϕd
63 Vdc												
.068	167683*63A-F	184683*63#A>-F	0.413	0.157	0.354	0.295	0.024	10.5	4.0	9.0	7.5	0.6
.10	167104*63A-F	184104*63#A>-F	0.413	0.157	0.354	0.295	0.024	10.5	4.0	9.0	7.5	0.6
.15	167154*63A-F	184154*63#A>-F	0.413	0.157	0.354	0.295	0.024	10.5	4.0	9.0	7.5	0.6
.22	167224*63A-F	184224*63#A>-F	0.413	0.157	0.354	0.295	0.024	10.5	4.0	9.0	7.5	0.6
.27	167274*63A-F	184274*63#A>-F	0.413	0.157	0.354	0.295	0.024	10.5	4.0	9.0	7.5	0.6
.33	167334*63A-F	184334*63#A>-F	0.413	0.157	0.354	0.295	0.024	10.5	4.0	9.0	7.5	0.6
.47	167474*63B-F	184474*63#B>-F	0.413	0.197	0.433	0.295	0.024	10.5	5.0	11.0	7.5	0.6
.68	167684*63C-F	184684*63#C>-F	0.413	0.197	0.433	0.295	0.024	10.5	5.0	11.0	7.5	0.6
1.00	167105*63C-F	184105*63#C>-F	0.413	0.236	0.472	0.295	0.024	10.5	6.0	12.0	7.5	0.6
100 Vdc												
.033	167333*100A-F	184333*100#A>-F	0.413	0.157	0.354	0.295	0.024	10.5	4.0	9.0	7.5	0.6
.047	167473*100A-F	184473*100#A>-F	0.413	0.157	0.354	0.295	0.024	10.5	4.0	9.0	7.5	0.6
.068	167683*100A-F	184683*100#A>-F	0.413	0.157	0.354	0.295	0.024	10.5	4.0	9.0	7.5	0.6
.10	167104*100A-F	184104*100#A>-F	0.413	0.157	0.354	0.295	0.024	10.5	4.0	9.0	7.5	0.6
.12	167124*100B-F	184124*100#B>-F	0.413	0.157	0.354	0.295	0.024	10.5	4.0	9.0	7.5	0.6
.15	167154*100B-F	184154*100#B>-F	0.413	0.157	0.354	0.295	0.024	10.5	4.0	9.0	7.5	0.6
.22	167224*100C-F	184224*100#C>-F	0.413	0.197	0.433	0.295	0.024	10.5	5.0	11.0	7.5	0.6
.33	167334*100C-F	184334*100#C>-F	0.413	0.197	0.433	0.295	0.024	10.5	5.0	11.0	7.5	0.6

* Indicates capacitance tolerance: J = $\pm 5\%$, K = $\pm 10\%$, M = $\pm 20\%$

Indicates packaging type: R = Tape and Reel, A = Ammo Pack

> Indicates tooling code: A = 16.5 mm, B = 18.5 mm, C = 16.0 mm (See H dimension in taping specifications)

Type 167/184 Metallized Polyester Radial Lead Capacitors

Cap (μ F)	Catalog Part Number	Tape & Reel Ammo Pack	Inches					Millimeters				
			L	T	H	S	\emptyset d	L	T	H	S	\emptyset d
250 Vdc												
.010	167103*250A-F	184103*250#A>-F	0.413	0.157	0.354	0.295	0.024	10.5	4.0	9.0	7.5	0.6
.015	167153*250A-F	184153*250#A>-F	0.413	0.157	0.354	0.295	0.024	10.5	4.0	9.0	7.5	0.6
.018	167183*250A-F	184183*250#A>-F	0.413	0.157	0.354	0.295	0.024	10.5	4.0	9.0	7.5	0.6
.022	167223*250A-F	184223*250#A>-F	0.413	0.157	0.354	0.295	0.024	10.5	4.0	9.0	7.5	0.6
.027	167273*250B-F	184273*250#B>-F	0.413	0.157	0.354	0.295	0.024	10.5	4.0	9.0	7.5	0.6
.033	167333*250B-F	184333*250#B>-F	0.413	0.157	0.354	0.295	0.024	10.5	4.0	9.0	7.5	0.6
.039	167393*250B-F	184393*250#B>-F	0.413	0.157	0.354	0.295	0.024	10.5	4.0	9.0	7.5	0.6
.047	167473*250B-F	184473*250#B>-F	0.413	0.157	0.354	0.295	0.024	10.5	4.0	9.0	7.5	0.6
.068	167683*250C-F	184683*250#C>-F	0.413	0.197	0.433	0.295	0.024	10.5	5.0	11.0	7.5	0.6
.100	167104*250C-F	184104*250#C>-F	0.413	0.197	0.433	0.295	0.024	10.5	5.0	11.0	7.5	0.6
400 Vdc												
.0047	167472*400A-F	184472*400#A>-F	0.413	0.157	0.354	0.295	0.024	10.5	4.0	9.0	7.5	0.6
.0056	167562*400A-F	184562*400#A>-F	0.413	0.157	0.354	0.295	0.024	10.5	4.0	9.0	7.5	0.6
.0068	167682*400A-F	184682*400#A>-F	0.413	0.157	0.354	0.295	0.024	10.5	4.0	9.0	7.5	0.6
.010	167103*400A-F	184103*400#A>-F	0.413	0.157	0.354	0.295	0.024	10.5	4.0	9.0	7.5	0.6
.015	167153*400B-F	184153*400#B>-F	0.413	0.157	0.354	0.295	0.024	10.5	4.0	9.0	7.5	0.6
.022	167223*400C-F	184223*400#C>-F	0.413	0.197	0.433	0.295	0.024	10.5	5.0	11.0	7.5	0.6
.033	167333*400C-F	184333*400#C>-F	0.413	0.197	0.433	0.295	0.024	10.5	5.0	11.0	7.5	0.6
630 Vdc												
.0010	167102*630A-F	184102*630#A>-F	0.413	0.157	0.354	0.295	0.024	10.5	4.0	9.0	7.5	0.6
.0015	167152*630A-F	184152*630#A>-F	0.413	0.157	0.354	0.295	0.024	10.5	4.0	9.0	7.5	0.6
.0022	167222*630A-F	184222*630#A>-F	0.413	0.157	0.354	0.295	0.024	10.5	4.0	9.0	7.5	0.6
.0033	167332*630A-F	184332*630#A>-F	0.413	0.157	0.354	0.295	0.024	10.5	4.0	9.0	7.5	0.6
.0047	167472*630B-F	184472*630#B>-F	0.413	0.157	0.354	0.295	0.024	10.5	4.0	9.0	7.5	0.6
.0068	167682*630B-F	184682*630#B>-F	0.413	0.157	0.354	0.295	0.024	10.5	4.0	9.0	7.5	0.6
.010	167103*630C-F	184103*630#C>-F	0.413	0.197	0.433	0.295	0.024	10.5	5.0	11.0	7.5	0.6
.015	167153*630D-F	184153*630#D>-F	0.413	0.236	0.472	0.295	0.024	10.5	6.0	12.0	7.5	0.6

* Indicates capacitance tolerance: J = $\pm 5\%$, K = $\pm 10\%$, M = $\pm 20\%$

Indicates packaging type: R = Tape and Reel, A = Ammo Pack

> Indicates tooling code: A = 16.5 mm, B = 18.5 mm, C = 16.0 mm (See H dimension in taping specification)

Part Numbering System for Bulk Items

167	104	K	100	A	-F
Series	Capacitance	Tolerance	Voltage	Case Code	RoHS Compliant Designator
167	392 = .0039 μ F	J = $\pm 5\%$	63 = 63 Vdc	A	
	103 = .01 μ F	K = $\pm 10\%$	100 = 100 Vdc	B	
	104 = .1 μ F	M = $\pm 20\%$	250 = 250 Vdc	C	
	105 = 1.0 μ F		630 = 630 Vdc	D	

Type 167/184 Metallized Polyester Radial Lead Capacitors

Tape Specification - 7.5 mm Lead Spacing

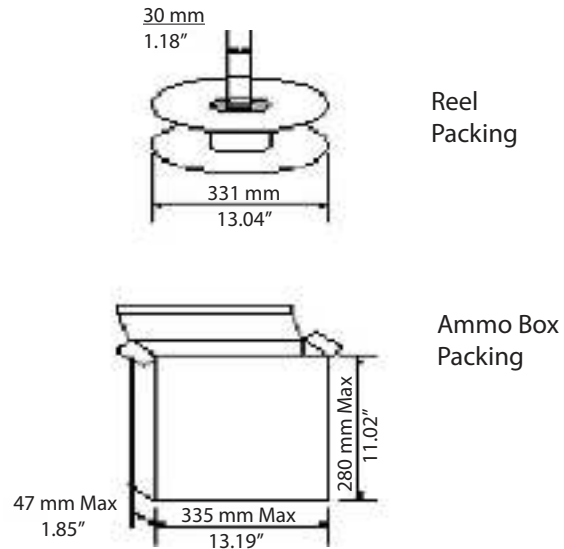
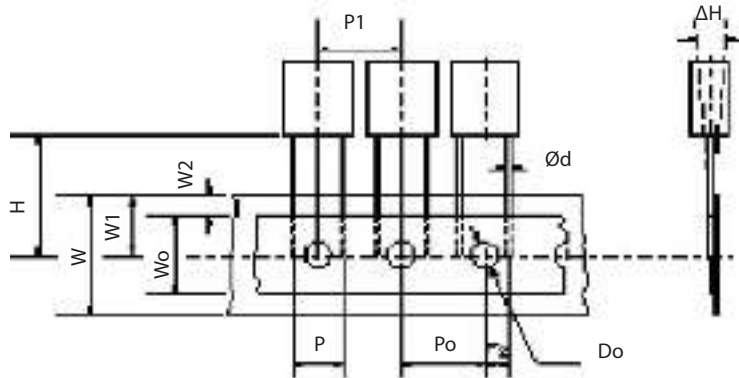

Item	Code	Millimeters	Inches
Lead-Wire Diameter	Ød	0.6 ^{+0.04 -0.01}	.024 ^{±.001}
Lead-to-Lead Distance	P	7.5 ^{+0.6 -0.2}	.295 ^{+0.024 -.040}
Feed Hole Pitch	P ₀	2.7 ^{±0.3}	.5 ^{±.012}
Pitch of Component	P ₁	12.7 ^{±1.0}	.5 ^{±.039}
Hole Center to Lead	P ₂	3.75 ^{±0.7}	.148 ^{±.028}
Component Alignment, F-R	Δh	0 ^{±2.0}	0 ^{±.079}
Tape Width	W	18 ^{+1.0 -0.1}	.709 ^{+0.039 -.004}
Hold-down Tape Width	W ₀	6.0 min	.236 min
Hole Position	W ₁	9.0 ^{+0.75 -0.05}	.355 ^{+0.030 -.001}
Hold-down Tape Position	W ₂	3.0 Max	.118 Max
Height of Component from Tape Center	H	>	>
Feed Hole Diameter	D ₀	4.0 ^{±0.3}	.157 ^{±.012}

Case Code	Quantity Reeled	Quantity Ammo Pack
A	1800	1500
B	1500	1500
C	1200	1000
D	1000	1000

> The H dimension depends on the insertion equipment used. Specify the proper tooling code as indicated below.

Tooling Code	H Dimensions	
	Millimeters	Inches
A	16.5 ^{±0.75}	.679 ^{±0.030}
B	18.5 ^{±0.75}	.728 ^{±0.030}
C	16.0 ^{±0.75}	.630 ^{±0.030}

Part Numbering System for Auto Insertion

184	104	K	100	(#)	A	(>)	-F
Series	Capacitance	Tolerance	Voltage	Packaging Type	Internal Code	*Tooling Code	RoHS Compliant Designator
184	392 = .0039 µF	J = ±5%	63 = 63 Vdc	A = Ammo	A	A	
	103 = .01 µF	K = ±10%	100 = 100 Vdc	R = Tape & Reel	B	B	
	104 = .1 µF	M = ±20%	250 = 250 Vdc	Blank = Bulk	C	C	
	105 = 1.0 µF		630 = 630 Vdc		D	Blank = Bulk	

* Tooling code is at the discretion of the user depending on the insertion equipment being used. See table for specific "H" dimensions

* Tooling code (>) depends on the users insertion equipment requirements. See table for available options.

Type 167/184 Metallized Polyester Radial Lead Capacitors

Notice and Disclaimer: All product drawings, descriptions, specifications, statements, information and data (collectively, the "Information") in this datasheet or other publication are subject to change. The customer is responsible for checking, confirming and verifying the extent to which the Information contained in this datasheet or other publication is applicable to an order at the time the order is placed. All Information given herein is believed to be accurate and reliable, but it is presented without any guarantee, warranty, representation or responsibility of any kind, expressed or implied. Statements of suitability for certain applications are based on the knowledge that the Cornell Dubilier company providing such statements ("Cornell Dubilier") has of operating conditions that such Cornell Dubilier company regards as typical for such applications, but are not intended to constitute any guarantee, warranty or representation regarding any such matter – and Cornell Dubilier specifically and expressly disclaims any guarantee, warranty or representation concerning the suitability for a specific customer application, use, storage, transportation, or operating environment. The Information is intended for use only by customers who have the requisite experience and capability to determine the correct products for their application. Any technical advice inferred from this Information or otherwise provided by Cornell Dubilier with reference to the use of any Cornell Dubilier products is given gratis (unless otherwise specified by Cornell Dubilier), and Cornell Dubilier assumes no obligation or liability for the advice given or results obtained. Although Cornell Dubilier strives to apply the most stringent quality and safety standards regarding the design and manufacturing of its products, in light of the current state of the art, isolated component failures may still occur. Accordingly, customer applications which require a high degree of reliability or safety should employ suitable designs or other safeguards (such as installation of protective circuitry or redundancies or other appropriate protective measures) in order to ensure that the failure of an electrical component does not result in a risk of personal injury or property damage. Although all product-related warnings, cautions and notes must be observed, the customer should not assume that all safety measures are indicated in such warnings, cautions and notes, or that other safety measures may not be required.