

View without cover

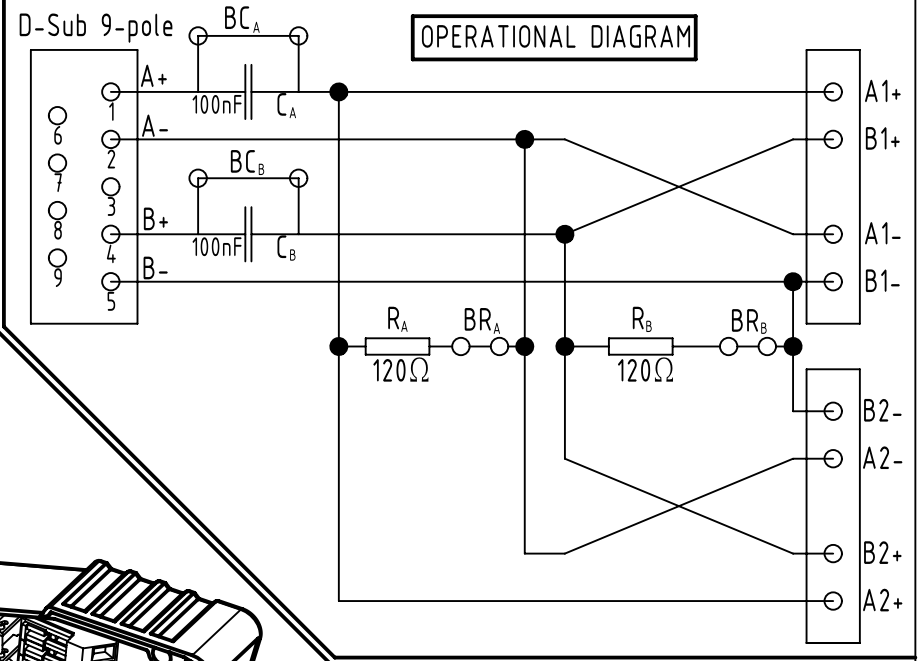
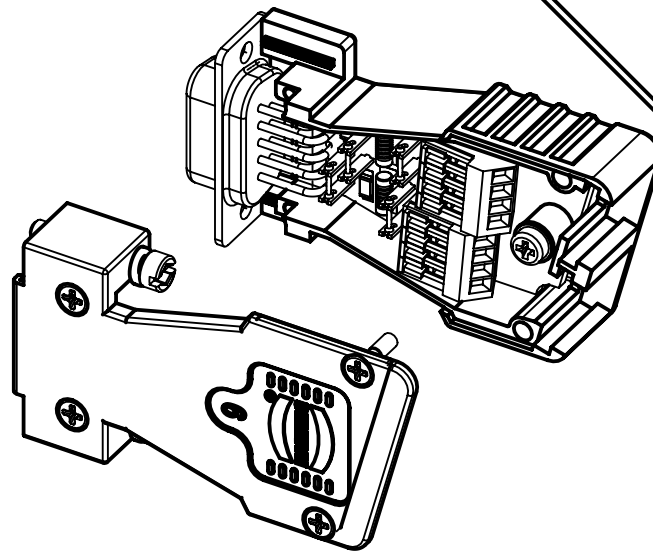
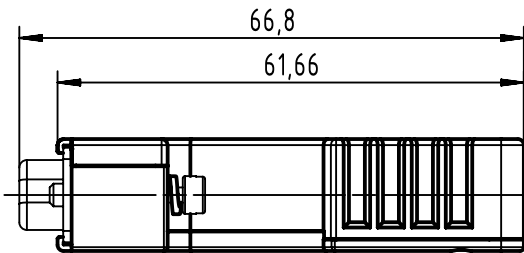
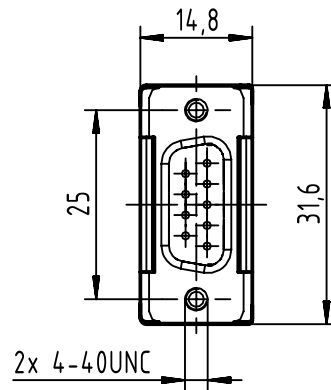
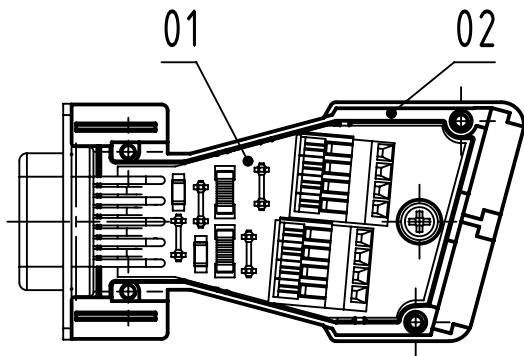

in set inclusive

number	description
2	Crimp flange 6,5-7,5
2	Crimp ferrule 10,0-11,0
1	balcking piece 9-37
1	LABEL line A,B

	All Dimensions in mm Original Size DIN A4		Scale 1:1	Free size tol.		Ref.
	All rights reserved Department EL PD		Created by ZHUANGJ	Inspected by LUOK	Standardisation ROEBEN	Sub.
Date 2021-08-04		State Final Release		Title InduCom 9 male MVB/WTB 4-40UNC		Doc-Key / ECM-Nr. 100073192/UGD/043/B 500000200533
Type TB		Number 66630095014		Rev. B		Page 1/1

6663 009 5014 777	PL1	Small batch
6663 009 5014	PL1	Standard batch
Part number	Performance level	Remark