

High Frequency Ceramic Solutions

Atmel AT86RF215 868/915/928 MHz Impedance Matched Balun + LPF (FCC/ETSI compliant) integrated Passive Component

P/N: 0896BM15E0025

Detail Specification: 4/23/2018

Page 1 of 5

For the 2.4G Balun-filter, go to: www.johansontechnology.com/atmel

General Specifications	
Part Number	0896BM15E0025
Frequency (MHz)	863-928
Unbalanced Impedance	50
Balanced Impedance	Conjugate match to Atmel's AT86RF215, AT86RF215M, AT86RF215IQ chipsets
Power Capacity	1W max. CW
Recommended Storage Conditions for unused T&R product	+5 to +35 °C Humidity 45 - 75%RH 18 months max
Quantity/Reel	4,000 pcs

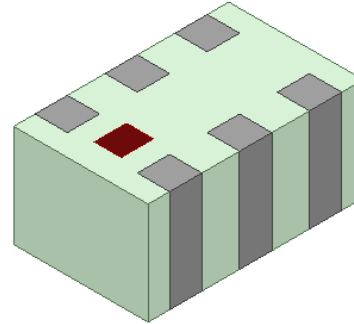

Electrical Specifications		
Operating Temperature	-40°C to +85°C	+85°C to +125°C
Insertion Loss	1.25dB Typ. (1.6dB max.)	1.5dB Typ. (1.8dB max.)
Return Loss	9.5dB min.	9.5dB min.
Phase Balance	180±10	180±10
Amplitude Difference	2.0 max.	2.0 max.
Attenuation	40Typ. 30 min.@ 1726~1856 MHz 45Typ. 34 min.@ 2589~2784 MHz 45Typ. 42 min.@ 3452~3712 MHz 45Typ. 34 min.@ 4315~4640 MHz 54Typ. 31 min.@ 5178~5568 MHz	40Typ. 30 min.@ 1726~1856 MHz 45Typ. 34 min.@ 2589~2784 MHz 45Typ. 42 min.@ 3452~3712 MHz 45Typ. 34 min.@ 4315~4640 MHz 54Typ. 31 min.@ 5178~5568 MHz

Part Number Explanation				
P/N Suffix	Packing Style	Bulk	Suffix = S	eg. 0896BM15E0025S
		T & R	Suffix = E	eg. 0896BM15E0025E
		100% Tin	Suffix = None	eg. 0896BM15E0025(E or S)

Mechanical Dimensions		
	In	mm
L	0.079 ± 0.004	2.00 ± 0.10
W	0.049 ± 0.004	1.25 ± 0.10
T	0.037 ± 0.004	0.95 ± 0.10
a	0.012 ± 0.004	0.30 ± 0.10
b	0.008 ± 0.004	0.20 ± 0.10
c	0.012 +.004/- .008	0.30 +0.1/-0.2
g	0.014 ± 0.004	0.35 ± 0.10
p	0.026 ± 0.002	0.65 ± 0.05

Terminal Configuration			
No.	Function	No.	Function
1	Unbalanced Port	4	Balanced Port
2	GND	5	GND
3	Balanced Port	6	GND

Johanson Technology, Inc. reserves the right to make design changes without notice.
All sales are subject to Johanson Technology, Inc. terms and conditions.



www.johansontechnology.com

4001 Calle Tecate • Camarillo, CA 93012 • TEL 805.389.1166 FAX 805.389.1821

Ver. 2.0

2018 Johanson Technology, Inc. All Rights Reserved

High Frequency Ceramic Solutions

Atmel AT86RF215 868/915/928 MHz Impedance Matched Balun + LPF
(FCC/ETSI compliant) integrated Passive Component

P/N: 0896BM15E0025

Detail Specification: 4/23/2018

Page 2 of 5

Pad-Soldermask Guidelines

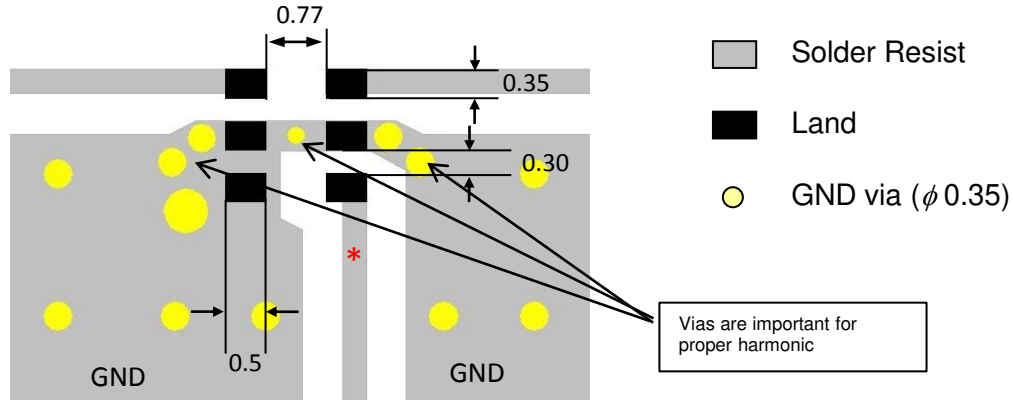

* Line width should be designed to match 50ohm characteristic impedance, depending on PCB material and thickness. Grounded CPWG is recommended.

Schematic and layout file download: www.johansontechnology.com/atmel

Measurement Diagram

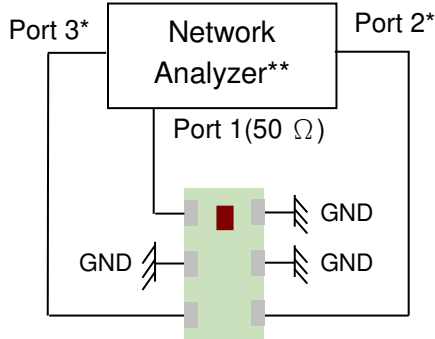

Port 1: Unbalanced Port
Ports 2 and 3: Balanced Port
IL=Sds21
RL=Sss11
Amp_diff = $\text{dB}(S(2,1)/S(3,1))$
Phase_diff = $\text{Phase}(S(2,1)/S(3,1))$

*Impedance for ports 2 and 3 = Balanced Impedance/2
**E5071B from Agilent

Johanson Technology, Inc. reserves the right to make design changes without notice.
All sales are subject to Johanson Technology, Inc. terms and conditions.



www.johansontechnology.com

4001 Calle Tecate • Camarillo, CA 93012 • TEL 805.389.1166 FAX 805.389.1821

Ver. 2.0

2018 Johanson Technology, Inc. All Rights Reserved

High Frequency Ceramic Solutions

Atmel AT86RF215 868/915/928 MHz Impedance Matched Balun + LPF
(FCC/ETSI compliant) integrated Passive Component

P/N: 0896BM15E0025

Detail Specification: 4/23/2018

Page 3 of 5

Schematic

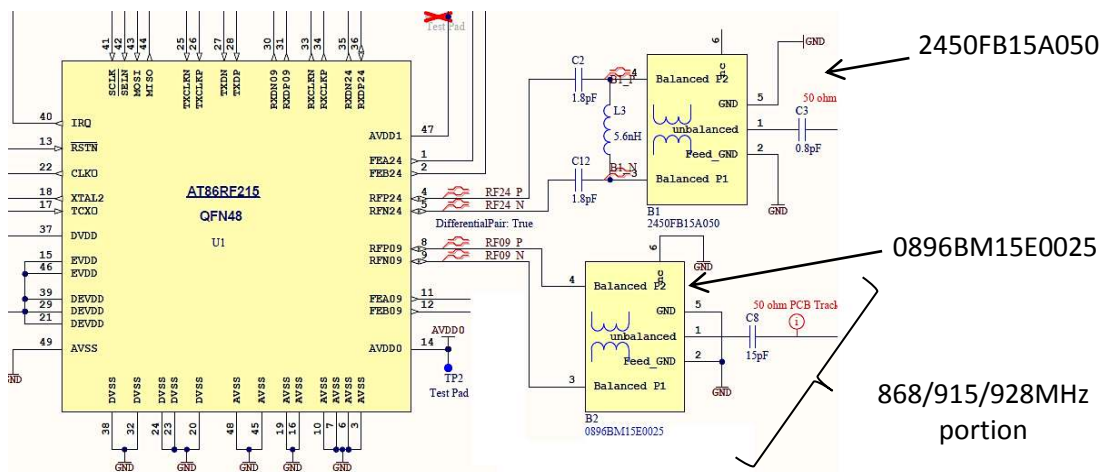

Schematic and layout file download: www.johansontechnology.com/atmel

Layout Mounting Considerations

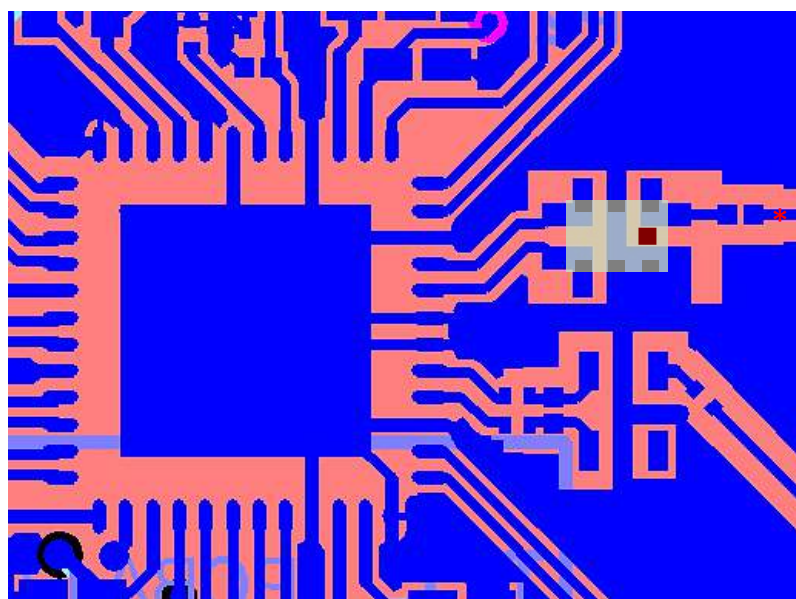

* Line width should be designed to match 50ohm characteristic impedance, depending on PCB material and thickness. Grounded CPW is recommended.

868/915/928MHz portion

2.4GHz portion

Download the complete layout file at at: www.johansontechnology.com/atmel

Johanson Technology, Inc. reserves the right to make design changes without notice.
All sales are subject to Johanson Technology, Inc. terms and conditions.



www.johansontechnology.com

4001 Calle Tecate • Camarillo, CA 93012 • TEL 805.389.1166 FAX 805.389.1821

Ver. 2.0

2018 Johanson Technology, Inc. All Rights Reserved

High Frequency Ceramic Solutions

Atmel AT86RF215 868/915/928 MHz Impedance Matched Balun + LPF
(FCC/ETSI compliant) integrated Passive Component

P/N: 0896BM15E0025

Detail Specification: 4/23/2018

Page 4 of 5

Typical Electrical Characteristics (T=25°C)

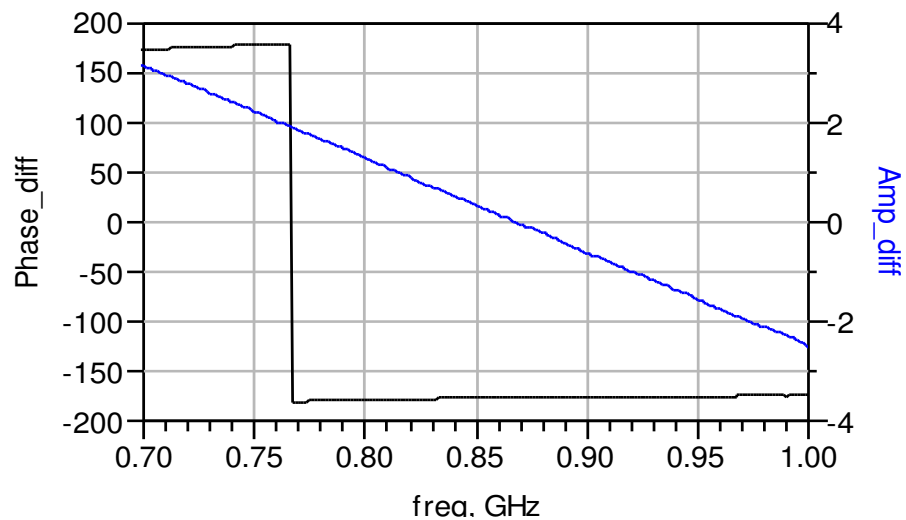
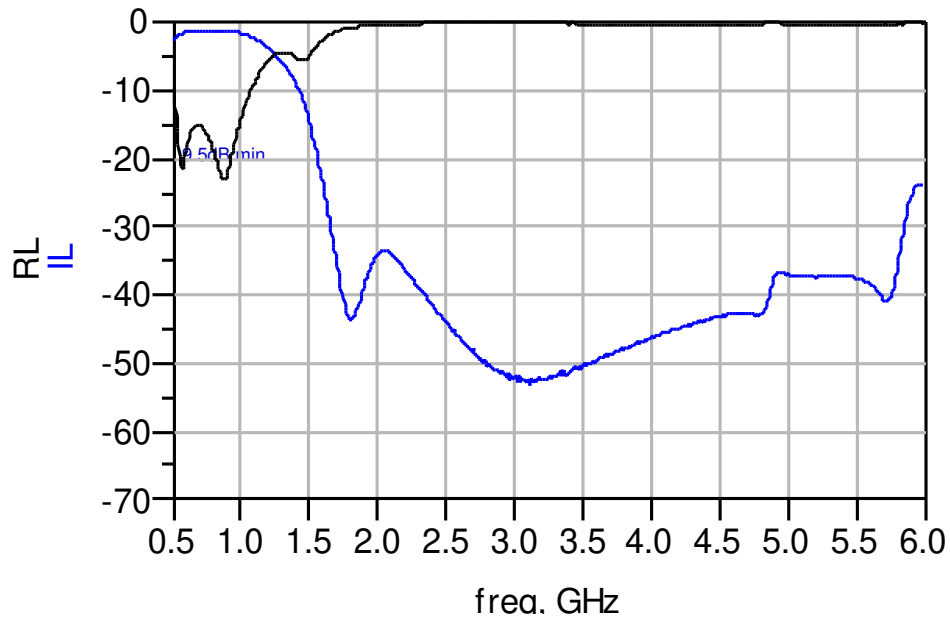

Johanson Technology, Inc. reserves the right to make design changes without notice.
All sales are subject to Johanson Technology, Inc. terms and conditions.



www.johansontechnology.com
4001 Calle Tecate • Camarillo, CA 93012 • TEL 805.389.1166 FAX 805.389.1821
Ver. 2.0

2018 Johanson Technology, Inc. All Rights Reserved

"High Frequency Ceramic Solutions"

Atmel AT86RF215 868/915/928 MHz Impedance Matched Balun + LPF
(FCC/ETSI compliant) integrated Passive Component

P/N: 0896BM15E0025

Detail Specification: 4/23/2018

Page 5 of 5

Application Notes, Layout Files, and more

www.johansontechnology.com/atmel

RoHS Compliance

www.johansontechnology.com/rohs-compliance

Soldering Information

www.johansontechnology.com/ipcsoldering-profile

Antenna layout and tuning techniques

www.johansontechnology.com/tuning

Antenna layout review, tuning, and characterization services

www.johansontechnology.com/ipc-antenna-services

MSL Info

www.johansontechnology.com/msl-rating

Recommended Storage Condition and Max Shelf Life

www.johansontechnology.com/recommended-storage-conditions

Packaging information

www.johansontechnology.com/tape-reel-packaging

Would you like us to review your layout for free and, if needed, recommend you an small antenna solution for your application?

Contact us at:

www.johansontechnology.com/ask-a-question

Johanson Technology, Inc. reserves the right to make design changes without notice.

All sales are subject to Johanson Technology, Inc. terms and conditions.



www.johansontechnology.com
4001 Calle Tecate • Camarillo, CA 93012 • TEL 805.389.1166 FAX 805.389.1821

Ver. 2.0

2018 Johanson Technology, Inc. All Rights Reserved