

CTX50 UN-SEALED RECEPTACLE CRIMP TERMINAL

1.0 SCOPE

This specification details the crimping information and common practices of general crimps for the Molex CTX50 Un-Sealed Receptacle Terminal. Please refer to sales drawing SD-560023-001 for additional part information. The information in this document is for reference and benchmark purposes only. Customers are required to complete their own validation testing if tooling and/or wire is different than what is shown in this specification.

All measurements are in millimeters and Newtons unless specified otherwise.

Terminals shown in this document are generic representations. They are not intended to be an image of any terminal listed in the scope.

2.0 PRODUCT DESCRIPTION

DEFINITION OF TERMS:

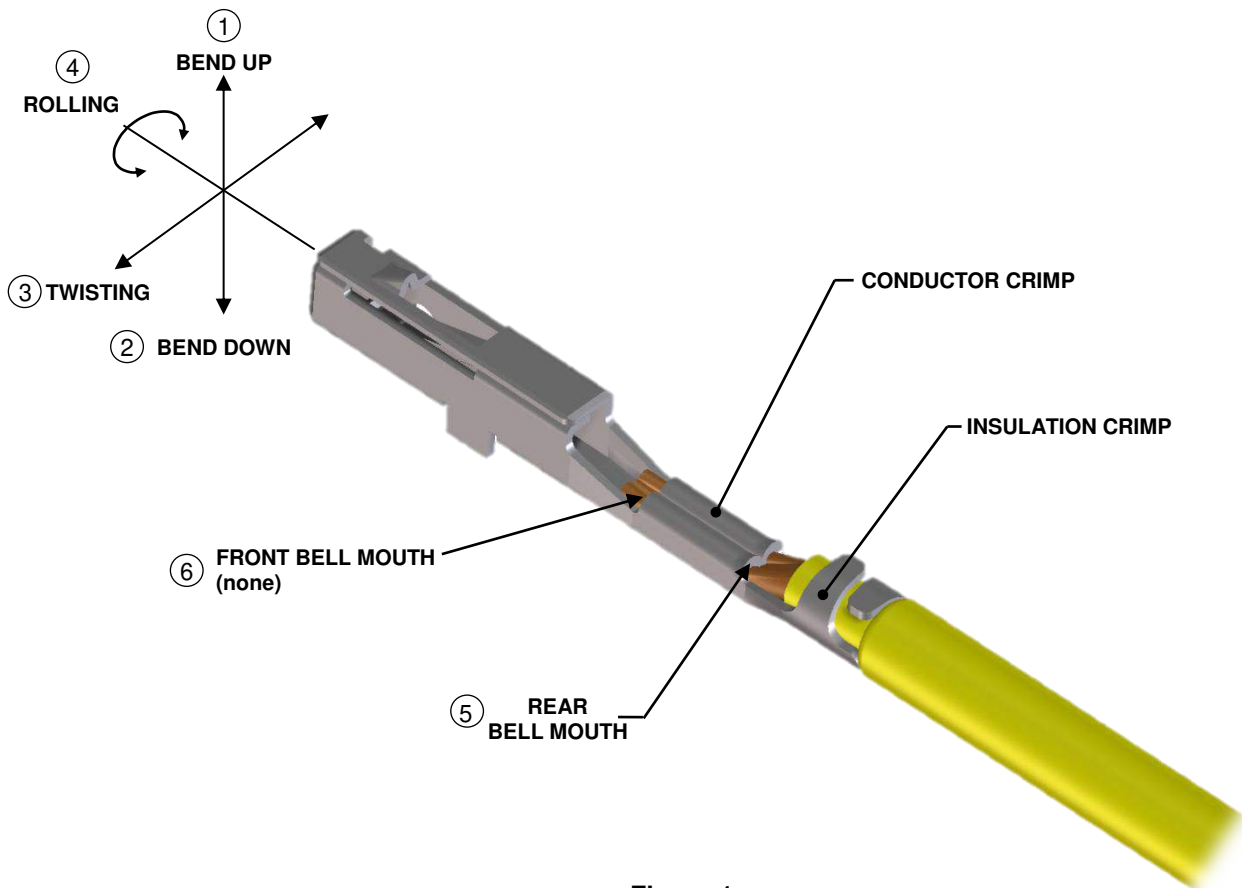

Figure 1

REVISION: C3	ECR/ECN INFORMATION: EC No: 102782 DATE: 02/03/2016	CTX50 UN-SEALED RECEPTACLE APPLICATION SPECIFICATION		SHEET No. 1 of 16
DOCUMENT NUMBER: AS-560023-001		CREATED / REVISED BY: J.Burgio	CHECKED BY: T.Smith	APPROVED BY: B.Moser

DEFINITIONS OF TERMS (CONT.):

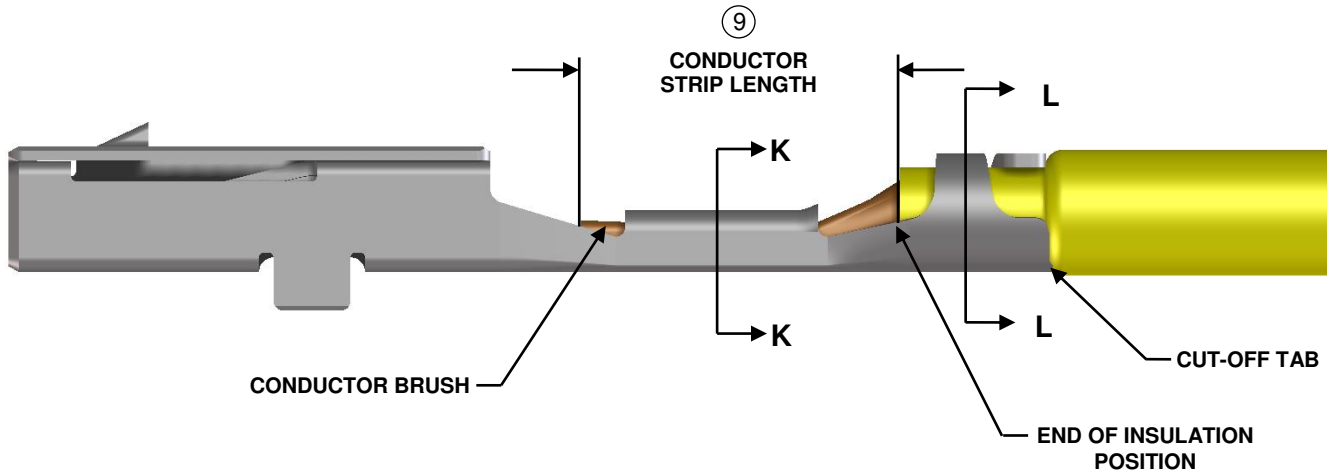

Figure 2

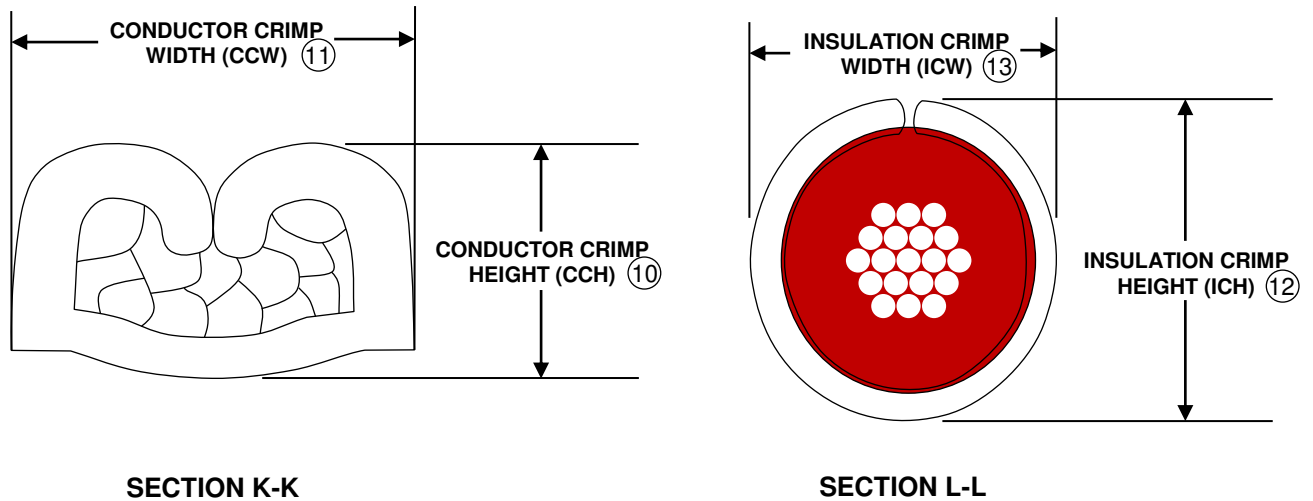

Figure 3

STRAIGHTNESS 1 2 3 4

The crimping process may result in some bending between the conductor crimp and the terminal box. This bending must not exceed the limits shown in Table 4.

REVISION: C3	ECR/ECN INFORMATION: EC No: 102782 DATE: 02/03/2016	CTX50 UN-SEALED RECEPTACLE APPLICATION SPECIFICATION		SHEET No. 2 of 16
DOCUMENT NUMBER: AS-560023-001	CREATED / REVISED BY: J.Burgio	CHECKED BY: T.Smith	APPROVED BY: B.Moser	

BELLMOUTH (FLARE) ⑤ ⑥

The flare that is formed on the edge of the conductor crimp acts as a funnel for the wire strands. This funnel reduces the possibility that a sharp edge on the conductor crimp will cut or nick the wire strands. A rear bellmouth is required on the conductor crimp. CAUTION: Excessively large/small bellmouth may affect mechanical / electrical performance. See Table 3 for bellmouth specifications.

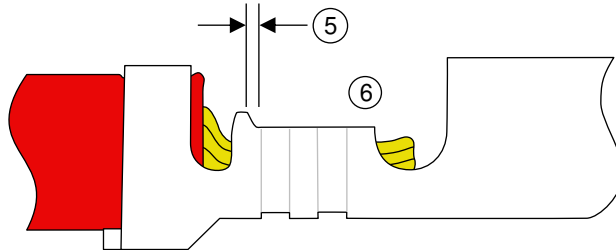

Figure 7

CUT-OFF TAB ⑦

This is the material that protrudes outside the insulation crimp after the terminal is separated from the carrier strip. A cut-off tab that is too long may expose a terminal outside the housing; it may fail electrical spacing requirements. See Table 3 for cut-off tab length specifications.

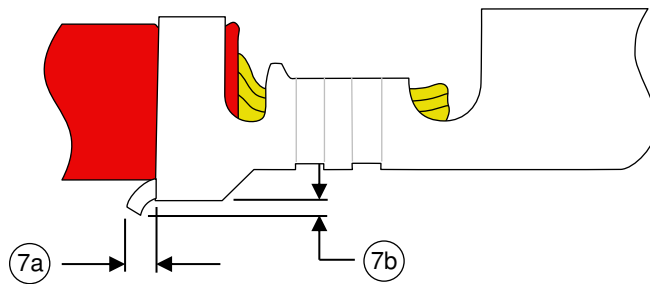

Figure 5

CONDUCTOR BRUSH ⑧

The conductor brush is made up of the wire strands that extend past the conductor crimp into the transition area towards the terminal box. This helps ensure that mechanical compression occurs over the full length of the conductor crimp. The conductor brush should not extend past the transition area into the terminal box or above the conductor crimp/transition wall height (whichever is tallest). CAUTION: Excessive conductor brush extended above the transition/crimp area can cause terminal retention issues inside plastic cavity.

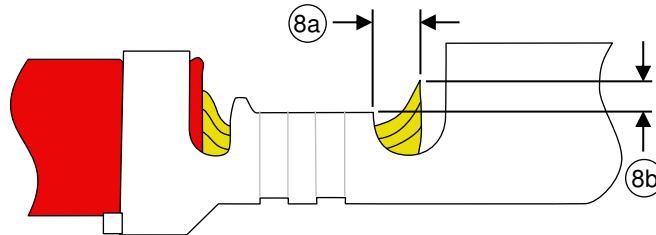

Figure 6

REVISION: C3	ECR/ECN INFORMATION: EC No: 102782 DATE: 02/03/2016	CTX50 UN-SEALED RECEPTACLE APPLICATION SPECIFICATION		SHEET No. 3 of 16
DOCUMENT NUMBER: AS-560023-001		CREATED / REVISED BY: J.Burgio	CHECKED BY: T.Smith	APPROVED BY: B.Moser

CONDUCTOR STRIP LENGTH ⑨

The strip length is determined by measuring the exposed conductor strands after the insulation is removed. The strip length determines the conductor brush length when the end-of-insulation position is centered in the transition area between conductor and insulation crimps. See Table 3 for the length requirement

CAUTION: Care must be taken to ensure that all conductor strands are equal in length (no diagonally cut strands). No scratched or missing strands are permitted. The insulation cut must be uniform (no diagonally cut insulation and no extrusions of insulation).

CONDUCTOR CRIMP

This is the metallurgical compression of a terminal around the wire's conductor. This connection creates a common electrical path with low resistance and high current carrying capabilities.

CONDUCTOR CRIMP HEIGHT/WIDTH ⑩ ⑪

The conductor crimp height is measured from the top surface of the formed crimp to the bottom most radial surface. The conductor crimp width is measured across the widest portion of the crimp. Do not include the extrusion points in these measurements. Measuring crimp height/width is a quick, non-destructive way to help ensure the correct metallurgical compression of a terminal around the wire's conductor and is an excellent attribute for process control. The crimp height/width specification is typically set as a balance between electrical and mechanical performance over the complete range of wire stranding and coatings, and terminal materials and plating. Although it is possible to optimize a crimp height/width to individual wire strands and terminal plating, one crimp height/width specification is normally created. See Table 2 for crimp height/width specifications.

INSULATION CRIMP HEIGHT/WIDTH ⑫ ⑬

Insulation crimp heights/widths are specified in Table 2. CTX50 Un-Sealed Receptacle Terminals are designed to accommodate multiple wire sizes. Although within the terminal range, an insulation grip may not completely surround the wire, an acceptable insulation crimp will still be provided.

The insulation crimp should be visually evaluated to confirm it provides adequate compression on the wire. It should also be evaluated by sectioning through the center of the crimped insulation grip. The grip should compress the insulation but not pierce it or otherwise damage the integrity of the insulation. The grip should not contact the conductors under any circumstance. Mechanically, the insulation grip should withstand repeated flexing of the wire as shown in Figure 7 without pulling out of the grip. The wire is flexed 5 times each in two perpendicular planes in the following sequence: b to a, a to b, b to c, c to b, then repeat (see Figure 7).

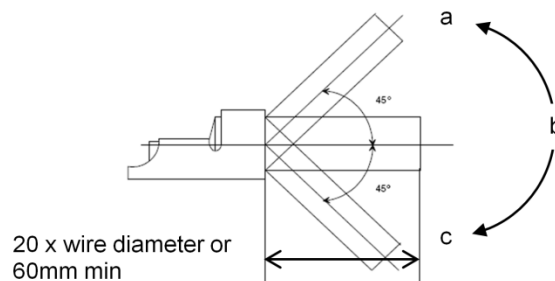

Figure 7

Once the optimum setting for an insulation crimp height is determined, it is important to document it. The operator can then check it as part of the setup procedure.

REVISION: C3	ECR/ECN INFORMATION: EC No: 102782 DATE: 02/03/2016	CTX50 UN-SEALED RECEPTACLE APPLICATION SPECIFICATION		SHEET No. 4 of 16
DOCUMENT NUMBER: AS-560023-001		CREATED / REVISED BY: J.Burgio	CHECKED BY: T.Smith	APPROVED BY: B.Moser

EXTRUSIONS (ANVIL FLASH / BURR) ⑭

These are the small flares that form on the bottom of the conductor crimp resulting from the clearance between the punch and anvil tooling. If the anvil is worn or the terminal is over-crimped, excessive extrusion can result.

An uneven extrusion may also result if the punch and anvil are misaligned, if the feed is misadjusted or if there is insufficient or excessive terminal drag (see Figure 8 and Table 3).

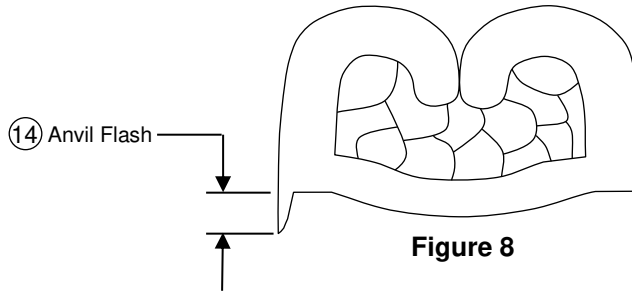

Figure 8

INSULATION GRIP STEP ⑮

The insulation grip step is the designed offset between the conductor grip and the insulation grip which must be met by the crimp process (see Figure 9 and Table 3).

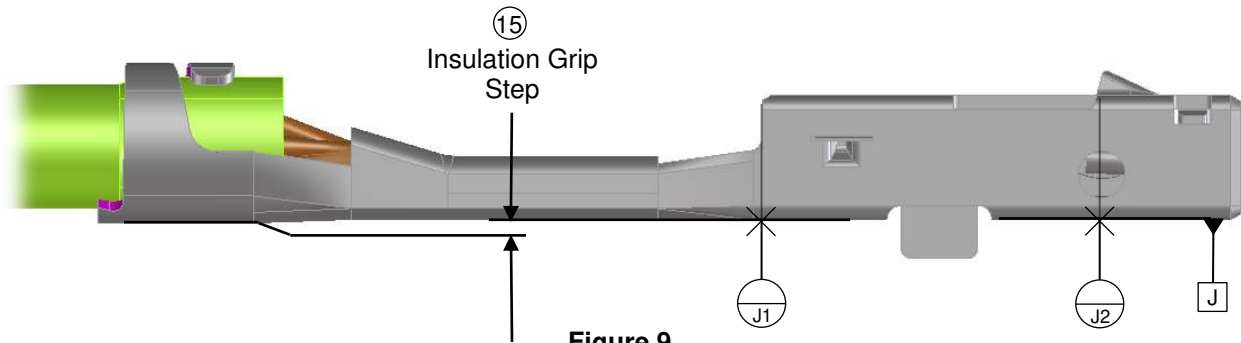

Figure 9

END-OF-INSULATION POSITION

This is the location of the insulation in relation to the transition area between the conductor and insulation crimps. Equal amounts of the conductor strands and insulation needs to be visible in the transition area. The end-of insulation position ensures that the insulation is crimped along the full length of the insulation crimp and that no insulation gets crimped under the conductor crimp. The end-of-insulation position is set by the wire stop and strip length for bench applications. For automatic wire processing applications the end-of-insulation position is set by the in/out press adjustment (see Figure 2).

REVISION: C3	ECR/ECN INFORMATION: EC No: 102782 DATE: 02/03/2016	CTX50 UN-SEALED RECEPTACLE APPLICATION SPECIFICATION		SHEET No. 5 of 16
DOCUMENT NUMBER: AS-560023-001		CREATED / REVISED BY: J.Burgio	CHECKED BY: T.Smith	APPROVED BY: B.Moser

WING DISSYMMETRY (16)

Wing dissymmetry is the crimped offset between the ends of core wings (see Figure 10 and Table 3).

SPACE BETWEEN WING TIPS AND CRIMP BOTTOM (17)

The space between the crimp wing tips and the bottom of the crimp is designed to assure no contact between wing tips and the crimp bottom. Shortest distance is measured. (see Figure 10 and Table 3).

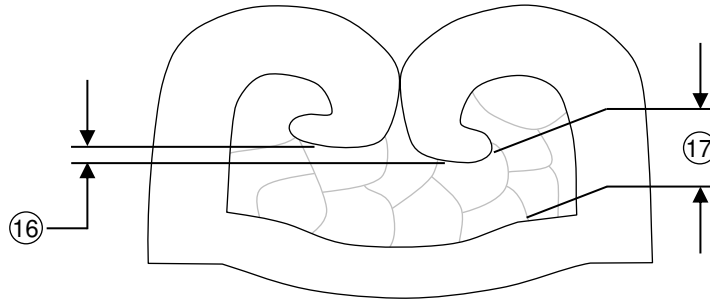

Figure 10

CRIMP BULGE (18)

Caution needs to be taken with the crimp tooling to prevent a bulge in the transition area during crimping. The transition should generally flow smoothly from the conductor crimp to the terminal box. Any bulge must not exceed the width shown in Table 3. See Figure 11 for an example of crimp bulge.

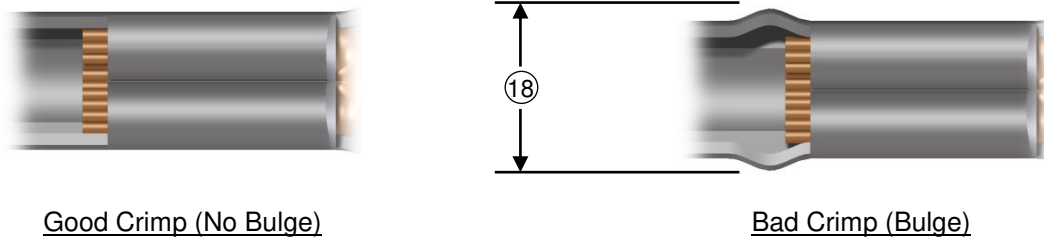

Figure 11

BOX DEFORMATION

Care must be taken to ensure that the terminal box is not deformed during crimping and handling. Any deformation of the terminal box must not exceed the tolerances specified in sales drawing SD-560023-0012.

REVISION: C3	ECR/ECN INFORMATION: EC No: 102782 DATE: 02/03/2016	CTX50 UN-SEALED RECEPTACLE APPLICATION SPECIFICATION		SHEET No. 6 of 16
DOCUMENT NUMBER: AS-560023-001		CREATED / REVISED BY: J.Burgio	CHECKED BY: T.Smith	APPROVED BY: B.Moser

WIRE CONDITION AFTER CRIMP

The wire, after crimping, should not have any scratches, grooves or dents. At a minimum, check the condition of the wire on a sample length of 26mm as shown in Figure 12.

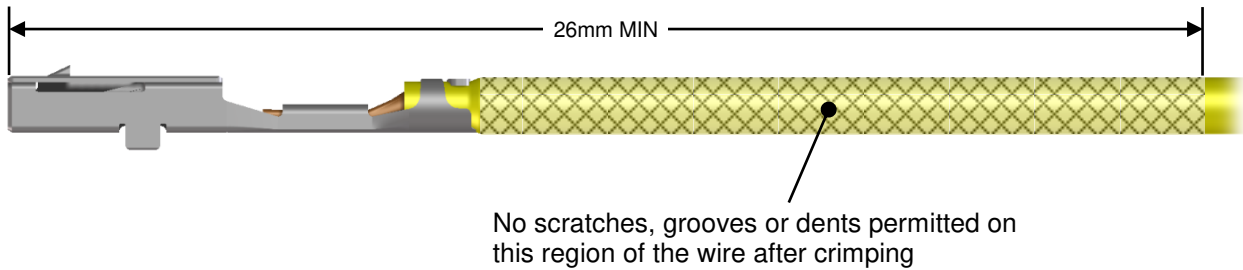

Figure 12

3.0 PRODUCT SPECIFICATIONS

Table 1

Terminal Family	Gender	Sealing	Plating	Special Characteristics	Grip Code	Wire Size	Insulation Diameter Range
CTX50	Receptacle	Un-Sealed	Sn	Standard Performance Tin	S	0.13 mm ²	0.75 – 1.05
			Sn	Standard Performance Tin	M	0.22 mm ²	0.95 – 1.20
			Sn	Standard Performance Tin	L	0.35 mm ²	1.10 – 1.40

REVISION: C3	ECR/ECN INFORMATION: EC No: 102782 DATE: 02/03/2016	CTX50 UN-SEALED RECEPTACLE APPLICATION SPECIFICATION			SHEET No. 7 of 16
DOCUMENT NUMBER: AS-560023-001		CREATED / REVISED BY: J.Burgio	CHECKED BY: T.Smith	APPROVED BY: B.Moser	

Table 2

Molex Product Attribute		Validated Wire			Conductor Barrel		Insulation Barrel		Pull Out Force (N) MIN
Grip Size	Special Characteristics	Conformity Standard	Wire Type	Wire Size	CCH ± 0.03	CCW ± 0.03	ICH ± 0.05	ICW ± 0.05	
S	Standard Performance Tin	GMW15626 Ford ES-BR-1A348-AA ISO 6722 LV112-4	FLCUSN03RY	0.13mm ² ❶	0.53	0.83	1.20	1.10	35
M	Standard Performance Tin	ISO6722 RoHS	CHFUS	0.22mm ² ❷	0.69	1.04	1.25	1.15	40
L	Standard Performance Tin	DIN EN13602 GMW15626 ISO 6722	FLR2X A3ZH	0.35mm ² ❸	0.67±0.02	1.04	1.53	1.35	50

The above specifications are guidelines to an optimum crimp. Crimp heights/widths are applicable for punch/anvil tooling shown in Figures 15 - 19.

Pull force should be measured with no influence from the insulation crimp.

Customers are required to complete their own validation testing if tooling and/or wire is different than what is shown in this specification.

- ❶ Validated to USCAR-21 rev2, Oct 2008; Sections 4.3 & 4.5.2.
- ❷ Validated to PSA STE 96 34115099 Rev. 2007-2008; Sections 5.6.4, 5.6.5.2, 5.6.5.4, 5.6.6.1, 5.6.6.2, 5.6.7.1
- ❸ Validated to USCAR-21 rev2, Oct 2008; Sections 4.3, 4.4 & 4.5.2.

REVISION: C3	ECR/ECN INFORMATION: EC No: 102782 DATE: 02/03/2016	CTX50 UN-SEALED RECEPTACLE APPLICATION SPECIFICATION			SHEET No. 8 of 16
DOCUMENT NUMBER: AS-560023-001		CREATED / REVISED BY: J.Burgio	CHECKED BY: T.Smith	APPROVED BY: B.Moser	



APPLICATION SPECIFICATION

Table 3

Specifications

Balloon #	Feature	Requirement	
1	Bend Up	1° MAX	
2	Bend Down	1° MAX	
3	Twisting	1° MAX	
4	Rolling	1° MAX	
5	Rear Bell Mouth	Grip Code S	0.50 ± 0.10
		Grip Code M	0.50 ± 0.10
		Grip Code L	0.70 ± 0.05
6	Front Bell Mouth	None	
7	Cut-Off Tab	a	0.3 MAX
		b	No Burrs
8	Conductor Brush	a	0.55 MAX
		b	Not to extend above conductor crimp/transition height
9	Conductor Strip Length	0.13mm ² Wire	2.9 for reference
		0.22mm ² Wire	2.9 for reference
		0.35mm ² Wire	3.1 for reference
10	Conductor Crimp Height	See Table 2	
11	Conductor Crimp Width	See Table 2	
12	Insulation Crimp Height	See Table 2	
13	Insulation Crimp Width	See Table 2	
14	Conductor Anvil Flash	0.1 MAX	
15	Insulation Grip Step From J1-J2 (see Figure 9)	Grip Codes S and M	0.00 ± 0.01
		Grip Code L	0.03 ± 0.01
16	Wing Dissymmetry	0.20 MAX	
17	Space Between Wing Tips and Crimp Bottom	Wire ≤ 0.22mm ²	No contact
		Wire ≥ 0.35mm ²	0.10 MIN
18	Crimp Bulge	1.05 MAX	

REVISION: C3	ECR/ECN INFORMATION: EC No: 102782 DATE: 02/03/2016	CTX50 UN-SEALED RECEPTACLE APPLICATION SPECIFICATION		SHEET No. 9 of 16
DOCUMENT NUMBER: AS-560023-001	CREATED / REVISED BY: J.Burgio	CHECKED BY: T.Smith	APPROVED BY: B.Moser	

4.0 REFERENCE DOCUMENTS

Reference documentation for general practices is located on the website per the below links:

1. Molex Quality Crimping Handbook http://www.molex.com/images/products/apptool/qual_crimp.pdf
2. Molex-Recognizing Good Crimps <http://www.molex.com>, search for Application Tooling

5.0 PROCEDURE

5.1 GENERAL MEASUREMENT AND EVALUATION REQUIREMENTS

Crimp Height Measurement (Anvil Flash Evaluation)

1. Complete tool set-up procedure.
2. Crimp a minimum of 5 samples.
3. Place the flat blade of the crimp micrometer across the center of the dual radii of the conductor crimp. Do not take the measurement near the conductor bell mouth (see Figure 13).
4. Rotate the micrometer dial until the point contacts the bottom most radial surface. If using a caliper, be certain not to measure the conductor anvil flash (extrusions) of the crimp (see Figure 14).

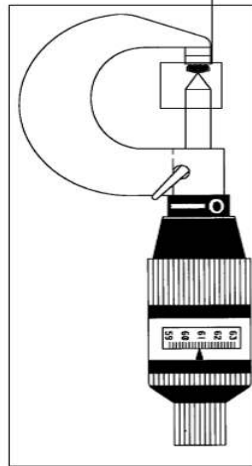
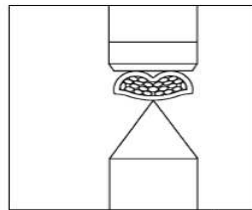

Figure 13

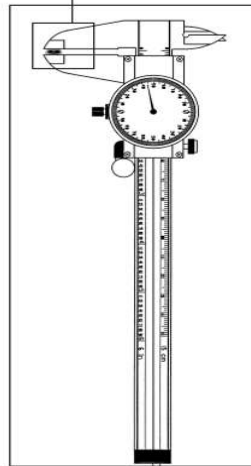
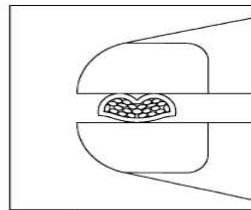
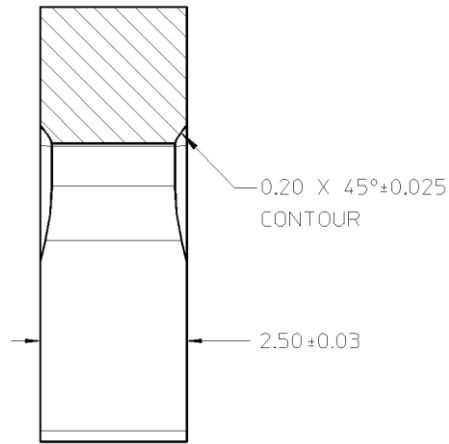

Figure 14

6.0 CRIMP TOOLING GEOMETRY

The crimp tooling information shown below defines the tooling used by Molex to perform validation testing to establish recommended crimp height and widths. The user is responsible for validating crimp performance based on tooling, equipment and wire that is being used.

REVISION: C3	ECR/ECN INFORMATION: EC No: 102782 DATE: 02/03/2016	CTX50 UN-SEALED RECEPTACLE APPLICATION SPECIFICATION		SHEET No. 10 of 16
DOCUMENT NUMBER: AS-560023-001	CREATED / REVISED BY: J.Burgio	CHECKED BY: T.Smith	APPROVED BY: B.Moser	



SECTION Z-Z

NOTE:

CONTOUR GROUND, POLISHED, AND BUFFED TO A 0.5-2.0 MICRO/IN. FINISH
 WHEN POLISHING, CARE MUST BE TAKEN TO ENSURE THAT THE TIP CREATED BY THE TWO RADII MAINTAINS DEFINITION, SYMMETRY, AND SHARPNESS

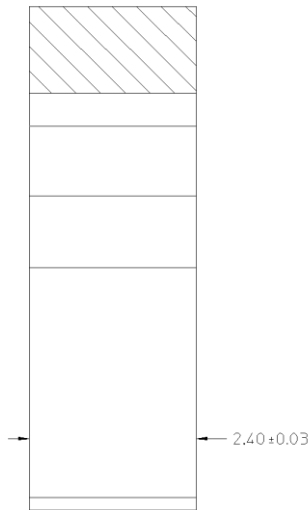
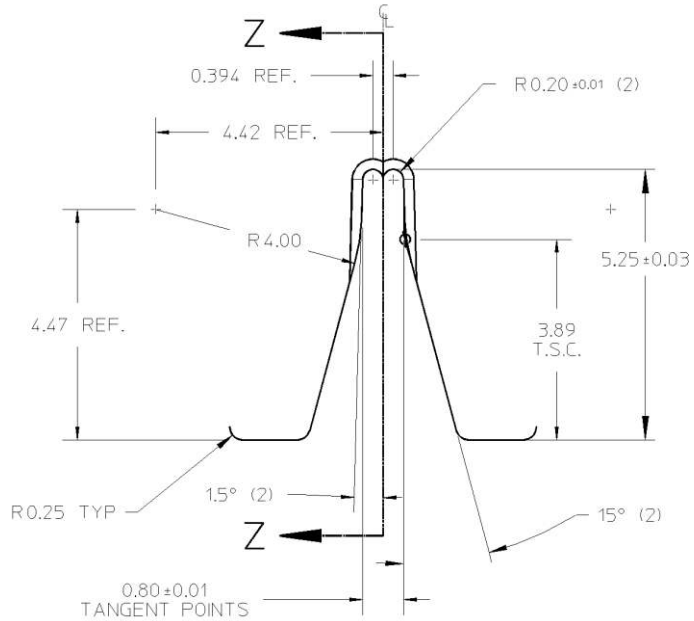

SECTION Z-Z

NOTE:

CONTOUR GROUND, POLISHED, AND BUFFED TO A 0.5-2.0 MICRO/IN. FINISH

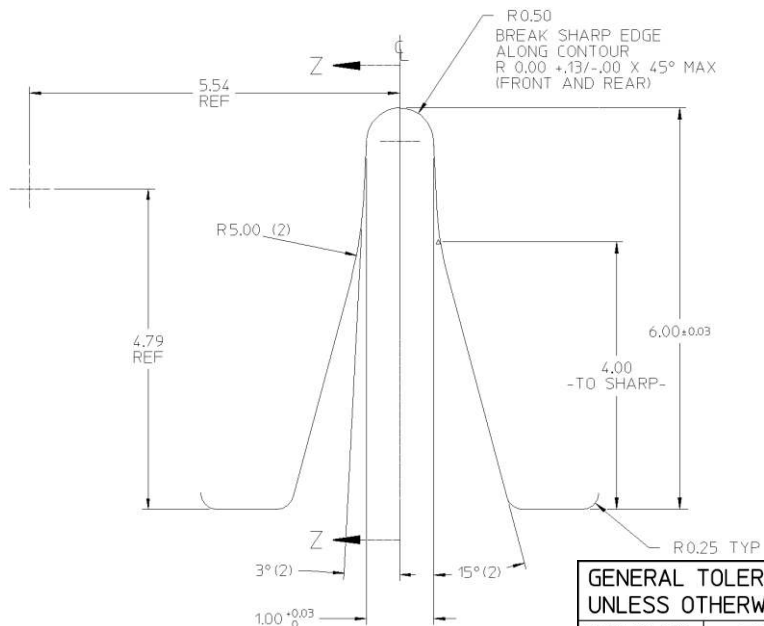

Figure 15
Grip Size S ONLY

GENERAL TOLERANCE UNLESS OTHERWISE SPECIFIED		
DEC. PLCS.	MM	INCH
4 PLACES	± ---	± ---
3 PLACES	± ---	± ---
2 PLACES	± 0.13	± ---
1 PLACE	± 0.25	± ---
ANGULAR	± 0.5°	

REVISION:	ECR/ECN INFORMATION:
C3	EC No: 102782
	DATE: 02/03/2016

CTX50 UN-SEALED RECEPTACLE APPLICATION SPECIFICATION

SHEET No.
11 of 16

DOCUMENT NUMBER:
AS-560023-001

CREATED / REVISED BY:
J.Burgio

CHECKED BY:
T.Smith

APPROVED BY:
B.Moser

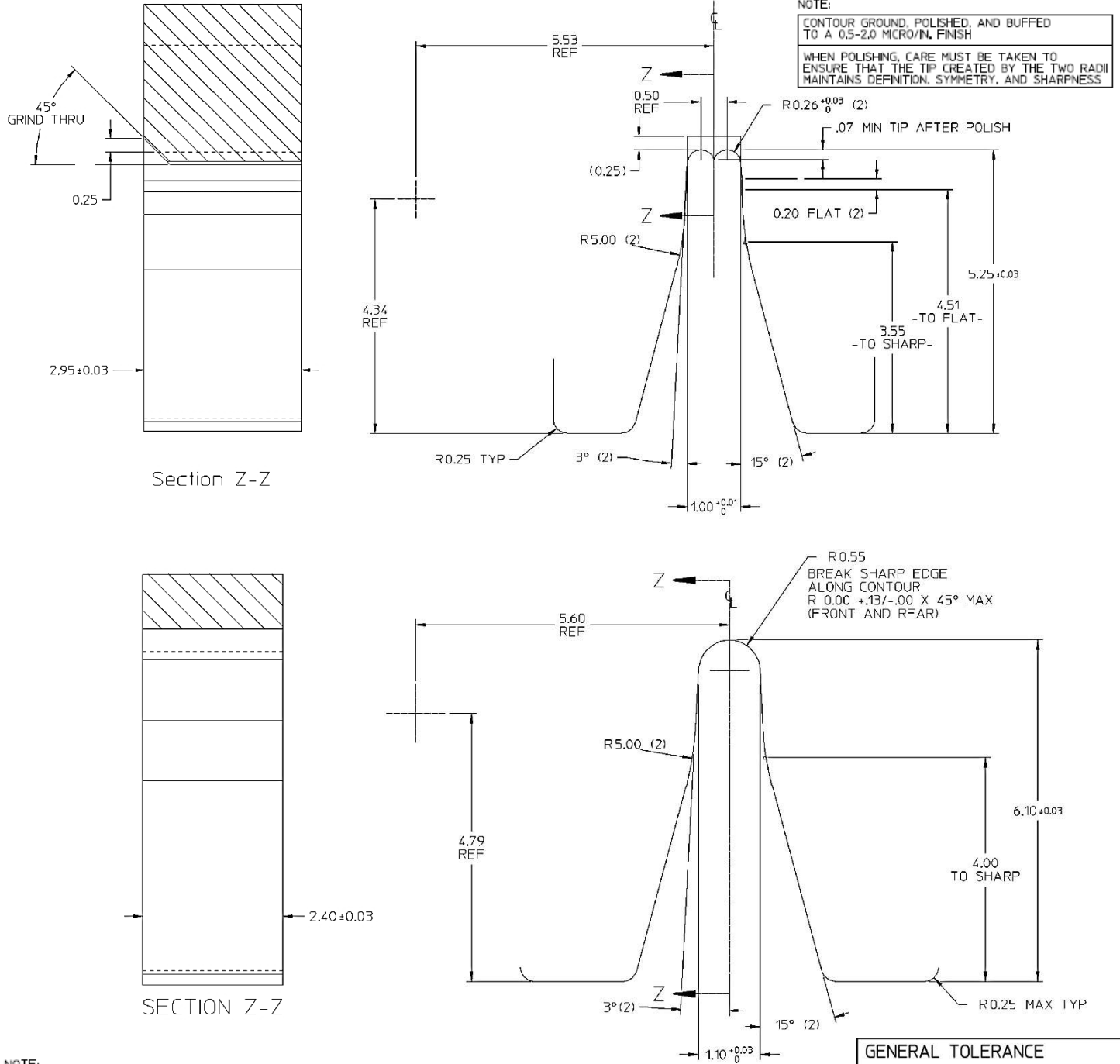

NOTE:
 CONTOUR GROUND, POLISHED, AND BUFFED TO A 0.5-2.0 MICRO/IN. FINISH
 WHEN POLISHING, CARE MUST BE TAKEN TO ENSURE THAT THE TIP CREATED BY THE TWO RADII MAINTAINS DEFINITION, SYMMETRY, AND SHARPNESS

NOTE:
 CONTOUR GROUND, POLISHED, AND BUFFED TO A 0.5-2.0 MICRO/IN. FINISH

GENERAL TOLERANCE UNLESS OTHERWISE SPECIFIED		
DEC. PLCS.	MM	INCH
4 PLACES	± ---	± ---
3 PLACES	± ---	± ---
2 PLACES	± 0.13	± ---
1 PLACE	± 0.25	± ---
ANGULAR	± 0.5°	

Figure 16
 Grip Size M ONLY

REVISION:	ECR/ECN INFORMATION:	CTX50 UN-SEALED RECEPTACLE APPLICATION SPECIFICATION		SHEET No.
C3	EC No: 102782 DATE: 02/03/2016			12 of 16
DOCUMENT NUMBER:	CREATED / REVISED BY:	CHECKED BY:	APPROVED BY:	
AS-560023-001	J.Burgio	T.Smith	B.Moser	

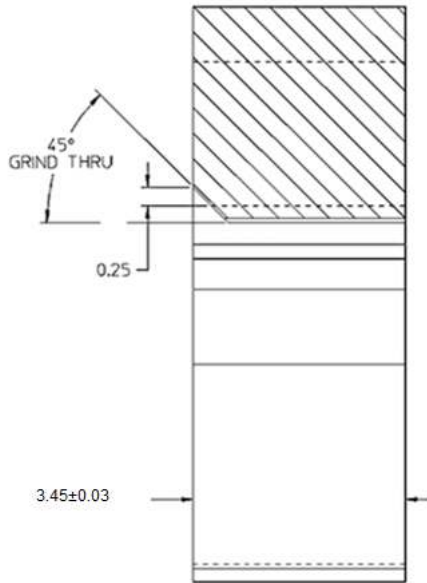

Section Z-Z

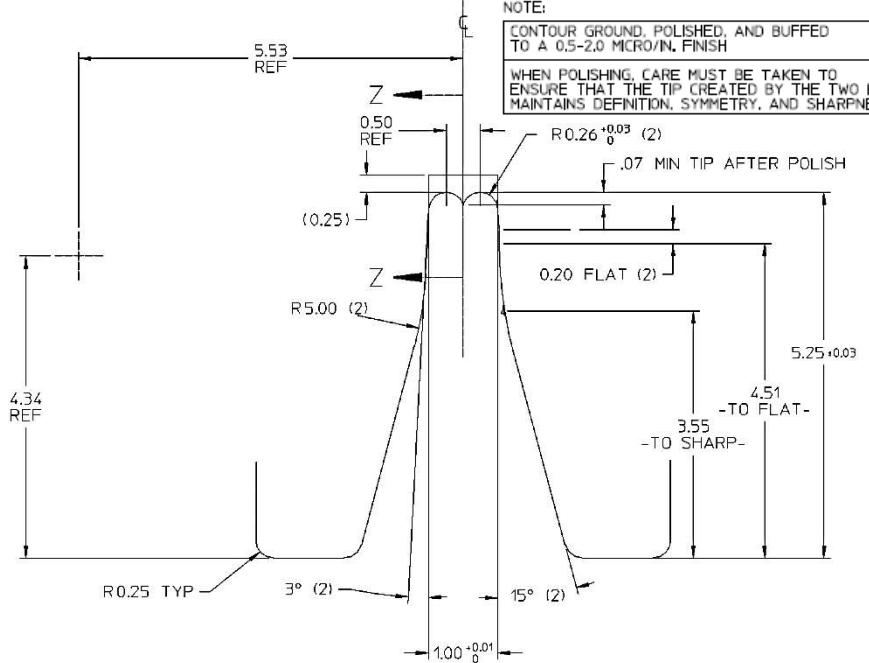

SECTION Z-Z

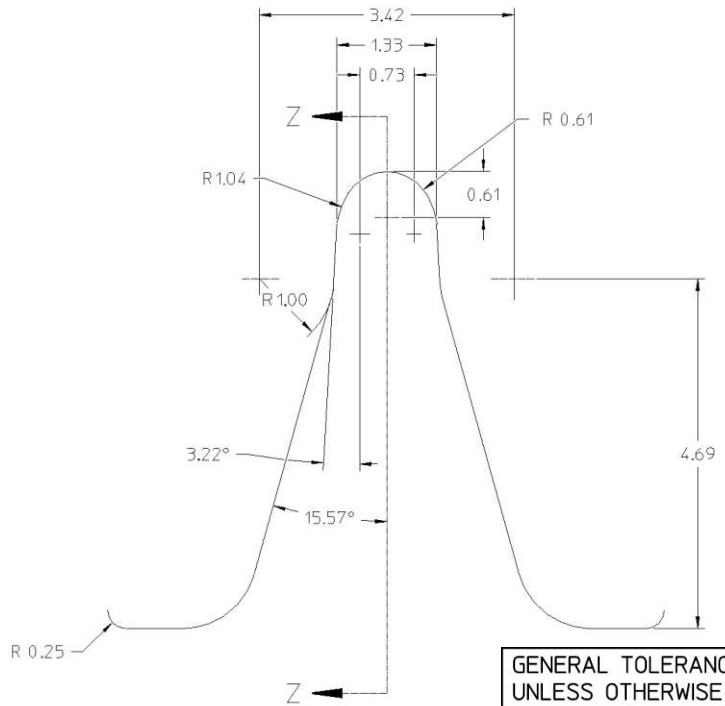

GENERAL TOLERANCE UNLESS OTHERWISE SPECIFIED		
DEC. PLCS.	mm	INCH
4 PLACES	± ---	± ---
3 PLACES	± ---	± ---
2 PLACES	± 0.13	± ---
1 PLACE	± 0.25	± ---
ANGULAR	± 0.5°	

NOTE:
CONTOUR GROUND, POLISHED, AND BUFFED TO A 0.5-2.0 MICRO/IN. FINISH

Figure 17
Grip Size L ONLY

REVISION: C3	ECR/ECN INFORMATION: EC No: 102782 DATE: 02/03/2016	CTX50 UN-SEALED RECEPTACLE APPLICATION SPECIFICATION		SHEET No. 13 of 16
DOCUMENT NUMBER: AS-560023-001	CREATED / REVISED BY: J.Burgio	CHECKED BY: T.Smith	APPROVED BY: B.Moser	

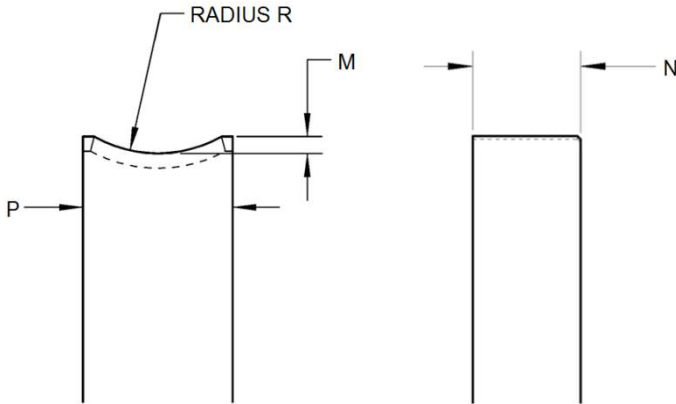

Figure 18

Conductor Anvil Geometry – All Grip Sizes

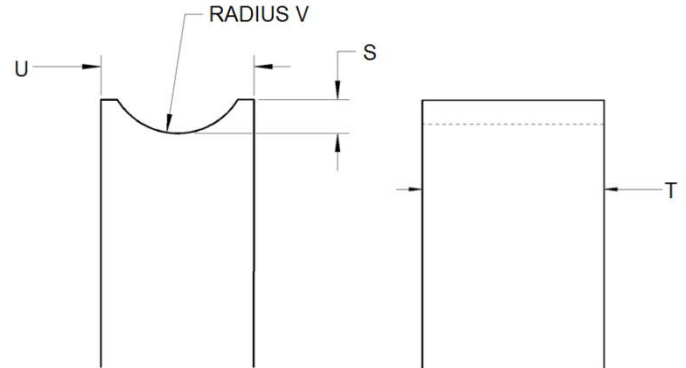

Figure 19

Insulator Anvil Geometry – All Grip Sizes

Table 4
(see Figures 18 and 19 for geometry)

Grip Size	M ±0.01	N ±0.01	P ±0.01	R ±0.03	S ±0.03	T ±0.03	U +0 -0.03	V ±0.05
S	0.10	3.45	0.80	0.65	0.10	2.20	0.96	0.62
M	0.12	3.45	1.02	0.87	0.11	2.20	1.06	0.69
L	0.12	3.95	1.02	0.87	0.29 ±0.025	2.00 ±0.025	1.32 ±0.013	0.61 ±0.025

GENERAL TOLERANCE UNLESS OTHERWISE SPECIFIED		
DEC. PLCS.	mm	INCH
4 PLACES	± ---	± ---
3 PLACES	± ---	± ---
2 PLACES	± 0.13	± ---
1 PLACE	± 0.25	± ---
ANGULAR	± 0.5°	

REVISION: C3	ECR/ECN INFORMATION: EC No: 102782 DATE: 02/03/2016	CTX50 UN-SEALED RECEPTACLE APPLICATION SPECIFICATION		SHEET No. 14 of 16
DOCUMENT NUMBER: AS-560023-001	CREATED / REVISED BY: J.Burgio	CHECKED BY: T.Smith	APPROVED BY: B.Moser	

7.0 CRIMP STRAIGHTNESS

A sample method for maintaining crimp straightness is shown in Figure 20 below.

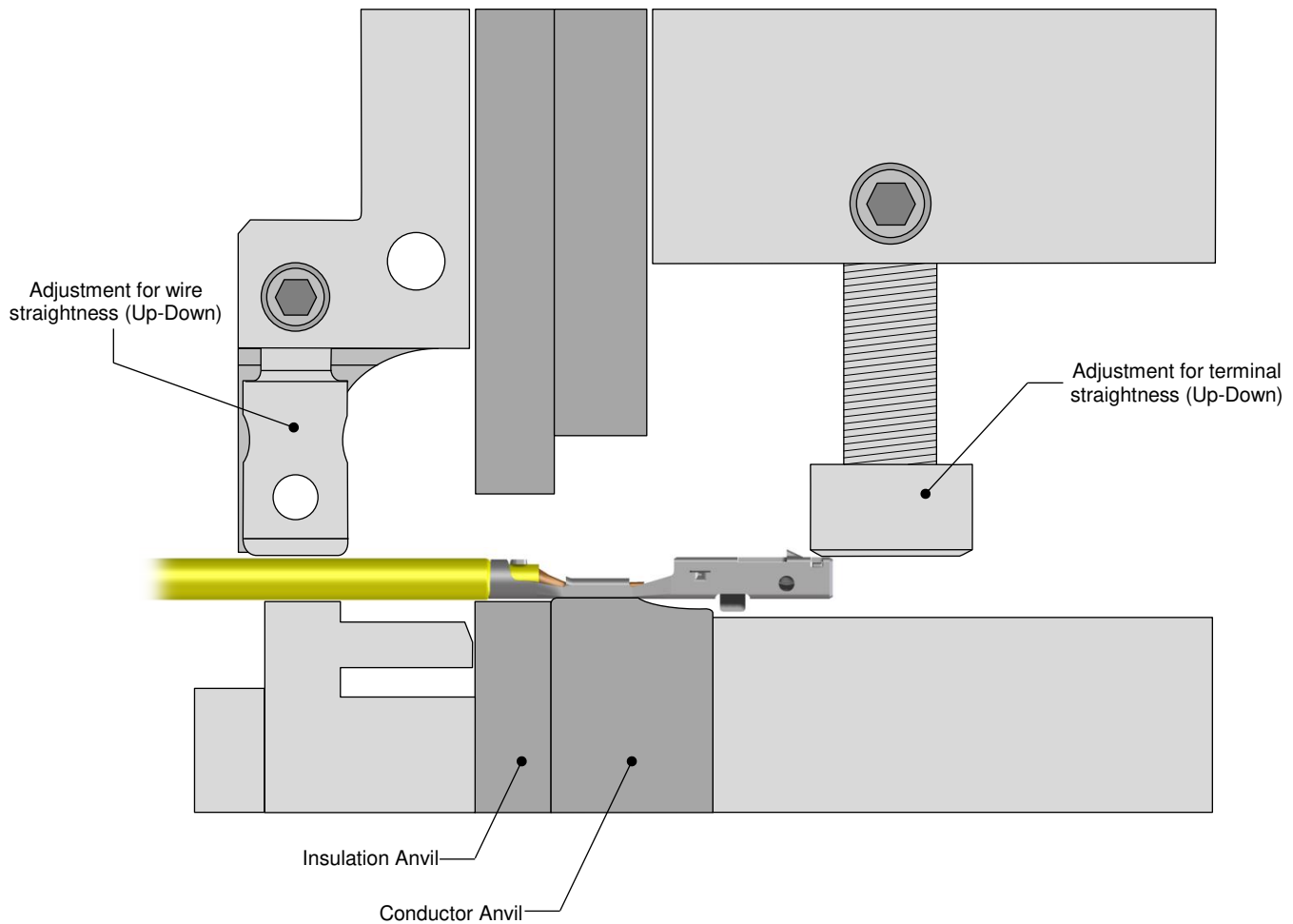

Figure 20

REVISION: C3	ECR/ECN INFORMATION: EC No: 102782 DATE: 02/03/2016	CTX50 UN-SEALED RECEPTACLE APPLICATION SPECIFICATION		SHEET No. 15 of 16
DOCUMENT NUMBER: AS-560023-001		CREATED / REVISED BY: J.Burgio	CHECKED BY: T.Smith	APPROVED BY: B.Moser

8.0 APPLICATION TOOLING

Application Tooling for the CTX50 Receptacle Terminal can be obtained directly from Molex.

To find the proper and latest Molex Application Tooling

1. Go to <http://www.molex.com>
2. Enter the terminal / connector part number into the search box and select the "Go" button.
 - a. Molex part numbers can also be found by searching on the product description.
3. Review the Application Tooling available on the right side of the product window.
 - a. It may be necessary to scroll down on the right side of the terminal / connector product page to view all the tooling options.
 - b. Hand tools and manual type tools require the loose terminal / connector part number to be used in the search.
 - c. Applicator or semi-automatic type tools require the reeled terminal / connector part number to be used in the search.
4. Select the tool part number link
5. Review the tooling page for general tool information
6. Open the link for the Application Tooling Specification (ATS) (located on the left under *Specifications & Other Documents*) for additional details such as:
 - a. Termination specifications: crimp height, pull force, wire strip length, insulation diameter, etc.
 - b. Tool information: tool diagram, tool parts list, repair parts, perishable parts list.
7. Order Molex Application Tooling through your preferred distributor

Notes:

1. Hand crimp tooling can only be used with certain wires and terminal part numbers. Check the Application Tooling Specification Sheet on the Molex website for details.
2. Application Tooling product numbers are subject to change without prior notice. Customers are advised to check the Molex website for the most up-to-date information.
3. Molex FineAdjust™ and MiniMac™ Application Tooling requires the use of left payoff ("D" Wind) parts.

REVISION: C3	ECR/ECN INFORMATION: EC No: 102782 DATE: 02/03/2016	CTX50 UN-SEALED RECEPTACLE APPLICATION SPECIFICATION		SHEET No. 16 of 16
DOCUMENT NUMBER: AS-560023-001		CREATED / REVISED BY: J.Burgio	CHECKED BY: T.Smith	APPROVED BY: B.Moser