

TCM1030, TCM1050 DUAL TRANSIENT-VOLTAGE SUPPRESSORS

SCTS040B – JUNE 1989 – REVISED JUNE 1997

- Meet or Exceed Bell Standard LSSGR Requirements
- Externally-Controlled Negative Firing Voltage . . . –90 V Max
- Accurately Controlled, Wide Negative Firing Voltage Range . . . –5 V to –85 V
- Positive Surge Current (see Note 1):

	TCM1030	TCM1050
10/1000	16 A	30 A
10/160	25 A	45 A
2/10	35 A	50 A
- Negative Surge Current (see Note 1):

	TCM1030	TCM1050
10/1000	–16 A	–25 A
10/160	–25 A	–29 A
2/10	–35 A	–36 A
- High Holding Current
 - TCM1030 . . . 100 mA Min
 - TCM1050 . . . 150 mA Min

D OR P PACKAGE
(TOP VIEW)

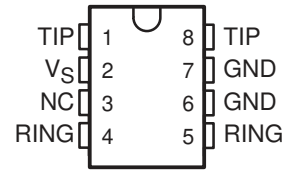

NC – No internal connection
The D package is available taped and reeled. Add R suffix (i.e., TCM1030DR).

description

The TCM1030 and TCM1050 dual transient-voltage suppressors are designed specifically for telephone line card protection against lightning and transients (voltage transients) induced by ac lines. One of the TIP terminals (pin 1 or 8) and one of the RING terminals (pin 4 or 5) are connected to the tip and ring circuits of a SLIC (subscriber-line interface circuit). The battery feed connections between the SLIC and the subscriber line are from the remaining TIP (pin 1 or 8) and RING (pin 4 or 5) through the TCM1030 or the TCM1050 to the tip and ring lines. Transients are suppressed between tip and ground, and ring and ground.

Positive transients are clamped by diodes D1 and D2. Negative transients that are more negative than V_S cause the SCRs, Q1 and Q2, to crowbar. The high holding current of the SCRs prevent dc latchup as the transient subsides.

The TCM1030 and TCM1050 are characterized for operation from -40°C to 85°C .

NOTE 1: The notation 10/1000 refers to a waveshape having $t_r = 10 \mu\text{s}$ and $t_w = 1000 \mu\text{s}$ ending at 50% of the peak value. The notation 10/160 is $t_r = 10 \mu\text{s}$ and $t_w = 160 \mu\text{s}$. The notation 2/10 is $t_r = 2 \mu\text{s}$ and $t_w = 10 \mu\text{s}$.



Please be aware that an important notice concerning availability, standard warranty, and use in critical applications of Texas Instruments semiconductor products and disclaimers thereto appears at the end of this data sheet.

PRODUCTION DATA information is current as of publication date. Products conform to specifications per the terms of Texas Instruments standard warranty. Production processing does not necessarily include testing of all parameters.

 **TEXAS
INSTRUMENTS**

POST OFFICE BOX 655303 • DALLAS, TEXAS 75265

Copyright © 1997, Texas Instruments Incorporated

TCM1030, TCM1050 DUAL TRANSIENT-VOLTAGE SUPPRESSORS

SCTS040B – JUNE 1989 – REVISED JUNE 1997

functional block diagram

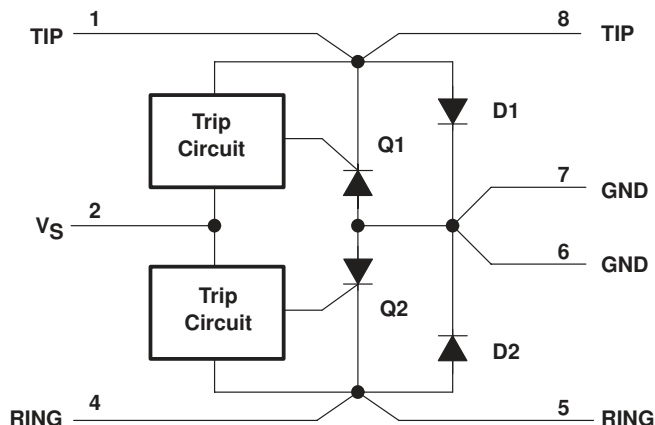

absolute maximum ratings over operating free-air temperature range (unless otherwise noted)†

TCM1030 nonrepetitive peak surge current (see Note 1):	10/1000	±16 A
	10/160	±25 A
	2/10	±35 A
TCM1050 nonrepetitive peak positive surge current: (see Note 1)	10/1000	30 A
	10/160	45 A
	2/10	50 A
TCM1050 nonrepetitive peak negative surge current: (see Note 1)	10/1000	-25 A
	10/160	-29 A
	2/10	-36 A
Nonrepetitive peak surge current, $t_w = 10$ ms, half sinewave (see Note 2)		5 A
Continuous 60-Hz sinewave at 1 A		2 s
Continuous total power dissipation		See Dissipation Rating Table
Operating free-air temperature range, T_A		-40°C to 85°C
Storage temperature range, T_{stg}		-40°C to 150°C
Lead temperature 1,6 mm (1/16 inch) from case for 10 seconds: D or P package		260°C

† Stresses beyond those listed under “absolute maximum ratings” may cause permanent damage to the device. These are stress ratings only, and functional operation of the device at these or any other conditions beyond those indicated under “recommended operating conditions” is not implied. Exposure to absolute-maximum-rated conditions for extended periods may affect device reliability.

- NOTES: 1 The notation 10/1000 refers to a waveshape having $t_r = 10 \mu s$ and $t_w = 1000 \mu s$ ending at 50% of the peak value. The notation 10/160 is $t_r = 10 \mu s$ and $t_w = 160 \mu s$. The notation 2/10 is $t_r = 2 \mu s$ and $t_w = 10 \mu s$.
2. This value applies when the case temperature is at or below 85°C. The surge current may be repeated after the device has returned to thermal equilibrium.

DISSIPATION RATING TABLE

PACKAGE	$T_A \leq 25^\circ C$ POWER RATING	OPERATING FACTOR ABOVE $T_A = 25^\circ C$	$T_A = 85^\circ C$ POWER RATING
D	725 mW	5.8 mW/°C	377 mW
P	1000 mW	8.0 mW/°C	520 mW

TCM1030, TCM1050 DUAL TRANSIENT-VOLTAGE SUPPRESSORS

SCTS040B – JUNE 1989 – REVISED JUNE 1997

electrical characteristics over operating free-air temperature range (unless otherwise noted)

PARAMETER	TEST CONDITIONS	TCM1030			TCM1050			UNIT
		MIN	TYP†	MAX	MIN	TYP†	MAX	
V_{CF}	Forward clamping voltage (diode forward voltage) (see Note 3)	$I_{FM} = 1\text{-A transient}$	1.2	2	1.2	2	V	
		$I_{FM} = 10\text{-A transient}$	2.5	4	2	4		
		$I_{FM} = 16\text{-A transient}$	4	5	2.5	5		
		$I_{FM} = 30\text{-A transient}$	—	—	—	3.1		5
$V_{C(R)}$	Reverse clamping voltage (SCR on-state voltage) (see Note 3)	$I_{TM} = 1\text{-A transient}$	-1.2	-2	-1.2	-2	V	
		$I_{TM} = 10\text{-A transient}$	-2.5	-4	-2.5	-4		
		$I_{TM} = 16\text{-A transient}$	-4	-5	-3	-5		
		$I_{TM} = 30\text{-A transient}$	—	—	—	-4.8		-7
$I_{I(trip)}$	Trip current (see Note 4)	$V_S = -50\text{ V}$	-100	-325	-100	-325	mA	
I_H	Holding current	$V_S = -50\text{ V}$	-100		-150		mA	
$V_{I(trip)}$	Trip voltage	$V_S = -50\text{ V}, I = \text{trip current}$	-50	-55	-50	-55	V	
		$V_S = -65\text{ V}, I = \text{trip current}$	-65	-70	-65	-70		
		$V_S = -85\text{ V}, I = \text{trip current}$	—	—	—	-85		-90
$I_{I(stby)}$	Standby current	TIP and RING at -85 V or GND, $V_S = -85\text{ V}$		± 5		± 5	μA	
	Transient overshoot voltage	$V_S = -50\text{ V}, t_r = 10\text{ ns}$		2.5		2.5	V	
C_{off}	Off-state (high impedance) capacitance	TIP and RING at -50 V		25		25	pF	
		TIP and RING at GND		50		50		
dv/dt	Critical rate of rise of off-state voltage (see Note 5)	V_S open, $V_S = -50\text{ V}$		-1		-1	kV/ μs	

† All typical values are at $T_A = 25^\circ\text{C}$.

- NOTES:
3. The current flows through one TIP (or RING) terminal and one of the GND terminals. The voltage is measured between the other TIP (or RING) terminal and the other GND terminal. Measurement time $\leq 1\text{ ms}$.
 4. The negative value of trip current refers to the current flowing out of TIP or RING on the line side that is sufficient in magnitude to trigger the SCRs. Measurement time $\leq 1\text{ ns}$.
 5. The critical dv/dt is measured using a linear rate of rise with the maximum voltage limited to -50 V with V_S connected to TIP or RING being measured.

TCM1030, TCM1050 DUAL TRANSIENT-VOLTAGE SUPPRESSORS

SCTS040B – JUNE 1989 – REVISED JUNE 1997

TYPICAL CHARACTERISTICS

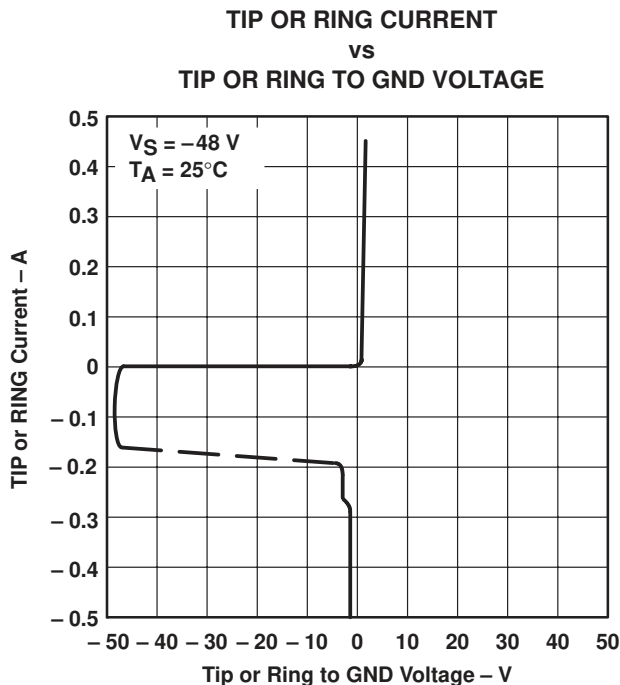

APPLICATION INFORMATION

The trip voltage represents the most negative level of stress applied to the system. Positive transients are clamped by diodes D1 and D2. When a negative transient is applied, current flows from V_S to TIP or RING where the transient voltage is applied. When the current through TIP or RING reaches the pulse-trip current, the SCR turns on and shorts TIP or RING to GND. The majority of the transient energy is dissipated in the external resistor (nominally $100\ \Omega$ for the TCM1030 and $70\ \Omega$ for the TCM1050). Current into V_S ceases when the SCR turns on. When the energy of the transient has been dissipated so that the current into TIP or RING due to the transient plus the battery feed supply is less than the holding current, the SCR turns off.

To help ensure reliability and consistency in the firing voltage, it is recommended that two capacitors be connected between V_S and GND, as close to the device terminals as possible. One capacitor should be a $0.1\text{-}\mu\text{F}$, 100-V ceramic unit and the other, a $0.47\text{-}\mu\text{F}$, 100-V stacked-film (not wound) metalized plastic capacitor. If inductance is present in the line to V_S , these capacitors help prevent overshoot in the firing voltage during fast rise-time transients.

To avoid dc latchup after the SCR has fired, the current must be less than the holding current, I_H . To prevent dc latchup, the line feed current must be limited to the following conditions:

$$\frac{V_{TP} - V_{RP}}{R_{line} + 2R_p} < I_H$$

where V_{TP} and V_{RP} are the voltages on TIP and RING, respectively, of the TCM1030 or TCM1050. Induced ac currents into TIP or RING (e.g., power-line inductive coupling) must be less than the trip current to prevent the SCR from firing.



POST OFFICE BOX 655303 • DALLAS, TEXAS 75265

APPLICATION INFORMATION

Line short-circuits to external power sources can damage the suppressor due to excessive power dissipation. Conventional protection techniques, such as fuses or PTC (positive temperature coefficient) thermistors, should be used to eliminate or reduce the fault current.

Figure 2 shows a typical line card application circuit.

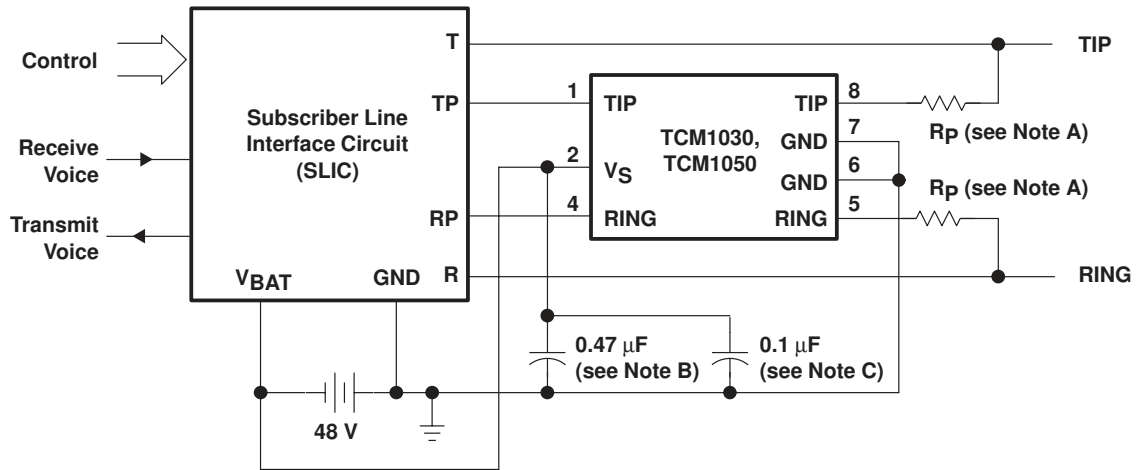

- NOTES: A. R_p is 100 Ω minimum for TCM1030 and 70 Ω minimum for TCM1050.
 B. 0.47 μF , 100 V stacked film metalized plastic capacitor
 C. 0.1 μF , 100 V ceramic capacitor

Figure 2. Typical Line Card Application Circuit

TCM1030, TCM1050 DUAL TRANSIENT-VOLTAGE SUPPRESSORS

SCTS040B – JUNE 1989 – REVISED JUNE 1997

MECHANICAL DATA

D (R-PDSO-G**)

PLASTIC SMALL-OUTLINE PACKAGE

14 PIN SHOWN

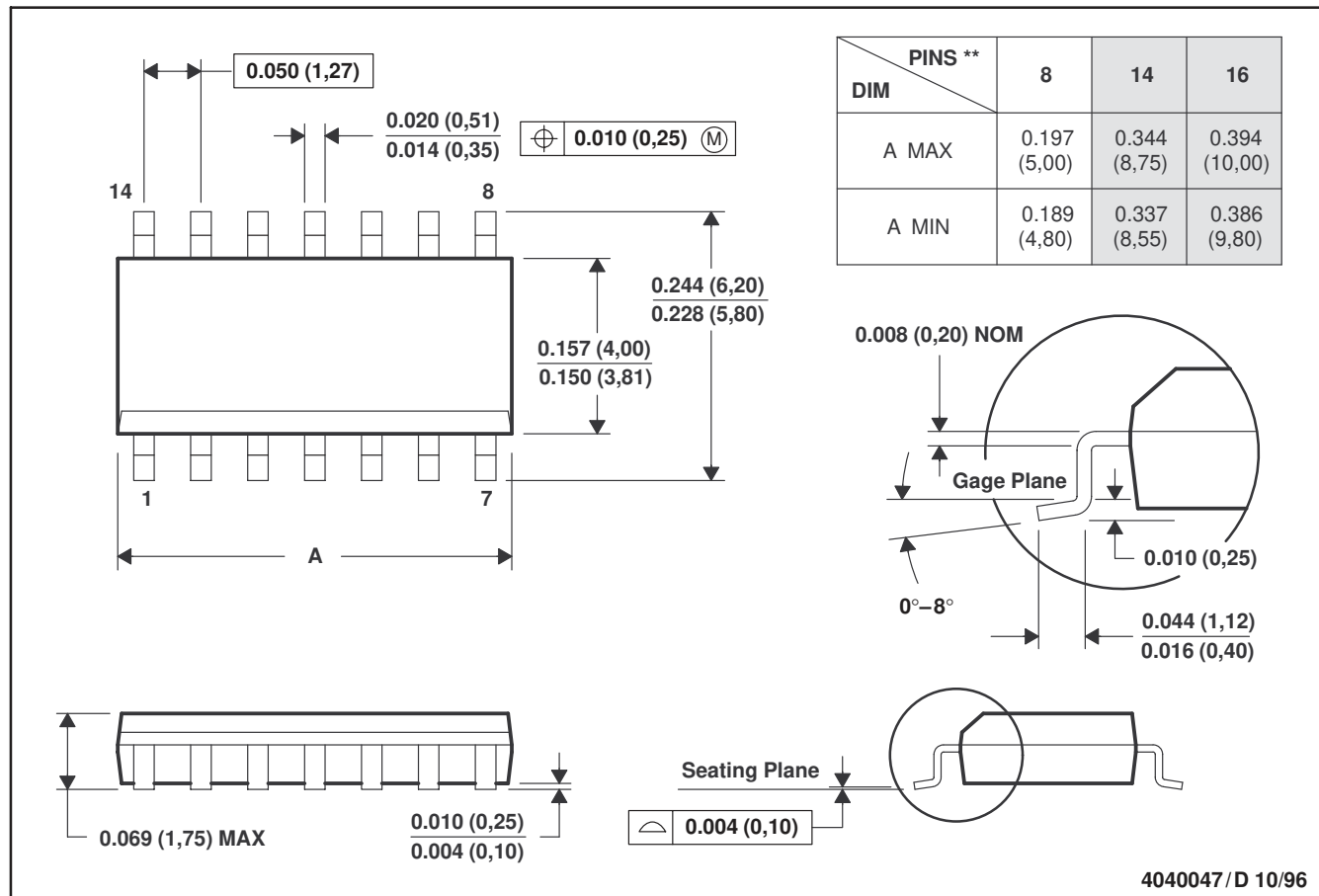

- NOTES: A. All linear dimensions are in inches (millimeters).
 B. This drawing is subject to change without notice.
 C. Body dimensions do not include mold flash or protrusion, not to exceed 0.006 (0,15).
 D. Falls within JEDEC MS-012

4040047 / D 10/96

MECHANICAL DATA

P (R-PDIP-T8)

PLASTIC DUAL-IN-LINE PACKAGE

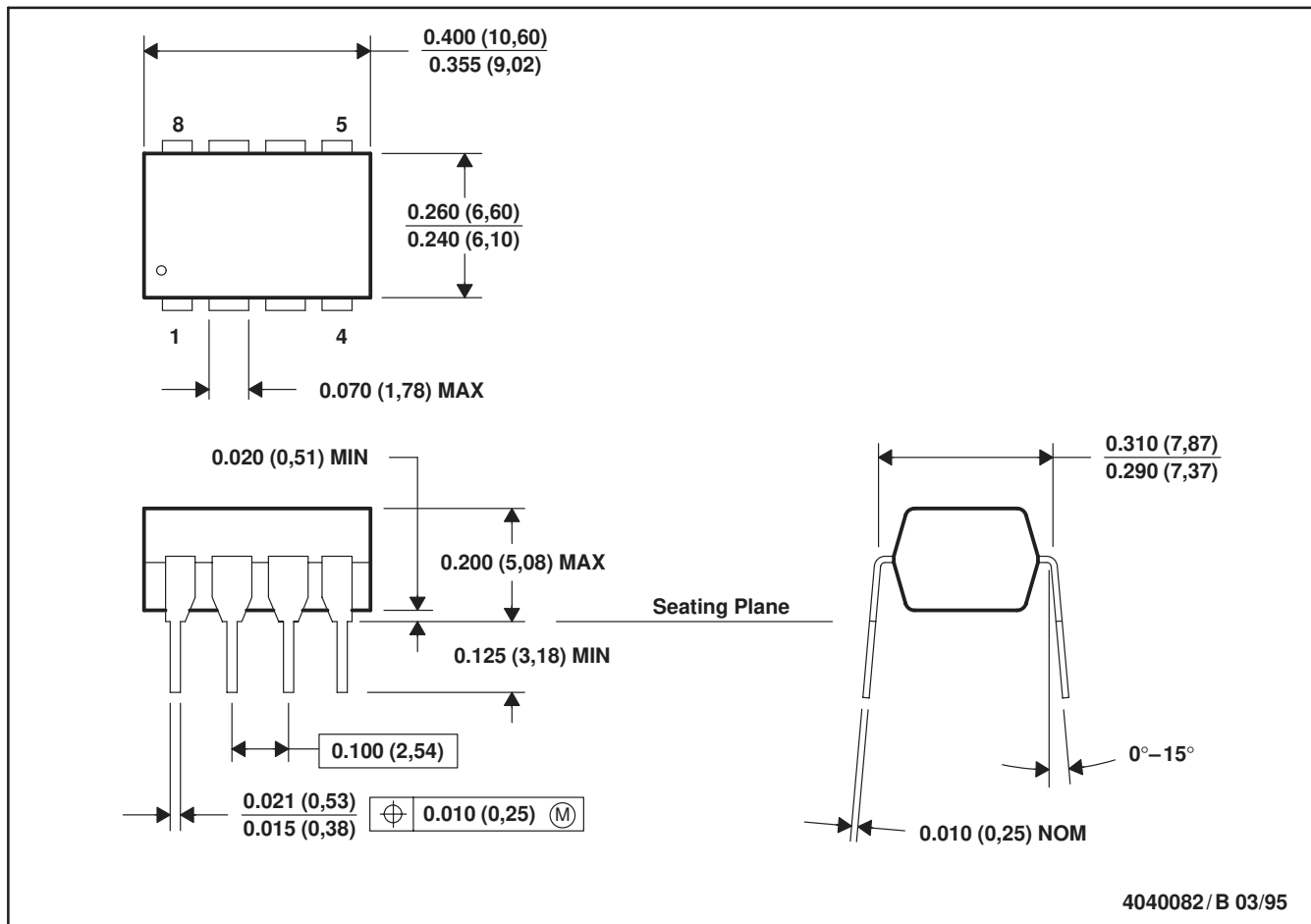

- NOTES: A. All linear dimensions are in inches (millimeters).
 B. This drawing is subject to change without notice.
 C. Falls within JEDEC MS-001

PRODUCT PREVIEW

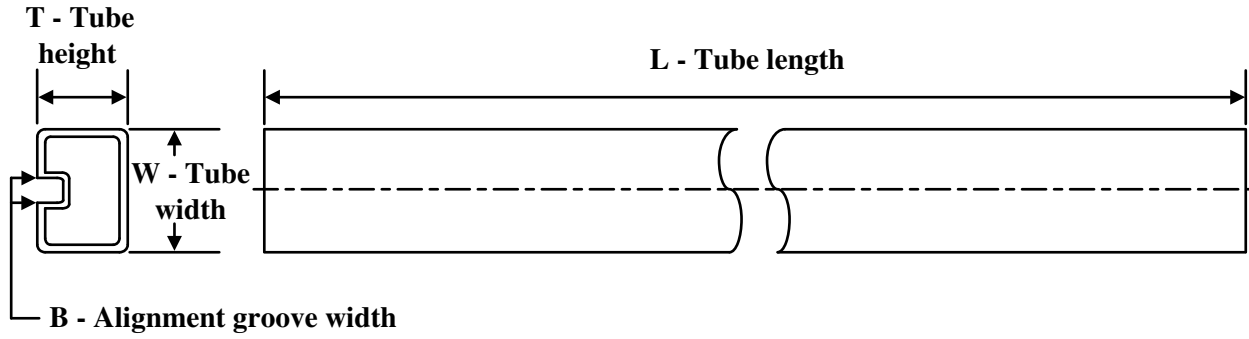
TUBE

*All dimensions are nominal

Device	Package Name	Package Type	Pins	SPQ	L (mm)	W (mm)	T (μm)	B (mm)
TCM1050D	D	SOIC	8	75	505.46	6.76	3810	4

IMPORTANT NOTICE AND DISCLAIMER

TI PROVIDES TECHNICAL AND RELIABILITY DATA (INCLUDING DATA SHEETS), DESIGN RESOURCES (INCLUDING REFERENCE DESIGNS), APPLICATION OR OTHER DESIGN ADVICE, WEB TOOLS, SAFETY INFORMATION, AND OTHER RESOURCES "AS IS" AND WITH ALL FAULTS, AND DISCLAIMS ALL WARRANTIES, EXPRESS AND IMPLIED, INCLUDING WITHOUT LIMITATION ANY IMPLIED WARRANTIES OF MERCHANTABILITY, FITNESS FOR A PARTICULAR PURPOSE OR NON-INFRINGEMENT OF THIRD PARTY INTELLECTUAL PROPERTY RIGHTS.

These resources are intended for skilled developers designing with TI products. You are solely responsible for (1) selecting the appropriate TI products for your application, (2) designing, validating and testing your application, and (3) ensuring your application meets applicable standards, and any other safety, security, regulatory or other requirements.

These resources are subject to change without notice. TI grants you permission to use these resources only for development of an application that uses the TI products described in the resource. Other reproduction and display of these resources is prohibited. No license is granted to any other TI intellectual property right or to any third party intellectual property right. TI disclaims responsibility for, and you will fully indemnify TI and its representatives against, any claims, damages, costs, losses, and liabilities arising out of your use of these resources.

TI's products are provided subject to [TI's Terms of Sale](#) or other applicable terms available either on [ti.com](https://www.ti.com) or provided in conjunction with such TI products. TI's provision of these resources does not expand or otherwise alter TI's applicable warranties or warranty disclaimers for TI products.

TI objects to and rejects any additional or different terms you may have proposed.

Mailing Address: Texas Instruments, Post Office Box 655303, Dallas, Texas 75265
Copyright © 2023, Texas Instruments Incorporated