

## Features

- 5 x 3 x 1.5 Inches Form factor
- Up to 550 Watts with Forced Air Cooled
- Efficiencies up to 92%
- -40 to 70 degree operating temperature\*
- 12V / 0.5A Fan Output
- Thermal Shut-Down feature
- Shall be approved to EN60601-1 3rd Edition
- Meets EN60601-1-2, 4<sup>th</sup> Edition
- Medical (BF) Safety Approvals
- MTBF : >3M hours as per Telcordia SR-332, issue 3

## Electrical Specifications

Input Voltage	90-264 VAC/390 VDC, Universal (Derate from 100% at 115VAC to 78% at 90VAC)	
Input Frequency	47-63 Hz	
Input Current	115 VAC: 6.0 A max.	230 VAC: 3.0 A max.
No Load Power	< 0.5W @ 115VAC	< 0.7W @ 230VAC
Inrush Current	115 VAC – 25 A, 230 VAC – 45 A, 264 VAC – 75 A	
Leakage Current	<200uA @115VAC and <400uA @230VAC	Touch current <100uA
Efficiency	92%(48V), 91%(24V), 90%(12V,15V) typical @ 230VAC full load	
Hold-up Time	Full Load > 16 ms typical	Convection Load > 55 ms typical    Conduction Load > 30ms typical
Power Factor	exceeds 0.95 with Full Load	
Output Power	up to 550W (Forced Air Cooled) up to 250W (Conduction Cooled) up to 150W (Convection Cooled)	
Output Voltage Adjustability	+/-3%	
Line Regulation	+/-0.5%	
Load Regulation	+/-1%	
Transient Response	50-100% step load change, at 0.1A/uS slew rate, 50% duty cycle, 50Hz=5% , recovery time < 5 ms	
Rise Time	55 ms typical	
Set Point Tolerance	+/-1%	
Over Current Protection	>110%, Hiccup mode / Auto Recovery	
Over Voltage Protection	110 to 140%, Hiccup mode / Auto Recovery	
Short Circuit Protection	Hiccup mode / Auto Recovery	
Switching Frequency	PFC – 70 to 130 KHz ,Resonant – 68 to 80 KHz	
Operating Temperature	-40 to +70°C, * -40 to 0°C startup is guaranteed with spec deviation ( ref note 6)	
Storage Temperature	-40 to +85°C	
Relative Humidity	5% to 95%, noncondensing	
Altitude	Operating: 16,000 ft.; Nonoperating: 40,000 ft.	
Isolation Voltage	Input to Output – 4000 VAC medical applications. Input to GND - 1500 VAC , Output to GND- 1500VAC for type BF , 500 VAC for type B	

Model Number	Voltage	Max. Load (Convection)	Max. Load <sup>7</sup> (Conduction)	Max. Load (400 LFM)	Min. Load	Ripple <sup>1</sup>
MWLC550-1012	12V	9.17A	16.67A	41.67A	0.0A	2%
MWLC550-1015	15V	7.33A	13.33A	33.33A	0.0A	2%
MWLC550-1024	24V	6.25A	10.42A	22.92A	0.0A	1%
MWLC550-1030	30V	5.00A	8.33A	18.33A	0.0A	1%
MWLC550-1048	48V	3.13A	5.21A	11.46A	0.0A	1%
MWLC550-1058	58V	2.59A	4.31A	9.48A	0.0A	1%

Connectors		
J1	Pin 1	AC LINE
	Pin 2	NOT FITTED
	Pin 3	AC NEUTRAL
J2	Pin 1	V1 +VE
	Pin 2	V1 -VE
J3	Pin 1	FAN +VE
	Pin 2	FAN -VE

## Notes

1. Ripple is peak to peak with 20 MHz bandwidth and 10  $\mu$ F (Electrolytic capacitor) in parallel with a 0.1  $\mu$ F capacitor at rated line voltage and load ranges.
2. Combined output power of main output, fan supply shall not exceed max. Power rating.
3. Fan supply output voltage tolerance including set point accuracy, line and load regulation is +/-10% and Ripple and noise is less than 10%.
4. Specifications are for nominal input voltage, 25°C unless otherwise stated.
5. Thermal shutdown feature : The power supply goes in hiccup mode when the temperature of Substrate PCB exceeds 110 °C (+/-10 °C).
6. Output ripple can be more than 10% of the output voltage.
7. Refer Recommended Conduction Plate & Clearance on Page No. 6



Innovations in Power

## Mechanical Specifications

AC Input Connector (J1)	JST : B3P-VH-B(LF)(SN) or equivalent Mating: VHR-3M or equivalent Pins : SVH-41T-P1.1 or equivalent
Earth (J4)	Molex: 19705-4301 Mating: 19003-0001
DC Output Connector (J2) (Screw Terminal)	6-32 inches Screw Pan HD Mating: Designed to accept Ring Tongue Terminal AMP : 8-31886-1, wherein one 16 AWG(max) wire can be crimped. Note : One Ring Tongue Terminal with 16 AWG is recommended for current up to 11A only. Use multiple tongue terminals with wire for more current
Aux (Fan) Output(J3)	AMP :640456-2 Mating: 640440-2
Dimensions	5 x 3 x 1.5 inches (127 x 76.2x 38.1 mm)
Weight	500 gm approx

## EMC

Parameter	Conditions/Description	Criteria
Conducted Emissions	EN 55011-B,CISPR22-B, FCC PART15-B	Pass
Radiated Emissions	EN 55011 A	Pass Level B with external core (King core K5B RC 25x12x15-M in input cable)
Input Current Harmonics	EN 61000-3-2	Class D
Voltage Fluctuation and Flicker	EN 61000-3-3	Pass
ESD Immunity	EN 61000-4-2	Level 4, Criterion A
Radiated Field Immunity	EN 61000-4-3	Level 3, Criterion A
Electrical Fast Transient Immunity	EN 61000-4-4	Level 3, Criterion A
Surge Immunity	EN 61000-4-5	Level 3, Criterion A
Conducted Immunity	EN 61000-4-6	Level 3, Criterion A
Magnetic Field Immunity	EN 61000-4-8	Level 4, Criterion A
Voltage dips, interruptions	EN 61000-4-11	Criterion B

## Safety

CE Mark	Complies with LVD Directive
Approval Agency	Nemko, UL, C-UL
Safety Standard(s)	UL /CSA : ANSI/AAMI ES60601-1 (2005 + C1:09 + A2:10) AMD1:2012; CORR1:2009; AMD2:2010, (/ CAN/CSA-C22.2 No. 60601-1 (2008)CAN/CSA C22.2 No. 60601-1:14 IEC : IEC 60601-1: 2005 + CORR. 1:2006 + CORR. 2:2007 + AM1:2012(or IEC 60601-1: 2012 reprint) EN : EN 60601-1:2006;A1
Safety File Number(s)	UL Certificate No : E173812 CB Test Certificate No : NO93054 Nemko Certificate No : P16221240

## Derating Curve

### Power De-rating : w.r.t. Input For all mounting options a to f

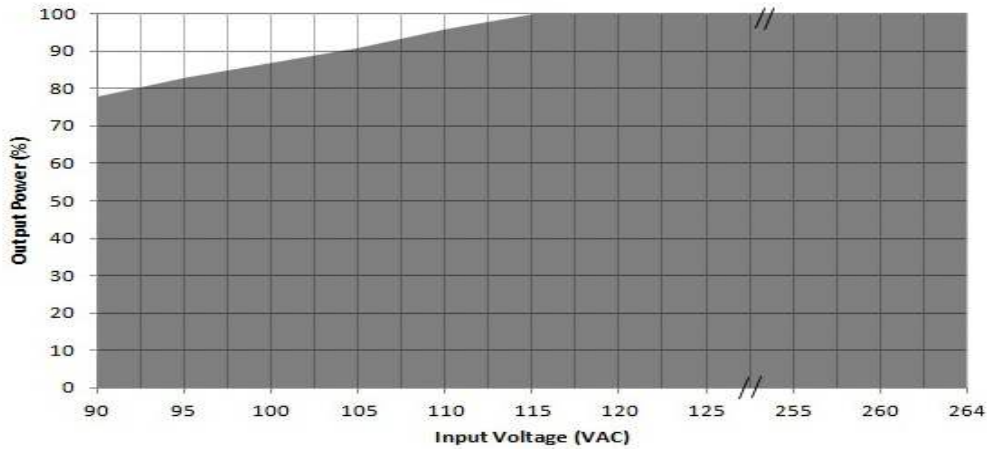

De-rate linearly from 100% at 115VAC to 78% at 90VAC

### Power De-rating : 12V, 15V For all mounting options a to f

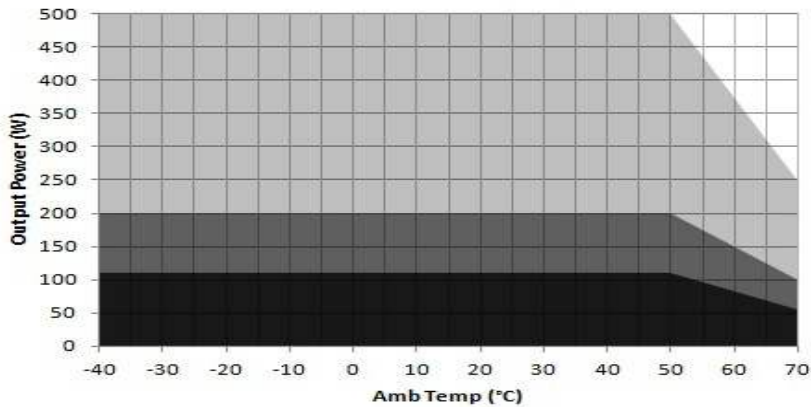

Convection load: 110W up to 50 °C  
De-rate above 50 °C @ 2.5% per °C

Conduction load: 200W up to 50 °C  
De-rate above 50 °C @ 2.5% per °C

Forced air cooled load : 500W up to 50°C  
De-rate above 50 °C @ 2.5% per °C

### Power De-rating : 24V, 30V, 48V, 58V For all mounting options a to f

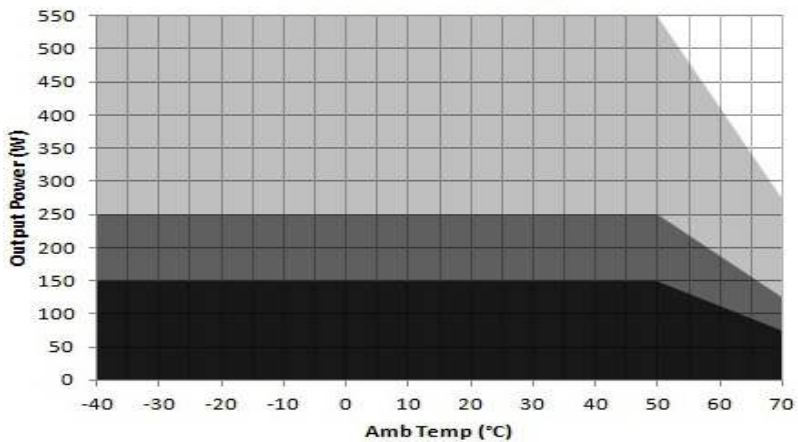

Convection load: 150W up to 50 °C  
De-rate above 50 °C @ 2.5% per °C

Conduction load: 250W up to 50 °C  
De-rate above 50 °C @ 2.5% per °C

Forced air cooled load : 550W up to 50°C  
De-rate above 50 °C @ 2.5% per °C



Innovations in Power

## Maximum Operating Temperature

For reliable and safe operation, please make sure the maximum component temperatures given in table below is not exceeded.

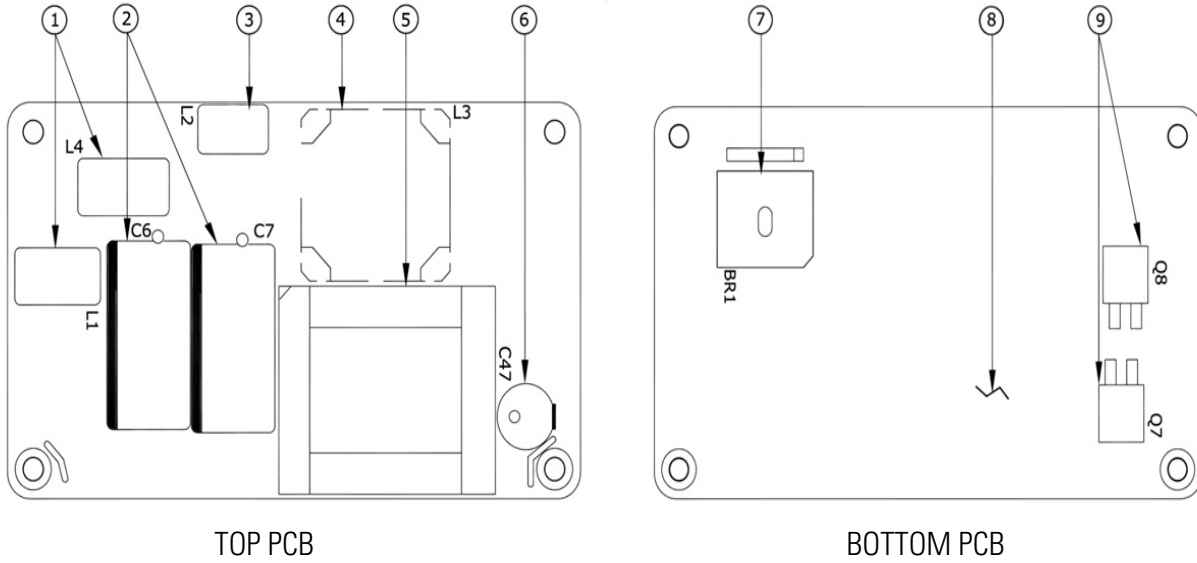

Ident no	Description	Max Temp Allowed (°C)
1	Common mode chokes	95
2	Input Bulk Capacitors	90
3	Differential choke	110
4	Boost Choke	110
5	Output Transformer	125 (for 12V & 15V) 110 (for 24V,30V,48V,58V)
6	Output Capacitor	90
7	Bridge Rectifier	120
8	Aluminium Clad PCB	105
9	Output Rectifiers	110

## Recommended Conduction Plate & Clearance

Conduction power rating mentioned in the table is with additional aluminium base plate of 3 mm thickness with 177.8mm(7in) length & 101.6mm(4in) width.

Clearance of minimum 15mm above the component height is recommended for better thermal management.

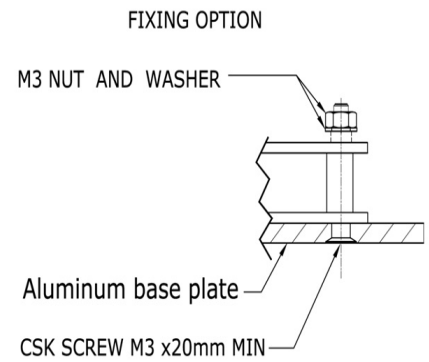
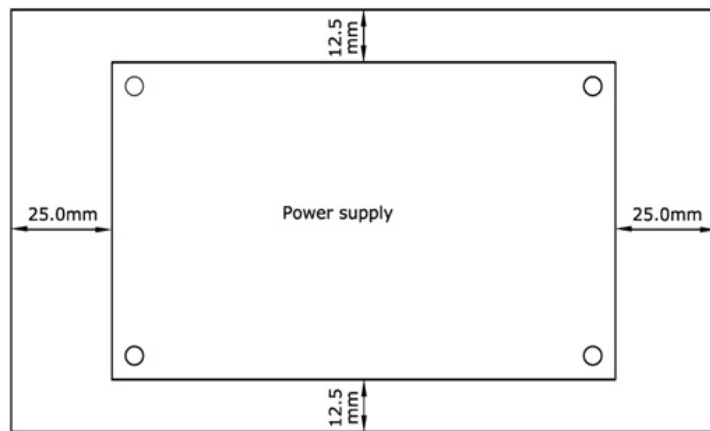
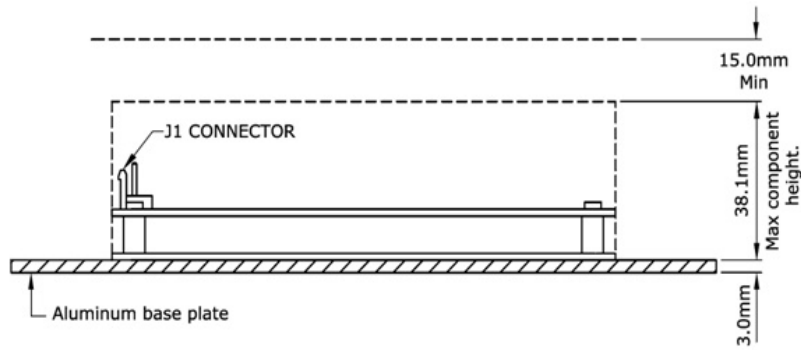

## Mounting Option

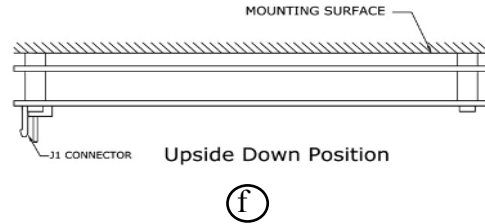
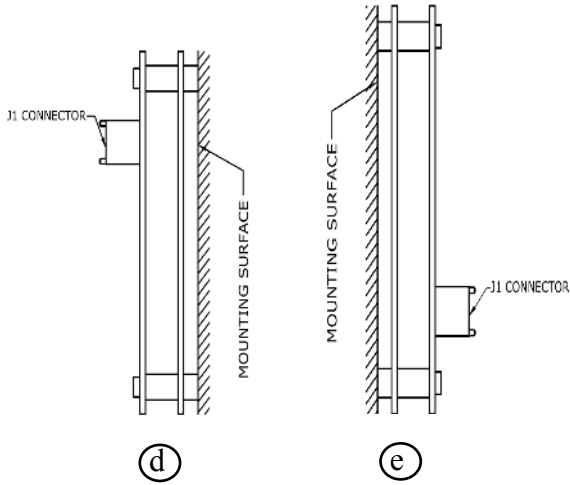
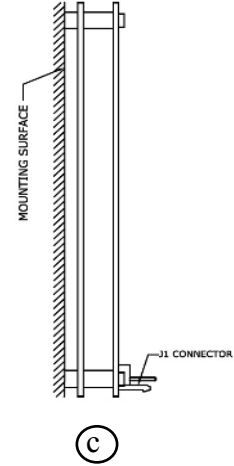
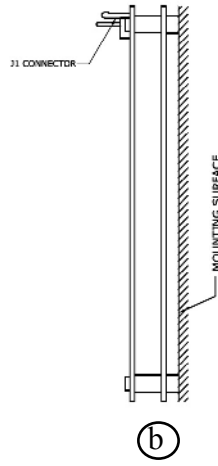
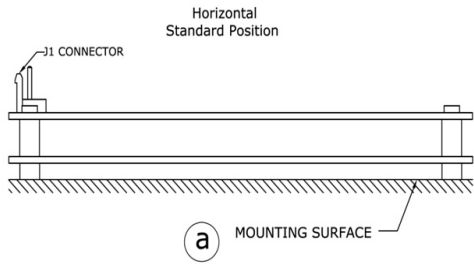

### FIXING OPTION - 1

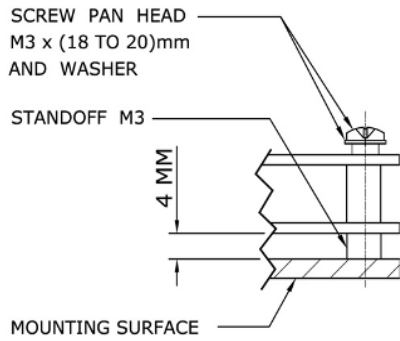

### FIXING OPTION - 2

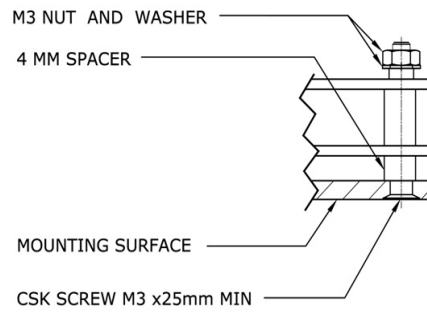

# Mechanical Drawing

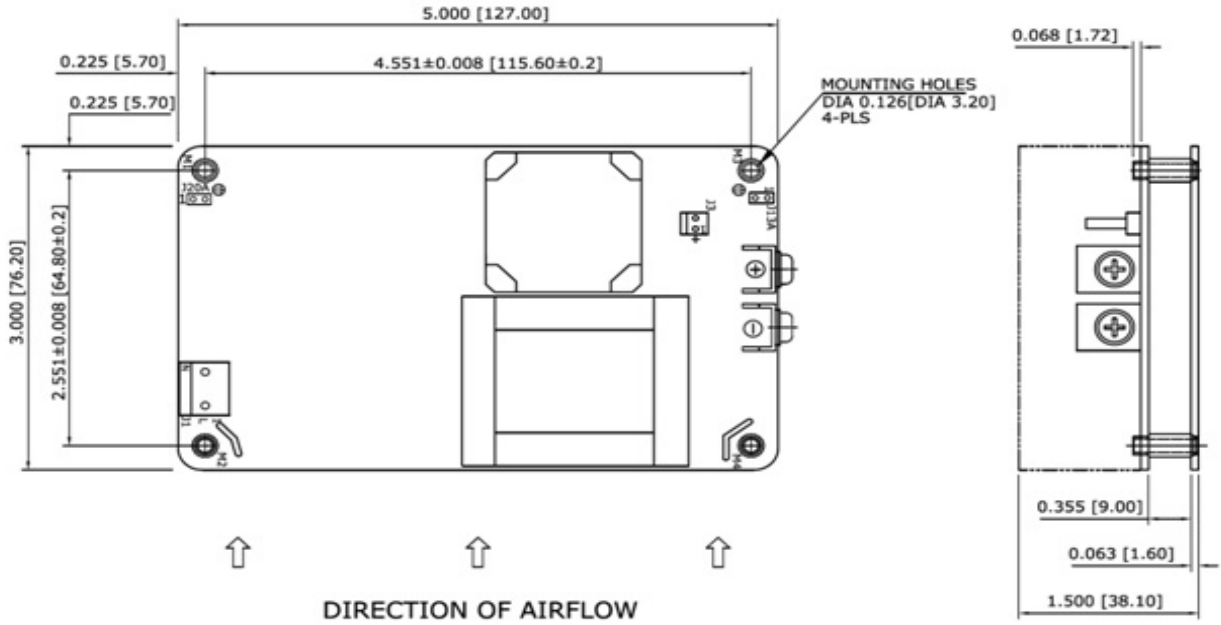

MECHANICAL OUTLINE DIMENSIONS  
ALL DIMENSIONS ARE IN INCHES[MM]  
GEN TOLERANCE : +/-0.04[+/-1.0MM]



Innovations in Power