

**MARKETING SALES DRAWING**  
 DIMENSIONS IN INCHES - DO NOT SCALE THIS DRAWING  
 DIMENSIONS IN METRIC - [ ]

Electrical Testing  
 per Tusonix standard  
 test plans and Mil-Std-202  
 Test Methods.

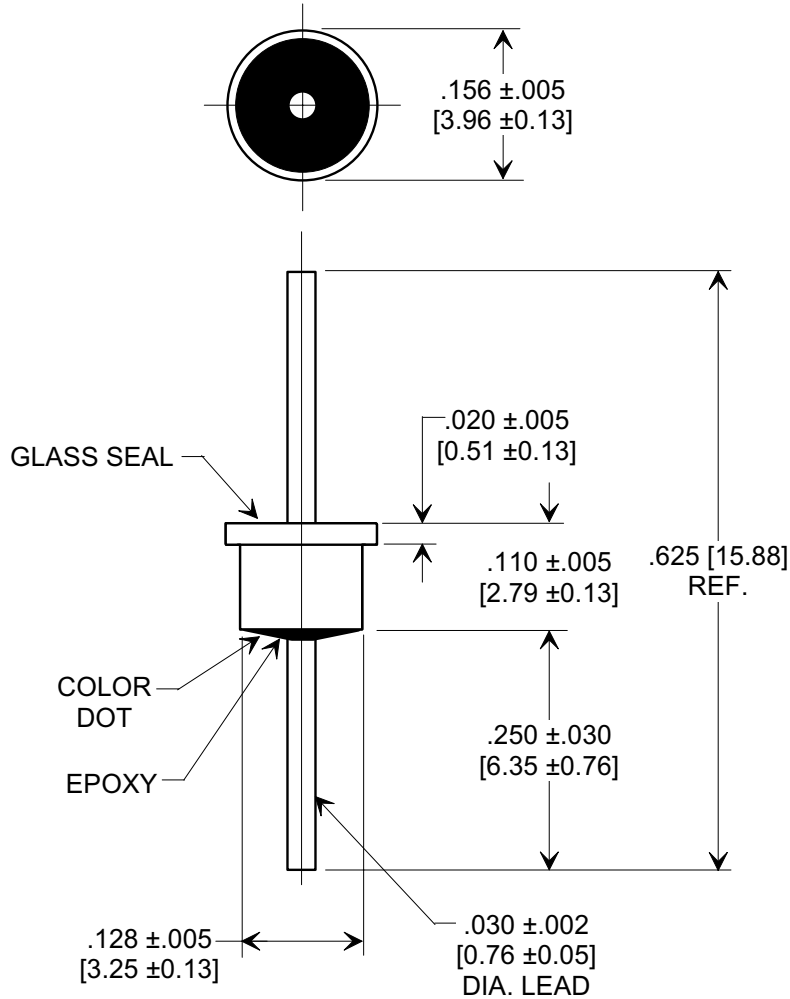
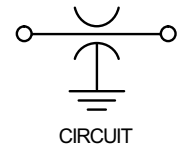
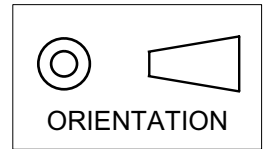

**NOTES:**

1. Operating temperature range: -55°C to +125°C.
2. Gold plated case and lead.
3. Epoxy sealed on opposite end from glass seal.
4. Max. recommended soldering temperature: 260°C.  
See installation recommendations.
5. Recommended mounting hole: .135 dia.
6. Solder preform available for mounting.
7. Tusonix Standard part number: 4300-020.  
Tusonix RoHS compliant part number: 4300-020 LF.  
Customer must specify Standard or RoHS part number when ordering.
8. RoHS compliant part marked with additional dark green dot for identification.

Cx (pF)	TOL.	DC WORKING VOLTAGE		I.R. MIN. @ 100 (VDC.)	DWV (VDC)	DC CURRENT (AMPS)	MIN. NO LOAD INSERTION LOSS (dB) @ 25° C PER MIL-STD-220					COLOR CODE
		85°C	125°C				1 MHz	10 MHz	100 MHz	1 GHz	10 GHz	
100	GMV	300	200	10 G	500	5	---	----	3	20	28	GREEN

<b>REVISION RECORD</b>	Original Release C.O. <b>5261</b>	<b>0</b>
	VARS 025, 026, 027 & 1MHz COLUMN ADDED. L.E. 11-07-90	
	<b>5591</b> VARS 681 WAS 030 & VAR 031 ADDED. L.E. 06-10-91	
	<b>5966</b> RDN TO COMP FMP. STYLE DWG SPLIT FOR EACH VAR. S.M. 10-02-02	
<b>20021001-8-01</b> ADDED NOTES 7 & 8. S.M. 05-23-05	<b>3</b>	
<b>20050511-2-21</b>		

--TOLERANCES-- Unless Otherwise Specified		Title <b>SOLDER MOUNT EMI FILTER</b>	
DECIMAL ± NOTED			
ANGLES ±		Drawn S.M. 10-02-02	Scale 5 X
<b>TUSONIX</b> TUCSON, ARIZONA		Approved T.C. 10-02-02	
		<b>A</b>	<b>4300-020</b>

X-2015 Rev-0