

ISL8272MEVAL2Z

Evaluation Board User Guide

UG004
Rev 0.00
October 20, 2014

Description

The ISL8272M is a 50A step-down DC/DC power supply module with an integrated digital PWM controller, dual-phase synchronous power switches, inductors and passives. Only input, output capacitors and minimal passives are needed to finish the design. 50A of continuous output current can be delivered without a need of airflow or heatsink. The ISL8272M uses ChargeMode™ control (ASCR) architecture, which responds to a transient load within a single switching cycle.

The ISL8272MEVAL2Z evaluation board has three ISL8272M modules connected in a current sharing configuration to deliver 150A continuous output current. This evaluation board comes with placeholders for pin-strap resistor to adjust output voltage, soft-start timing, input UVLO threshold, control loop response, current sharing configurations, and device PMBus™ address. More configurations, such as Digital-DC™ (DDC) bus configuration and fault limits can be easily programmed or changed via PMBus compliant serial bus interface.

ZLUSBEVAL3Z (USB to PMBus adapter) is provided with this evaluation kit, which connects the evaluation board to a PC to activate the PMBus communication interface. The PMBus command set is accessed by using the PowerNavigator™ evaluation software from a PC running Microsoft Windows.

References

[ISL8272M](#) datasheet

Key Features

- V_{IN} range of 4.5V to 14V, V_{OUT} adjustable from 0.6V to 5V
- Programmable V_{OUT} , V_{OUT} droop, margining, input and output UVP/OVP, I_{OUT} limit, OTP/UTP, soft-start, sequencing, and external synchronization
- Monitor: V_{IN} , V_{OUT} , I_{OUT} , temperature, duty cycle, switching frequency and faults
- ChargeMode™ control tunable with PMBus
- Output FETs for load transient response evaluation
- Mechanical switch for enable and power-good LED indicator

Specifications

This board has been configured for the following operating conditions by default:

- $V_{IN} = 5V$ TO 12V
- $V_{OUT} = 1.2V$
- $I_{MAX} = 150A$
- $f_{SW} = 421kHz$
- 3-module current sharing with 0.1mV/A V_{OUT} droop
- Output ripple: <5mV_{p-p}
- ASCR gain = 200, ASCR residual = 90
- Soft-start delay = 5ms; soft-start ramp time = 4ms

Ordering Information

PART NUMBER	DESCRIPTION
ISL8272MEVAL2Z	ISL8272M Kit (Evaluation Board, ZLUSBEVAL3Z Adapter, USB Cable)

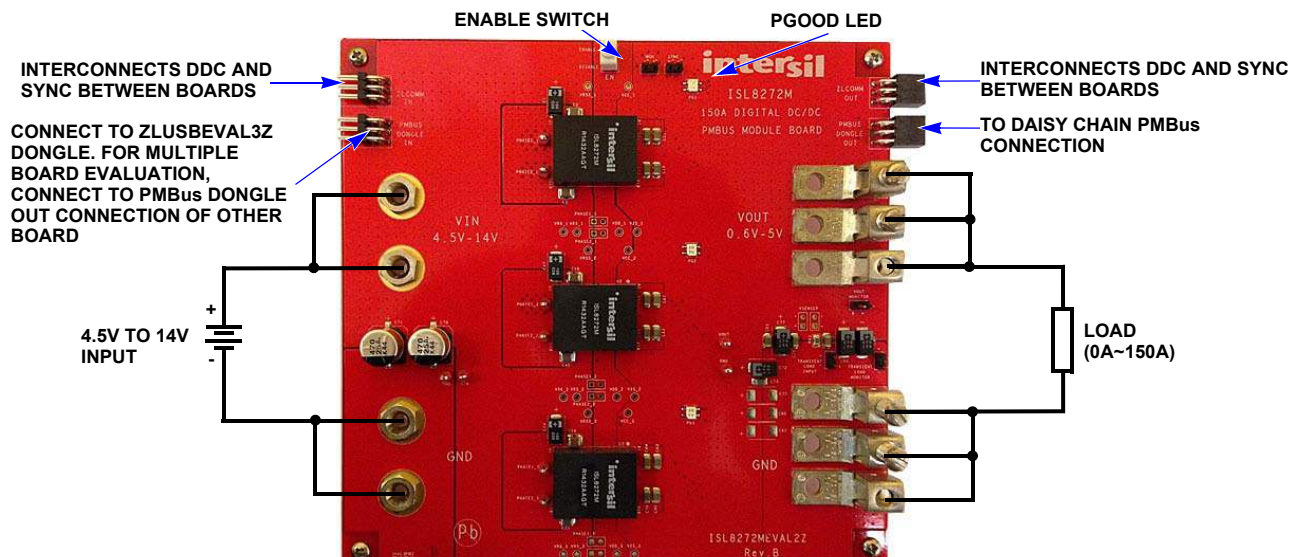

FIGURE 1. TOP VIEW - ISL8272MEVAL2Z EVALUATION BOARD

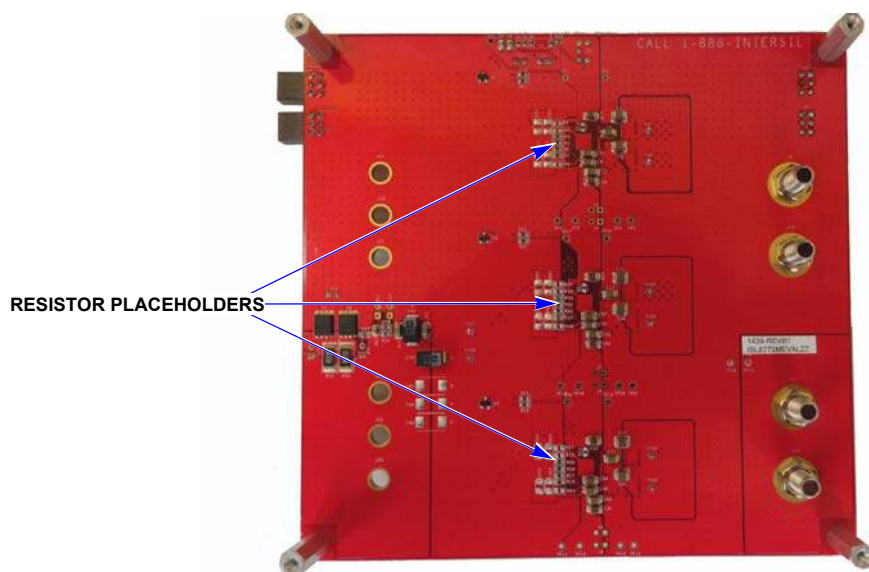

FIGURE 2. BOTTOM VIEW - ISL8272MEVAL2Z EVALUATION BOARD

Recommended Equipment

- DC power supply with minimum 15V/40A sourcing capacity
- Electronic load capable of sinking current up to 150A
- Digital multimeters (DMMs)
- Oscilloscope with bandwidth higher than 100MHz

Functional Description

The ISL8272MEVAL2Z provides all circuitry required to evaluate the current sharing features of the ISL8272M. A majority of the features of the ISL8272M, such as compensation-free ChargeMode™ control, soft-start delay and ramp times and voltage margining are available on this evaluation board. For DDC communication evaluation, the board can be connected to any Intersil digital module evaluation board that supports the DDC bus.

Figures 1 and 2 show the board images of the ISL8272MEVAL2Z evaluation board.

Quick Start Guide

Pin-Strap Option

ISL8272MEVAL2Z can be configured in pin-strap mode with standard 1% 0603 resistors. PMBus interface is not required to evaluate ISL8272M in pin-strap mode. Output voltage (V_{OUT}), soft-start timing, input undervoltage protection (UVLO) threshold, ASCR gain and residual, current sharing configuration and device PMBus address can be changed by populating recommended resistors at placeholders provided in the evaluation board. By default, the evaluation board operates in pin-strap mode and regulates at $V_{OUT} = 1.2V$, $f_{SW} = 421kHz$, soft-start delay time = 5ms, soft-start ramp time = 4ms, UVLO = 4.5V, ASCR gain = 200, ASCR residual = 90 and PMBus address = 2Ah, 2Bh, 2Ch. In addition, the three modules are pin strapped for current sharing, with a V_{OUT} droop of 0.1mV/A. Follow these steps to evaluate ISL8272M in pin-strap mode.

1. Set ENABLE switch to "DISABLE".
2. Connect Load to VOUT lug connectors (J19, J21, J23 and J20, J22, J25).
3. Connect power supply to VIN connectors (J9, J10 and J11, J12). Make sure power supply is not enabled when making connection.
4. Turn power supply on.
5. Set ENABLE switch to "ENABLE".
6. Measure 1.2V VOUT at probe point labeled "VOUT MONITOR" (J24).
7. Observe switching frequency of 421kHz and phase spreading at probe points labeled "PHASE1_1" (TP7), "PHASE2_1" (TP8), "PHASE1_2" (TP23), "PHASE2_2" (TP24), "PHASE1_3" (TP15), "PHASE2_3" (TP16).
8. To measure the board efficiency, connect the multimeter voltage probes at probe points labeled "VIN" (TP26), "GND" (TP25) and "VOUT" (TP27), "GND" (TP28).
9. To change VOUT, disconnect board from the setup and populate 1% standard 0603 resistors at R4, R34 and R19 placeholder locations on the bottom layer. Refer to the "Output Voltage Resistor Settings" table in the [ISL8272M](#) datasheet for recommended values. By default, VOUT_MAX is set to 110% of VOUT set by pin-strap resistor. Keep in mind that modules in the same current sharing group must have identical VSET pin-strap resistors. For higher output voltage setting, VOUT droop must be increased proportionally to ensure good current sharing.
10. To change soft-start delay and ramp time, disconnect board from the setup and populate 1% standard 0603 resistors at R6, R36 and R21 placeholder locations on the bottom layer. Refer to the "Soft Start/Stop Resistor Settings" table in the [ISL8272M](#) datasheet for recommended values. Notice that only immediate off is supported in current sharing configuration.
11. To change UVLO, disconnect board from the setup and populate standard 0603 resistors at R6, R36 and R21

placeholder locations on the bottom layer. Refer to the “UVLO Resistor Settings” table in the [ISL8272M](#) datasheet for recommended values. Notice that the UVLO programming shares the same pin with soft-start/stop programming.

12. To change ASCR gain and residual, disconnect board from the setup and populate 1% standard 0603 resistors at R8, R38 and R23 placeholder locations on the bottom layer. Refer to the “ASCR Resistor Settings” table and the design guide matrix in the [ISL8272M](#) datasheet for recommended values. Modules in the same current sharing group must have identical ASCR gain and residuals.
13. To change current sharing configuration, disconnect board from the setup and replace with 1% standard 0603 resistors at R5, R35 and R20 on the bottom layer. Refer to the “Current Sharing Resistor Settings” table in the [ISL8272M](#) datasheet for recommended values. For example, using 12.1k for R5, 13.3k for R35 and OPEN for R20 will configure two modules for current sharing (with a VOUT droop of 0.15mV/A) and the third module as stand alone.

PMBus Option

ISL8272MEVAL2Z can be evaluated for all features particularly in the current sharing configuration using the provided ZLUSBEVAL3Z dongle and PowerNavigator™ evaluation software. Follow these steps to evaluate ISL8272M with PMBus option.

1. Install the PowerNavigator™ evaluation software from the following Intersil website: www.intersil.com/powernavigator
2. Set ENABLE switch to “DISABLE”.
3. Connect Load to VOUT lug connectors (J19, J21, J23 and J20, J22, J25).
4. Connect power supply to VIN connectors (J9, J10 and J11, J12). Make sure power supply is not enabled when making connection.
5. Turn power supply on.
6. Connect ZLUSBEVAL3Z dongle (USB to PMBus™ adapter) to ISL8272MEVAL2Z board to the 6-pin male connector labeled as “PMBus DONGLE IN”.
7. Connect supplied USB cable from computer USB to ZLUSBEVAL3Z dongle.
8. Launch PowerNavigator™ software.
9. It is optional to load a predefined setup from three separate configuration files using the PowerNavigator™ software. The three ISL8272M devices on the board operate in pin-strap mode from factory default, but the user may modify the operating parameters through the evaluation software or by loading a predefined setup from configuration files. A sample set of the “Configuration File” beginning on [page 11](#) is provided and can be copied to a notepad editor to make desired changes. The default pin-strap configurations will be overwritten if user-defined configuration files are loaded.
10. Set ENABLE switch to “ENABLE”. Alternately, the PMBus commands ON_OFF_CONFIG and OPERATION may be used from the PowerNavigator™ software to allow PMBus Enable.
11. Monitor and configure the ISL8272MEVAL2Z board using the PMBus commands in the evaluation software. To store the configuration changes, disable the module and use the command STORE_USER_ALL. To restore factory default settings, disable the module and use the command RESTORE_FACTORY and STORE_USER_ALL.
12. PowerNavigator™ tutorial videos are available at Intersil website. www.intersil.com/powernavigator
13. To evaluate multiple Intersil digital power products using a single ZLUSBEVAL3Z dongle, ISL8272M can be daisy chained with other digital power evaluation boards. PMBus address can be changed by replacing with 1% standard 0603 resistors at R3, R33 and R18 locations on the bottom layer. Refer to the “SMBus Address Resistor Selection” table in the [ISL8272M](#) datasheet for recommended values.

Evaluation Board Information

The evaluation board size is 5.8in x 6.1in. It is a 6-layer board, containing 2-ounce copper on all layers. The board can be used as a 150A reference design. Refer to the “[ISL8272MEVAL2Z Evaluation Board Layout](#)” beginning on [page 13](#). The board is made of FR4 material and all components, including the solder attachment, are lead-free.

VOUT Transient Response Measurement

The ISL8272MEVAL2Z board has a built-in transient load test circuitry (see the schematic in [Figure 3](#)). Two 100A N-Channel MOSFETs (Manufacturer PN: BSC010NE2LS) are connected in parallel across VOUT and PGND next to the remote voltage sensing location (C98). Two 10mΩ current sense resistors connected in parallel are placed for monitoring the drain-to-source current of the MOSFETs. For a transient load test, inject the gate driver pulse signal at J16, which is labeled as “TRANSIENT LOAD INPUT.” The load current can be monitored through J15, which is labeled as “TRANSIENT LOAD MONITOR.” Because the two MOSFETs will operate in the saturation region instead of linear region when the gate turn-on signal is applied, the pulse width and duty cycle of the gate signal must be sufficiently small to avoid MOSFETs overheating (recommended duty cycle should be less than 2% to 3%). The amplitude of the gate driver pulse voltage can be adjusted to obtain a desired transient load current step size.

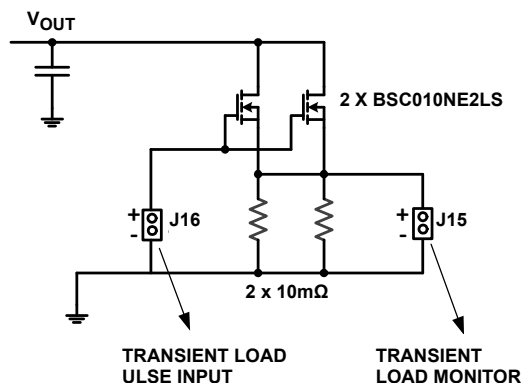

FIGURE 3. SCHEMATIC FOR TRANSIENT LOAD MEASUREMENT

Control Loop Bode Plot Measurement

To measure the bode plot of the voltage control loop, the first step is to break the loop such that a small signal with variable frequency can be injected at a certain point. On this ISL8272MEVAL2Z evaluation board, the 0 Ω resistor R58 placed in the VOUT remote sense line can be replaced by a 5 Ω ~10 Ω resistor. The placeholders J17 and J18 can be used to inject the frequency-sweep signal across R58 from a network analyzer. Connect the network analyzer input (Channel A) at J17 and output (Channel B) at J18 to measure the voltage loop transfer function and frequency responses. See the configuration diagram in [Figure 4](#).

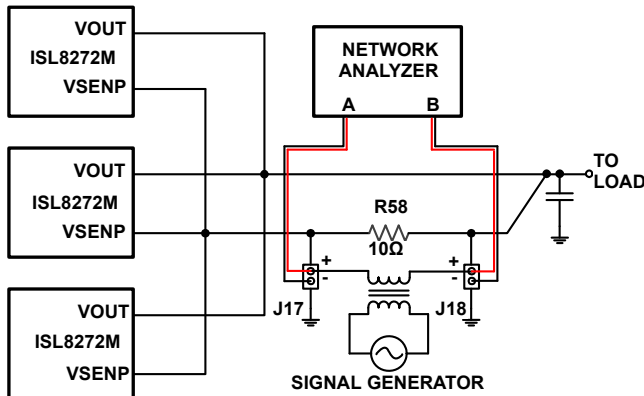

FIGURE 4. CONFIGURATION FOR VOLTAGE LOOP BODE PLOT MEASUREMENT

Thermal Considerations and Current Derating

Board layout is very critical in order to make the module operate safely and deliver maximum allowable power. To work in the high temperature environments and carry large currents, the board layout needs to be carefully designed to maximize thermal performance. To achieve this, select enough trace width, copper weight and the proper connectors.

The ISL8272MEVAL2Z evaluation board is designed for running 150A at room temperature under default configurations without additional cooling. However, if the output voltage is increased or the board is operated at elevated temperatures, then the available output current is derated. Typically, the module temperatures is higher on the current sharing board compared to the single-module board under the same operating conditions due to the limited PCB copper planes for heat sink. For single-module operation, refer to the derated current curves in the [ISL8272M](#) datasheet to determine the maximum output current the module can supply. θ_{JA} is measured by inserting a thermocouple inside the module to measure peak junction temperature.

For layout of current sharing designs using the ISL8272M, the thermal performance can be improved by adhering to the following design tips:

1. Use the top and bottom layers to carry the large current. One or more inner layers can also be used to carry the large current if available. VOUT, PGND and VIN pads should have large, solid planes. Place enough thermal vias to connect the power planes in different layers under and around the modules.
2. SW1 and SW2 pads are switching nodes that generate switching noises. Keep these pads under the module. For noise-sensitive applications, it is recommended to keep switching node pads only on the top and inner layers of the PCB; do not place switching node pads exposed to the outside on the bottom layer of the PCB. To improve the thermal performance, the switching node pads can be extended in the inner layer (Layer 3 on this board), as shown on the [“ISL8272MEVAL2Z Evaluation Board Layout” beginning on page 13](#). Make sure that Layer 2 and Layer 4 have the GND planes to cover the extended areas of the switching node pads at Layer 3 to avoid noise coupling.
3. To create a low impedance path for the high frequency inductor ripple current, output ceramic capacitors must be placed very close to the center of the module VOUT pads. Therefore, multiple vias must be applied to ground these ceramic capacitors to the PGND planes in the inner layers. Make sure these vias can sufficiently handle the inductor ripple current.
4. Place the modules evenly on the board and leave enough space between modules. If the board space is limited, try to put the modules with low power loss closely (e.g., low VOUT or IOUT) while still separating the module with high power loss.
5. If the ambient temperature is high or the board space is limited, airflow is needed to dissipate more heat from the modules. A heatsink can also be applied to the top side of the module to further improve the thermal performance.

ISL8272MEVAL2Z Schematics

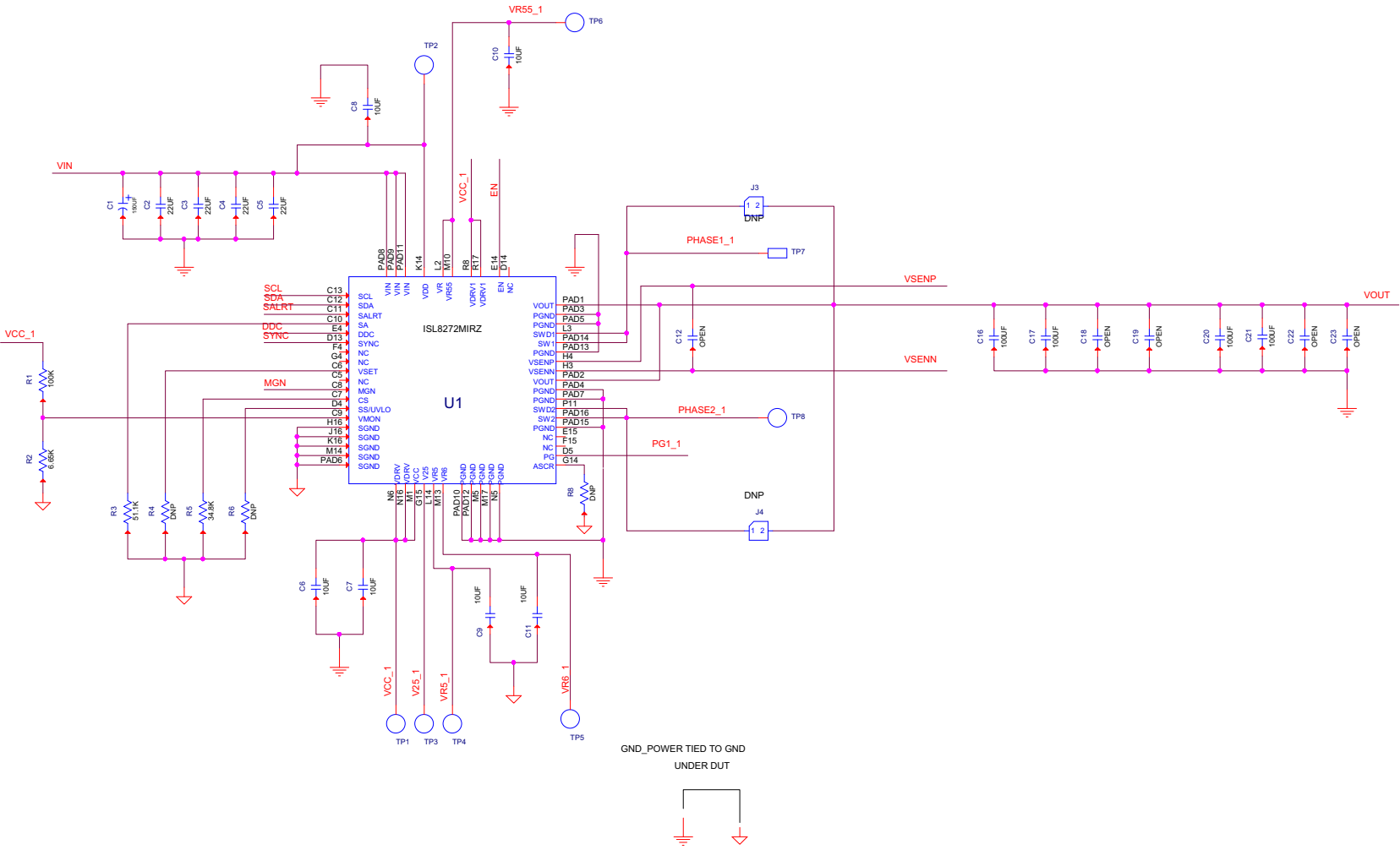

ISL8272MEVAL2Z Schematics (Continued)

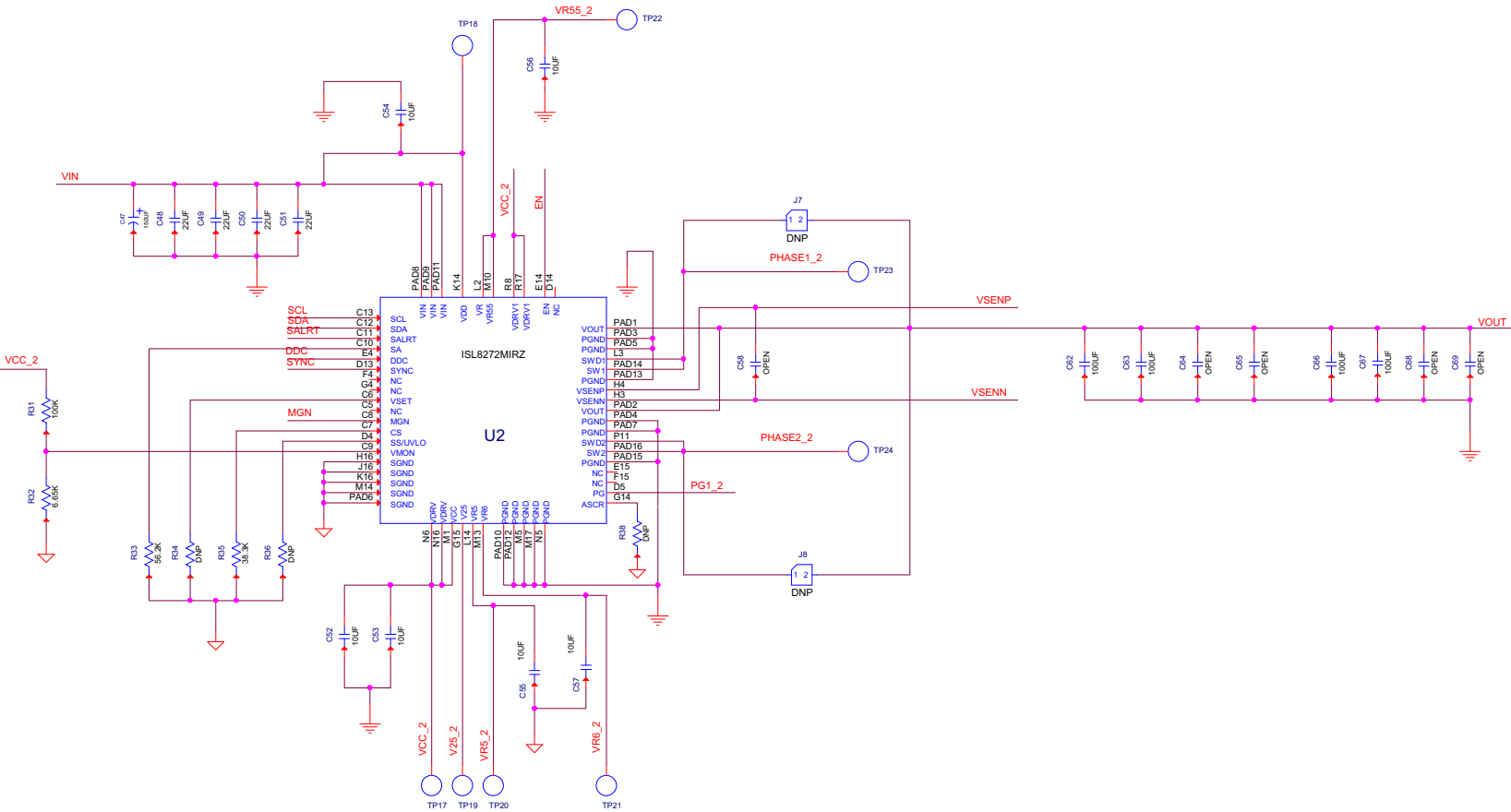

GND_POWER TIED TO GND
UNDER DUT



ISL8272MEVAL2Z Schematics (Continued)

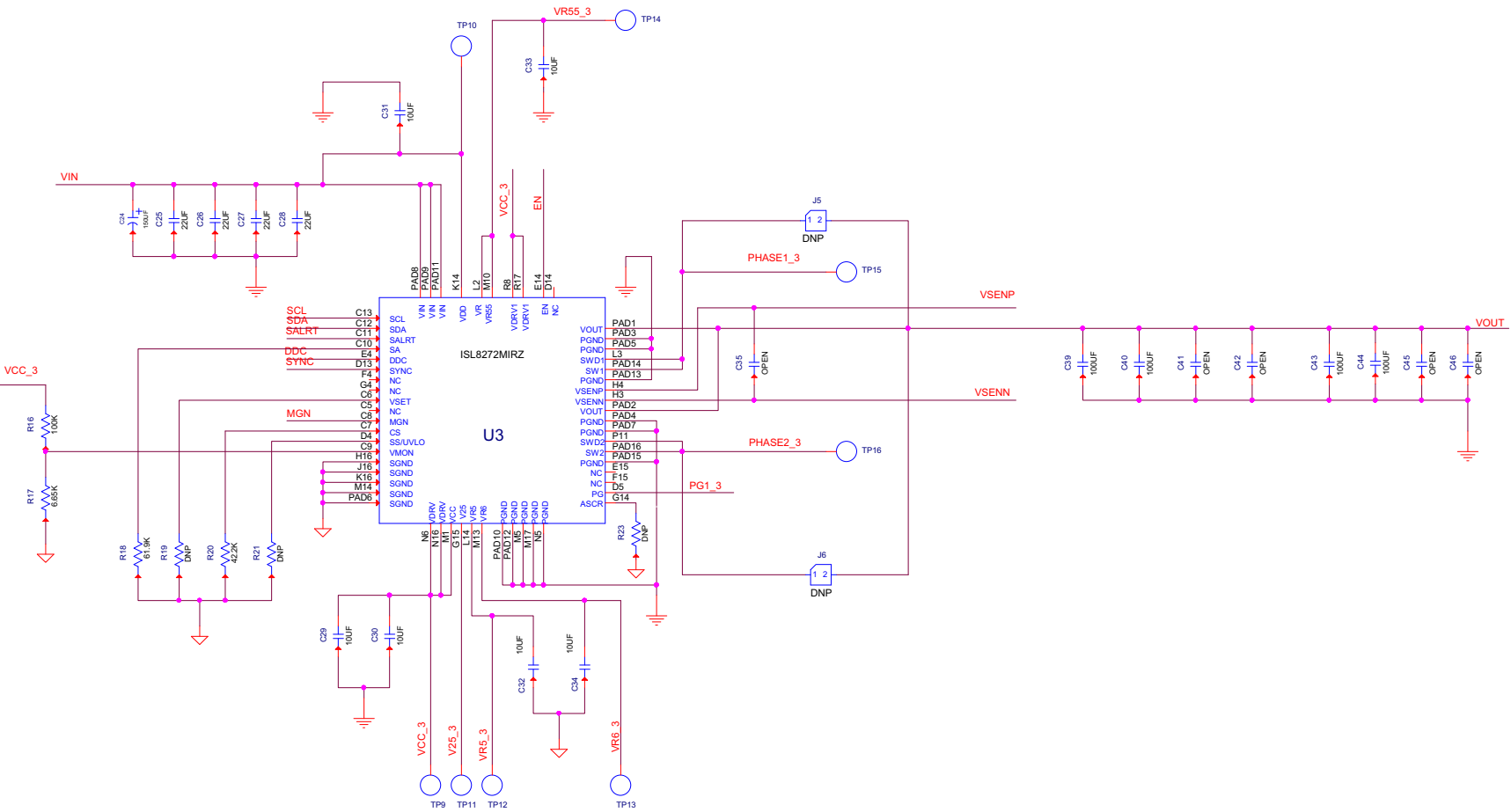

GND_POWER TIED TO GND UNDER DUT

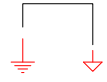

ISL8272MEVAL2Z Schematics (Continued)

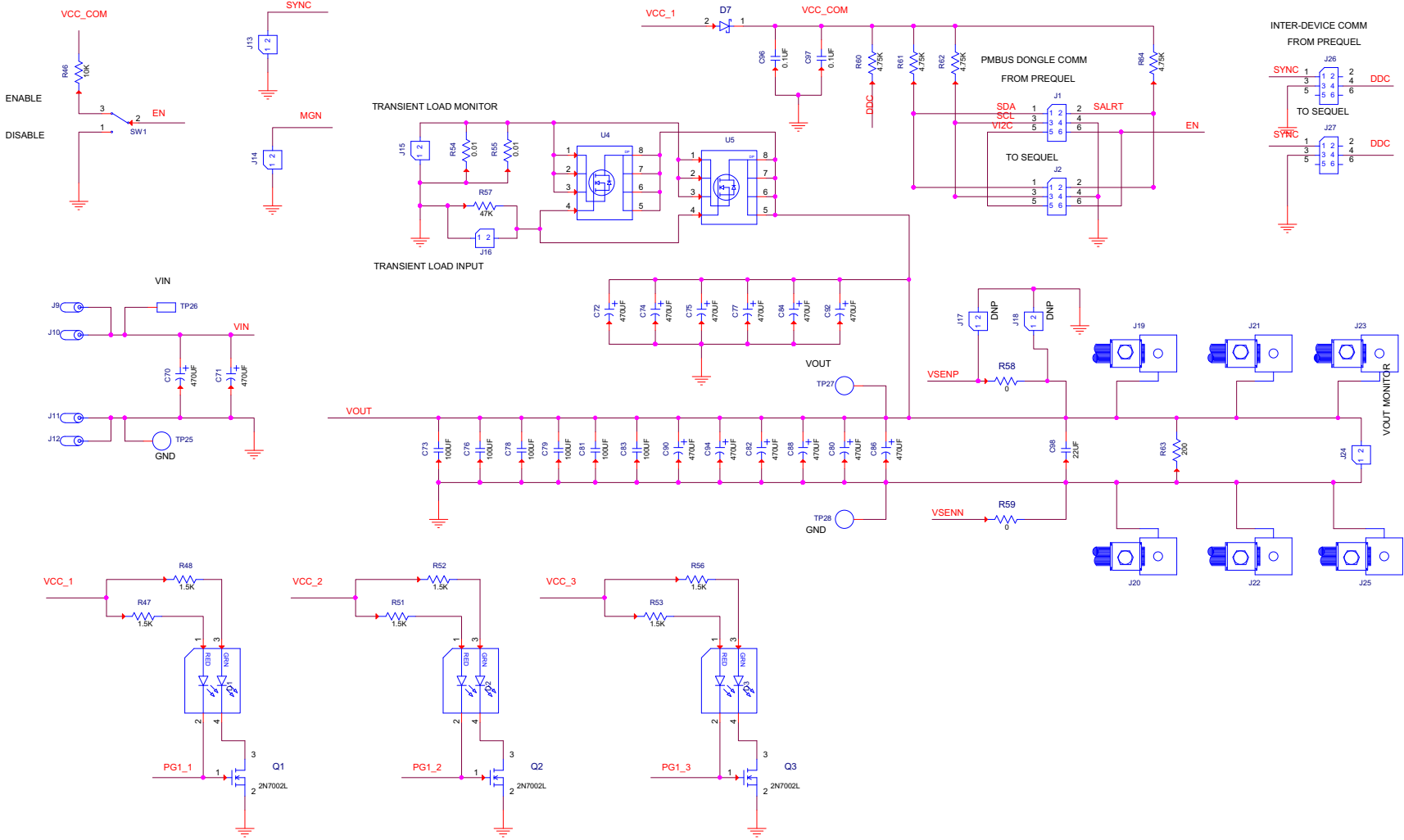

Bill of Materials

REFERENCE DESIGNATORS	QTY	MANUFACTURER	MANUFACTURER PART	DESCRIPTION
C12, C35, C58	0			CAP, SMD, 0603, DNP-PLACE HOLDER, ROHS
C96, C97	2	PANASONIC	ECJ-2VB1E104K	CAP, SMD, 0805, 0.1µF, 25V, 10%, X7R, ROHS
C98	1	TDK	C2012X5R0J226M	CAP, SMD, 0805, 22µF, 6.3V, 20%, X5R, ROHS
C6, C7, C9, C11, C29, C30, C32, C34, C52, C53, C55, C57	12	VENKEL	C1206X7R100-106KNE	CAP, SMD, 1206, 10µF, 10V, 10%, X7R, ROHS
C8, C10, C31, C33, C54, C56	6	VENKEL	C1206X7R250-106KNE	CAP, SMD, 1206, 10µF, 25V, 10%, X7R, ROHS
C16, C17, C20, C21, C39, C40, C43, C44, C62, C63, C66, C67, C73, C76, C78, C79, C81, C83	18	MURATA	GRM31CR60J107ME39L	CAP, SMD, 1206, 100µF, 6.3V, 20%, X5R, ROHS
C18, C19, C22, C23, C41, C42, C45, C46, C64, C65, C68, C69	0			CAP, SMD, 1206, DNP-PLACE HOLDER, ROHS
C2, C3, C4, C5, C25, C26, C27, C28, C48, C49, C50, C51	12	MURATA	GRM32ER71C226KE18L	CAP, SMD, 1210, 22µF, 16V, 10%, X7R, ROHS
C1, C24, C47	3	SANYO/PANASONIC	16TQC150MYF	CAP-POSCAP, SMD, 7.3x4.3, 150µF, 16V, 20%, 50mΩ, ROHS
C72, C74, C77, C90, C92, C94	6	SANYO	6TPE470MI	CAP-POSCAP, LOW ESR, SMD, D4, 470µF, 6.3V, 20%, 18mΩ, ROHS
C70, C71	2	PANASONIC	EEE-1EA471P	CAP, SMD, 10mm, 470µF, 25V, 20%, ALUM.ELEC., 380mA, ROHS
J9, J10, J11, J12	4	JOHNSON COMPONENTS	108-0740-001	CONN-JACK, BANANA-SS-SDRLESS, VERTICAL, ROHS
TP7, TP8, TP15, TP16, TP23, TP24, TP25-TP28	10	KEYSTONE	5005	CONN-COMPACT TEST PT, VERTICAL, RED, ROHS
J13, J14, J15, J16, J24	5	BERG/FCI	69190-202HLF	CONN-HEADER, 1x2, RETENTIVE, 2.54mm, 0.230 x 0.120, ROHS"
J2, J27	2	SAMTEC	SSQ-103-02-T-D-RA	CONN-SOCKET STRIP, TH, 2x3, 2.54mm, TIN, R/A, ROHS
J1, J26	2	SAMTEC	TSW-103-08-T-D-RA	CONN-HEADER, 2x3, BRKAWY, 2.54mm, TIN, R/A, ROHS
D7	1	ON SEMICONDUCTOR	BAT54XV2T1G	DIODE-SCHOTTKY, SMD, 2P, SOD523, 30V, 200mA, ROHS
D1, D2, D3	3	LUMEX	SSL-LXA3025IGC-TR	LED, SMD, 3x2.5mm, 4P, RED/GREEN, 12/20MCD, 2V
U1, U2, U3	3	INTERSIL	ISL8272MAIRZ	IC-50A DIGITAL DC/DC MODULE, 42P, HDA, ROHS
Q1, Q2, Q3	3	ON SEMICONDUCTOR	2N7002LT1G	TRANSISTOR-MOS, N-CHANNEL, SMD, SOT23, 60V, 115mA, ROHS
U4, U5	2	INFINEON TECHNOLOGY	BSC010NE2LS	TRANSIST-MOS, N-CHANNEL, 8P, PG-TDSON-8, 25V, 100A, ROHS

Bill of Materials (Continued)

REFERENCE DESIGNATORS	QTY	MANUFACTURER	MANUFACTURER PART	DESCRIPTION
R4, R6, R8, R19, R21, R23, R34, R36, R38	0			RESISTOR, SMD, 0603, 0.1%, MF, DNP-PLACE HOLDER
R46	1	PANASONIC	ERJ-2RKF1002X	RES, SMD, 0402, 10k, 1/16W, 1%, TF, ROHS
R60, R61, R62, R64	4	PANASONIC	ERJ-2RKF4751X	RES, SMD, 0402, 4.75k, 1/16W, 1%, TF, ROHS
R58, R59	2	VENKEL	CR0603-10W-000T	RES, SMD, 0603, 0Ω, 1/10W, TF, ROHS
R1, R16, R31	3	VENKEL	CR0603-10W-1003FT	RES, SMD, 0603, 100k, 1/10W, 1%, TF, ROHS
R47, R48, R51-R53, R56	6	VENKEL	CR0603-10W-1501FT	RES, SMD, 0603, 1.5k, 1/10W, 1%, TF, ROHS
R5	1	VENKEL	CR0603-10W-3482FT	RES, SMD, 0603, 34.8k, 1/10W, 1%, TF, ROHS
R35	1	PANASONIC	ERJ-3EKF3832V	RES, SMD, 0603, 38.3k, 1/10W, 1%, TF, ROHS
R20	1	ROHM	TRR03EZPF4222	RES, SMD, 0603, 42.2k, 1/10W, 1%, TF, ROHS
R57	1	YAGEO	RC0603FR-0747KL	RES, SMD, 0603, 47k, 1/10W, 1%, TF, ROHS
R3	1	VENKEL	CR0603-10W-5112FT	RES, SMD, 0603, 51.1k, 1/10W, 1%, TF, ROHS
R33	1	VENKEL	CR0603-10W-5622FT	RES, SMD, 0603, 56.2k, 1/10W, 1%, TF, ROHS
R18	1	PANASONIC	ERJ-3EKF6192V	RES, SMD, 0603, 61.9k, 1/10W, 1%, TF, ROHS
R2, R17, R32	3	YAGEO	RC0603FR-076K65L	RES, SMD, 0603, 6.65k, 1/10W, 1%, TF, ROHS
R63	1	PANASONIC	ERJ-6ENF2000V	RES, SMD, 0805, 200Ω, 1/8W, 1%, TF, ROHS
R54, R55	2	VISHAY/DALE	WSL2512R0100FEA	RES, SMD, 2512, 0.01Ω, 1W, 1%, TF, ROHS
SW1	1	C&K COMPONENTS	GT13MCBE	SWITCH-TOGGLE, THRU-HOLE, 5PIN, SPDT, 3POS, ON-OFF-ON, ROHS
J19, J20, J21, J22, J23, J25	6	BERG/FCI	KPA8CTP	HDWARE, MTG, CABLE TERMINAL, 6-14AWG, LUG&SCREW, ROHS
C75, C80, C82, C84, C86, C88	0			CAP-POSCAP, DNP-PLACE HOLDER
J3, J4, J5, J6, J7, J8, J17, J18	0			CONN-HEADER, 1x2, 2.54mm, DNP-PLACE HOLDER
TP1-TP6, TP9-TP14, TP17-TP22	0			CONN-COMPACT TEST PT, DNP-PLACE HOLDER

Configuration File Sample Configuration Files for ISL8272M Module Current Sharing. For each device, copy and paste the corresponding lines (from RESTORE_FACTORY to ### End User Store) to a notepad and save it as Confile_file_device_number.txt. The # symbol is used for a comment line. Some of the following settings are already loaded to ISL8272M module as factory defaults.

```

# Device #1
RESTORE_FACTORY                # Reset device to the factory setting
STORE_USER_ALL                 # Clears user memory space
# VOUT Related
VOUT_COMMAND                   0x2666                # 1.2 V
VOUT_MAX                       0x2a3c                # 1.32 V
VOUT_MARGIN_HIGH              0x2851                # 1.26 V
VOUT_MARGIN_LOW               0x247a                # 1.14 V
VOUT_OV_FAULT_LIMIT           0x2c28                # 1.38 V
VOUT_OV_FAULT_RESPONSE        0x80                  # Disable and no retry
VOUT_OV_WARN_LIMIT            0x2a3c                # 1.32 V
VOUT_UV_WARN_LIMIT            0x228f                # 1.08 V
VOUT_UV_FAULT_LIMIT           0x20a3                # 1.02 V
VOUT_UV_FAULT_RESPONSE        0x80                  # Disable and no retry
POWER_GOOD_ON                  0x228f                # 1.08 V
VOUT_TRANSITION_RATE           0xba00                # 1 mV/us
VOUT_DROOP                     0xb066                # 0.1 mV/A
VOUT_CAL_OFFSET                0x0000                # 0 mV/A
#Enable and Timing Related
ON_OFF_CONFIG                  0x17                  # Pin Enable, Immediate Off
FREQUENCY_SWITCH               0x0215                # 533 kHz
SYNC_CONFIG                     0x02                  # Output internal clock
# Advanced Settings
USER_CONFIG                     0x00                  # ASCR off for Start, Open Drain PG
DDC_CONFIG                     0x0605                # DDC rail ID = 6, Position 1, 6-phase
DDC_GROUP                       0x00202020           # All Broadcast enabled
# Loop Compensation
ASCR_CONFIG                     0x15a00c8            # ASCR gain = 200, Residual = 90
STORE_USER_ALL                 # Store all above settings to NVRAM
### End User Store

# Device #2
RESTORE_FACTORY                # Reset device to the factory setting
STORE_USER_ALL                 # Clears user memory space
# VOUT Related
VOUT_COMMAND                   0x2666                # 1.2 V
VOUT_MAX                       0x2a3c                # 1.32 V
VOUT_MARGIN_HIGH              0x2851                # 1.26 V
VOUT_MARGIN_LOW               0x247a                # 1.14 V
VOUT_OV_FAULT_LIMIT           0x2c28                # 1.38 V
VOUT_OV_FAULT_RESPONSE        0x80                  # Disable and no retry
VOUT_OV_WARN_LIMIT            0x2a3c                # 1.32 V
VOUT_UV_WARN_LIMIT            0x228f                # 1.08 V
VOUT_UV_FAULT_LIMIT           0x20a3                # 1.02 V
VOUT_UV_FAULT_RESPONSE        0x80                  # Disable and no retry
POWER_GOOD_ON                  0x228f                # 1.08 V
VOUT_TRANSITION_RATE           0xba00                # 1 mV/us
VOUT_DROOP                     0xb066                # 0.1 mV/A
VOUT_CAL_OFFSET                0x0000                # 0 mV/A
#Enable and Timing Related
ON_OFF_CONFIG                  0x17                  # Pin Enable, Immediate Off
FREQUENCY_SWITCH               0x0215                # 533 kHz
SYNC_CONFIG                     0x04                  # Use external clock
# Advanced Settings
USER_CONFIG                     0x00                  # ASCR off for Start, Open Drain PG
DDC_CONFIG                     0x2605                # DDC rail ID = 6, Position 2, 6-phase
DDC_GROUP                       0x00202020           # All Broadcast enabled
# Loop Compensation
ASCR_CONFIG                     0x15a00c8            # ASCR gain = 200, Residual = 90
STORE_USER_ALL                 # Store all above settings to NVRAM
### End User Store

```

Configuration File Sample Configuration Files for ISL8272M Module Current Sharing. For each device, copy and paste the corresponding lines (from RESTORE_FACTORY to ### End User Store) to a notepad and save it as Confile_file_device_number.txt. The # symbol is used for a comment line. Some of the following settings are already loaded to ISL8272M module as factory defaults. (Continued)

```

# Device #3
RESTORE_FACTORY          # Reset device to the factory setting
STORE_USER_ALL          # Clears user memory space
# VOUT Related
VOUT_COMMAND            0x2666                # 1.2 V
VOUT_MAX                0x2a3c                # 1.32 V
VOUT_MARGIN_HIGH        0x2851                # 1.26 V
VOUT_MARGIN_LOW         0x247a                # 1.14 V
VOUT_OV_FAULT_LIMIT     0x2c28                # 1.38 V
VOUT_OV_FAULT_RESPONSE 0x80                 # Disable and no retry
VOUT_OV_WARN_LIMIT      0x2a3c                # 1.32 V
VOUT_UV_WARN_LIMIT      0x228f                # 1.08 V
VOUT_UV_FAULT_LIMIT     0x20a3                # 1.02 V
VOUT_UV_FAULT_RESPONSE 0x80                 # Disable and no retry
POWER_GOOD_ON           0x228f                # 1.08 V
VOUT_TRANSITION_RATE    0xba00                # 1 mV/us
VOUT_DROOP              0xb066                # 0.1 mV/A
VOUT_CAL_OFFSET         0x0000                # 0 mV/A
#Enable and Timing Related
ON_OFF_CONFIG           0x17                 # Pin Enable, Immediate Off
FREQUENCY_SWITCH        0x0215                # 533 kHz
SYNC_CONFIG             0x04                 # Use external clock
# Advanced Settings
USER_CONFIG             0x00                 # ASCR off for Start, Open Drain PG
DDC_CONFIG              0x4605                # DDC rail ID = 6, Position 3, 6-phase
DDC_GROUP               0x00202020          # All Broadcast enabled
# Loop Compensation
ASCR_CONFIG             0x15a00c8            # ASCR gain = 200, Residual = 90
STORE_USER_ALL          # Store all above settings to NVRAM
### End User Store

```

ISL8272MEVAL2Z Evaluation Board Layout

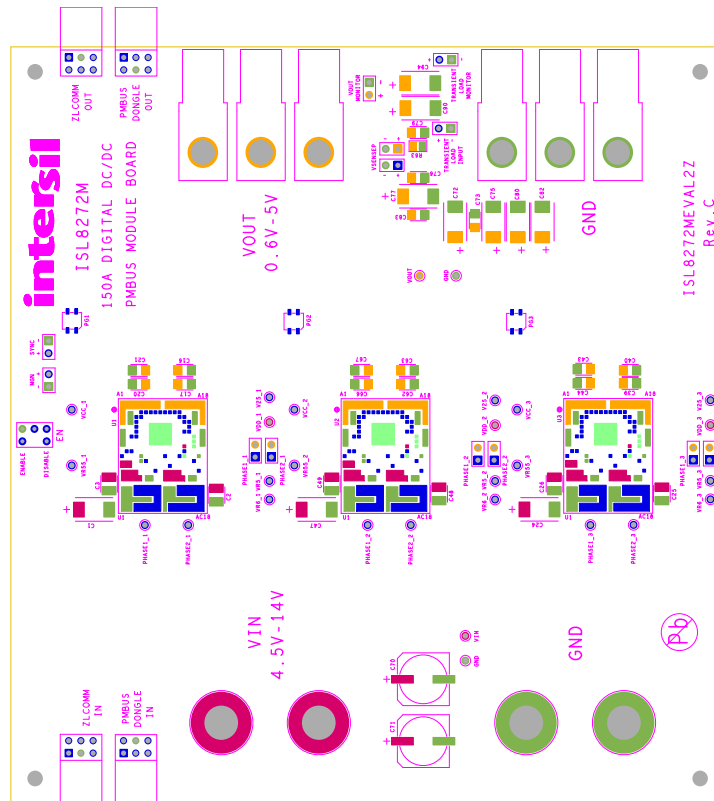

FIGURE 5. SILKSCREEN TOP

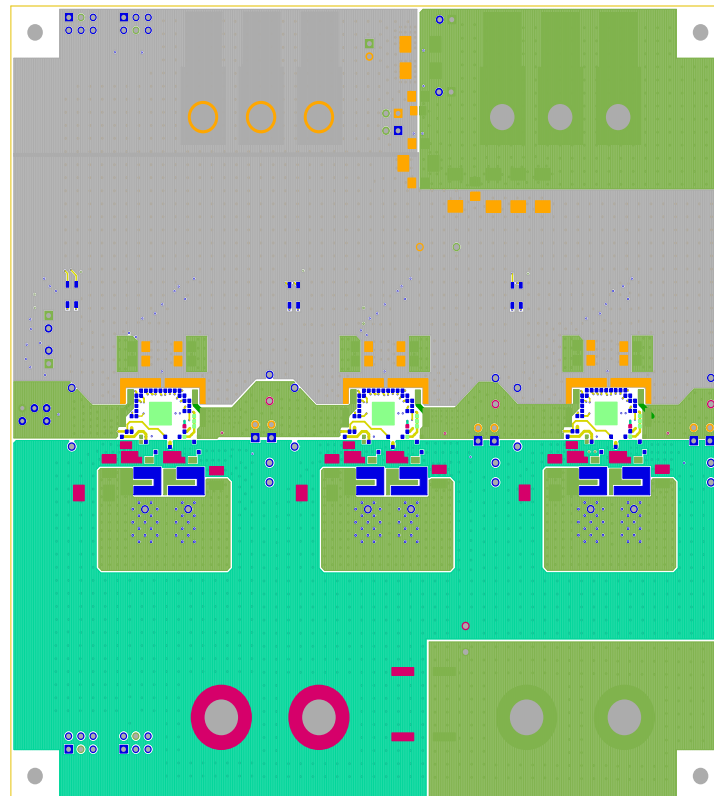

FIGURE 6. TOP LAYER COMPONENT SIDE

ISL8272MEVAL2Z Evaluation Board Layout (Continued)

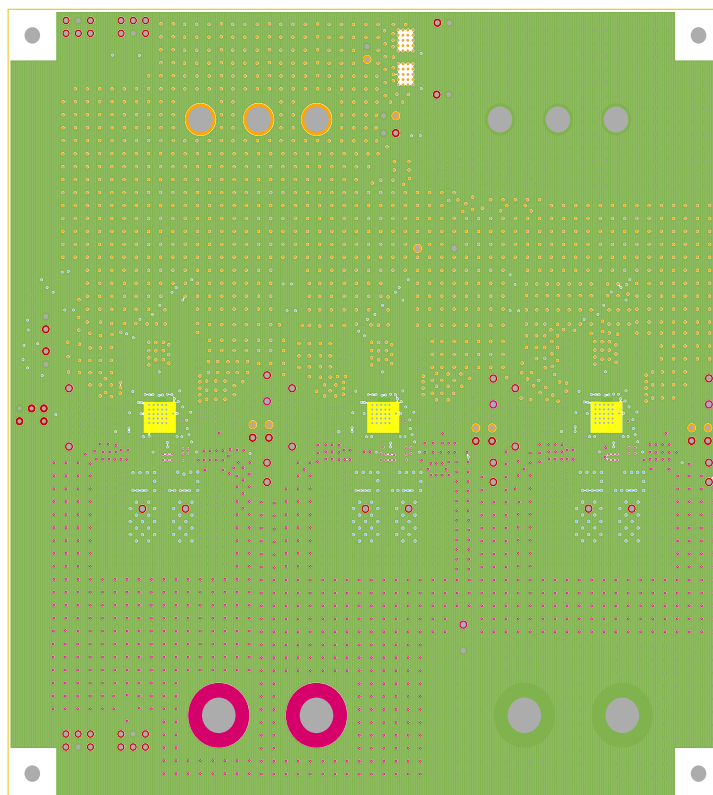

FIGURE 7. LAYER 2

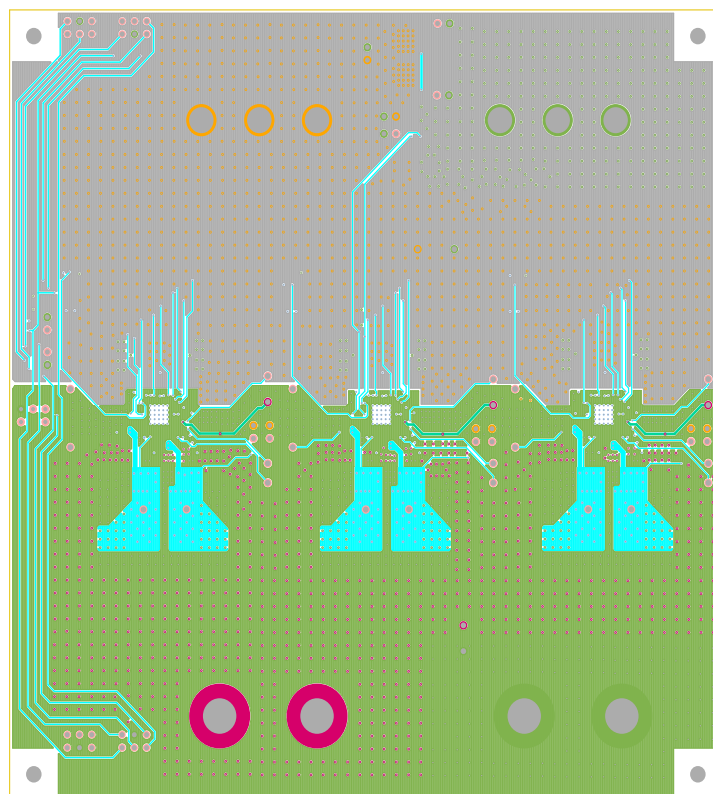

FIGURE 8. LAYER 3

ISL8272MEVAL2Z Evaluation Board Layout (Continued)

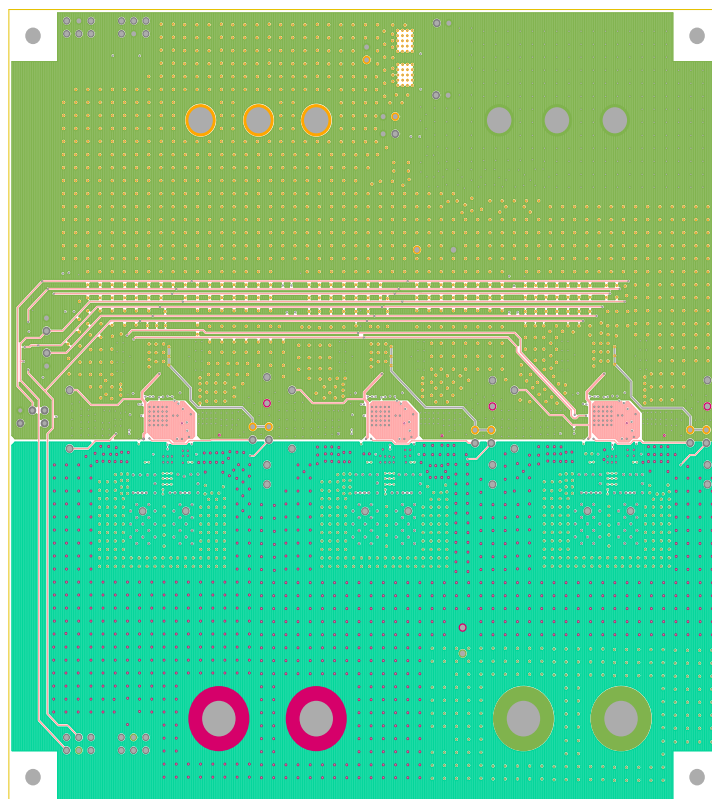

FIGURE 9. LAYER 4

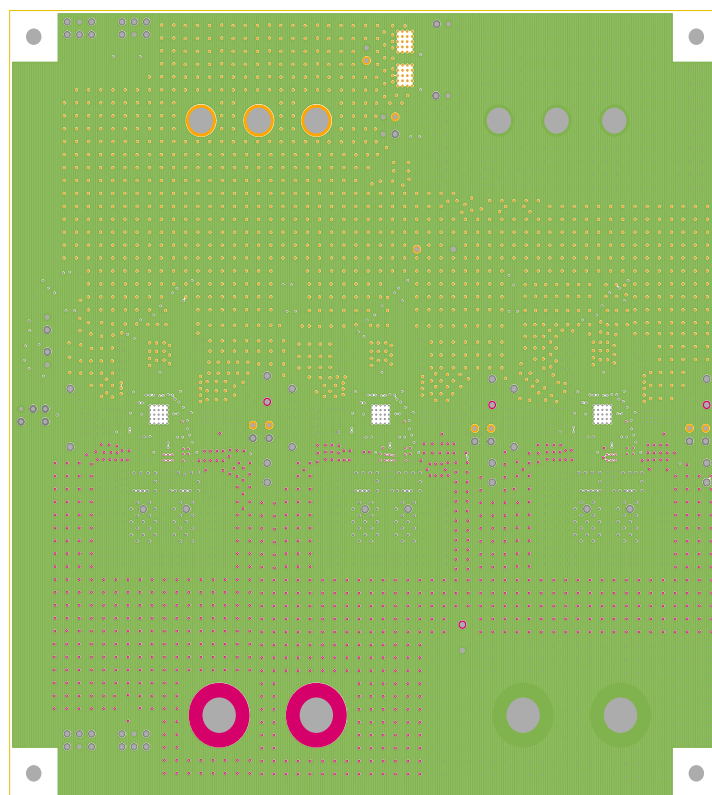

FIGURE 10. LAYER 5

ISL8272MEVAL2Z Evaluation Board Layout (Continued)

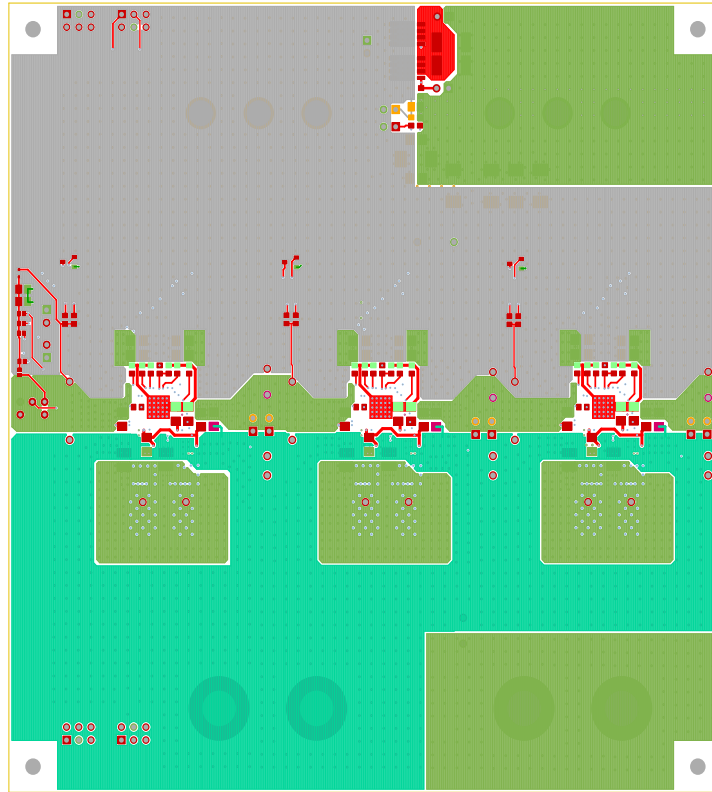

FIGURE 11. BOTTOM LAYER SOLDER SIDE

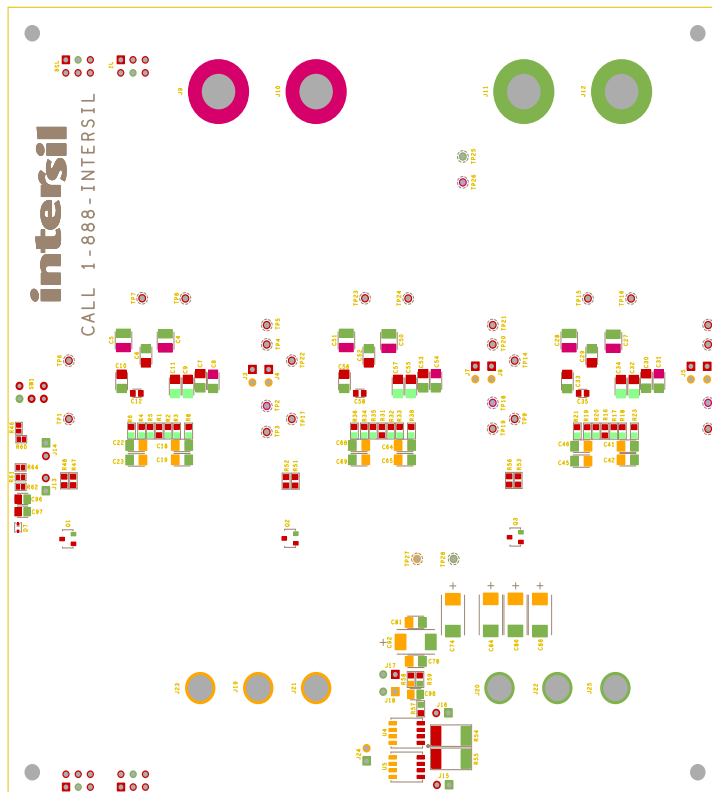

FIGURE 12. SILKSCREEN BOTTOM

Measured Data

The following data was acquired using a ISL8272MEVAL2Z evaluation board.

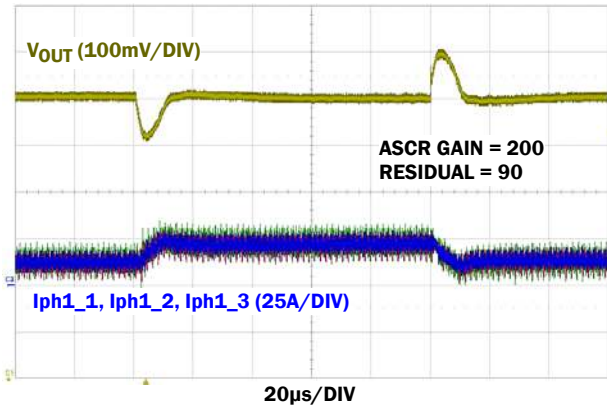

FIGURE 13. LOAD TRANSIENT RESPONSE AT $V_{IN} = 12V$, $V_{OUT} = 1V$, $I_{OUT} = 50A$ TO $125A$ ($>100A/\mu s$), V_{OUT} DROOP = $0.1mV/A$, $f_{SW} = 533kHz$, $C_{OUT} = 18 \times 100\mu F$ CERAMIC + $6 \times 470\mu F$ POSCAP

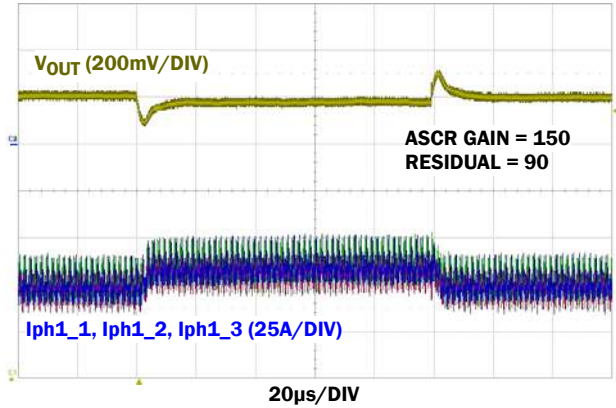

FIGURE 14. LOAD TRANSIENT RESPONSE AT $V_{IN} = 12V$, $V_{OUT} = 3.3V$, $I_{OUT} = 30A$ TO $105A$ ($>100A/\mu s$), V_{OUT} DROOP = $0.2mV/A$, $f_{SW} = 533kHz$, $C_{OUT} = 18 \times 100\mu F$ CERAMIC + $6 \times 470\mu F$ POSCAP

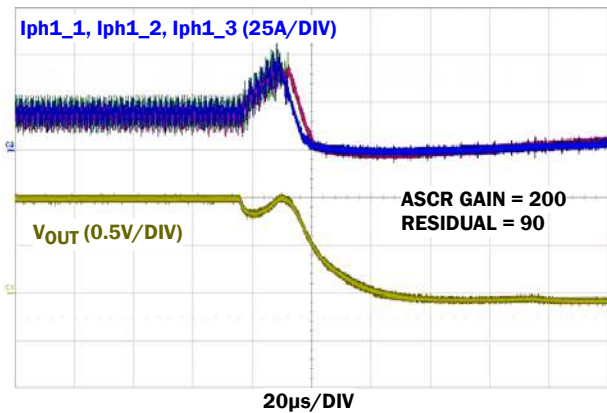

FIGURE 15. OUTPUT SHORT CIRCUIT PROTECTION AT $V_{IN} = 12V$, $V_{OUT} = 1V$, $f_{SW} = 533kHz$

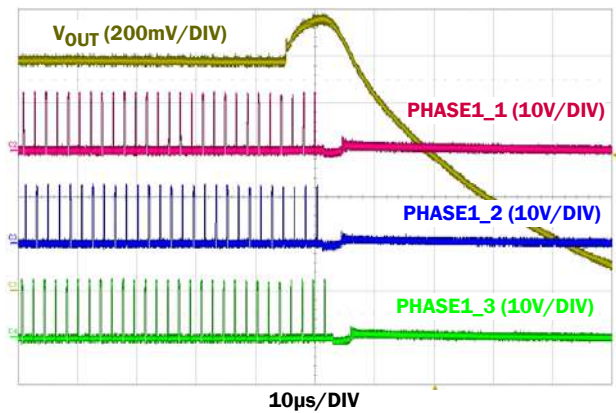

FIGURE 16. OUTPUT OVERVOLTAGE PROTECTION AT $V_{IN} = 12V$, $V_{OUT} = 1V$, $f_{SW} = 533kHz$, $V_{OUT_OV_FAULT_LIMIT} = 1.15V$

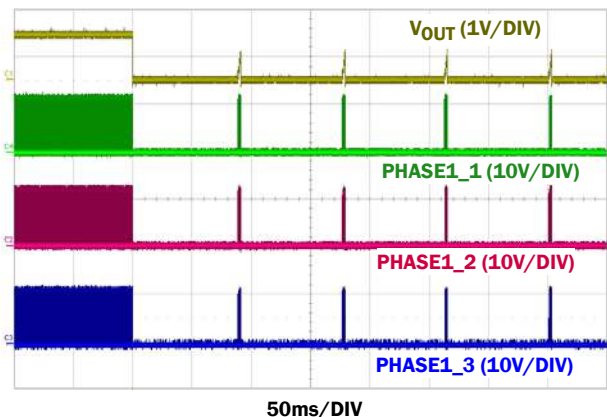

FIGURE 17. OUTPUT SHORT CIRCUIT PROTECTION WITH CONTINUOUS RETRY ENABLED (HICCUP MODE), $V_{IN} = 12V$, $V_{OUT} = 1V$

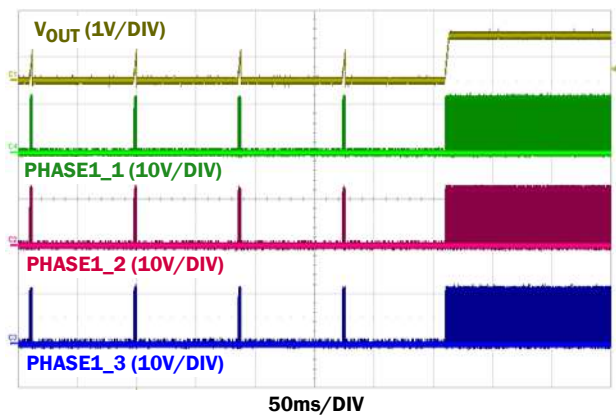

FIGURE 18. OUTPUT SHORT CIRCUIT RECOVERY FROM CONTINUOUS RETRY (HICCUP MODE), $V_{IN} = 12V$, $V_{OUT} = 1V$

Measured Data The following data was acquired using a ISL8272MEVAL2Z evaluation board. (Continued)

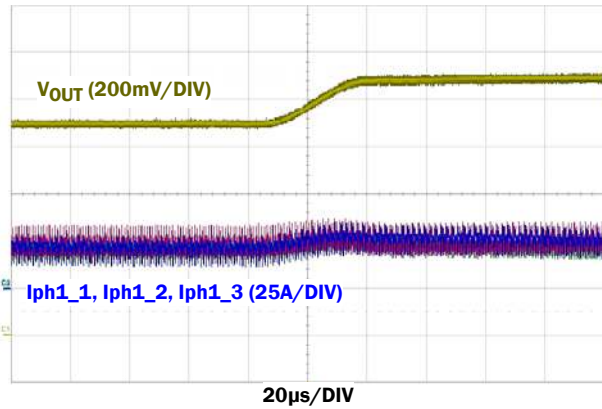

FIGURE 19. DYNAMIC VOLTAGE SCALING WITH VOUT CHANGE FROM 0.9V TO 1.1V, $V_{IN} = 12V$, $V_{OUT_TRANSITION_RATE} = 1mV/\mu s$

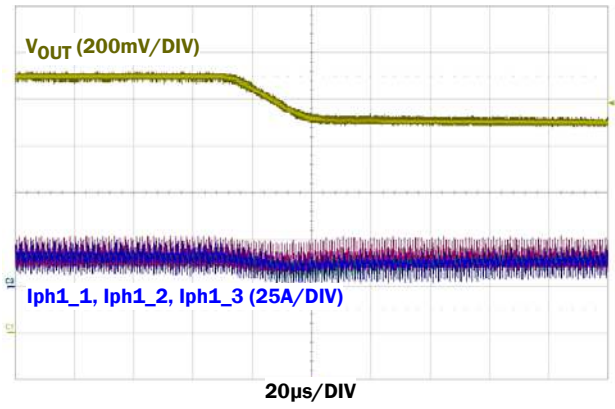

FIGURE 20. DYNAMIC VOLTAGE SCALING WITH VOUT CHANGE FROM 1.1V TO 0.9V, $V_{IN} = 12V$, $V_{OUT_TRANSITION_RATE} = 1mV/\mu s$



FIGURE 21. STATIC CURRENT SHARING MONITORED FROM THE POWERNAVIGATOR SOFTWARE, $V_{IN} = 12V$, $V_{OUT} = 1V$, $I_{OUT} = 150A$, $f_{SW} = 421kHz$

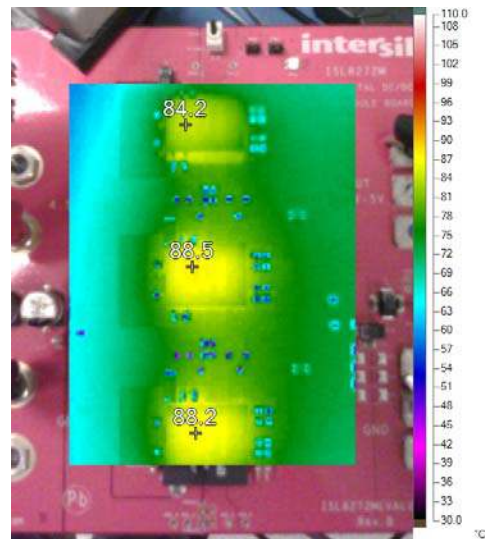

FIGURE 22. THERMAL IMAGE AT $V_{IN} = 12V$, $V_{OUT} = 1V$, $I_{OUT} = 150A$, $f_{SW} = 421kHz$, $T_A = +25^\circ C$, NO AIRFLOW

Notice

1. Descriptions of circuits, software and other related information in this document are provided only to illustrate the operation of semiconductor products and application examples. You are fully responsible for the incorporation or any other use of the circuits, software, and information in the design of your product or system. Renesas Electronics disclaims any and all liability for any losses and damages incurred by you or third parties arising from the use of these circuits, software, or information.
2. Renesas Electronics hereby expressly disclaims any warranties against and liability for infringement or any other claims involving patents, copyrights, or other intellectual property rights of third parties, by or arising from the use of Renesas Electronics products or technical information described in this document, including but not limited to, the product data, drawings, charts, programs, algorithms, and application examples.
3. No license, express, implied or otherwise, is granted hereby under any patents, copyrights or other intellectual property rights of Renesas Electronics or others.
4. You shall not alter, modify, copy, or reverse engineer any Renesas Electronics product, whether in whole or in part. Renesas Electronics disclaims any and all liability for any losses or damages incurred by you or third parties arising from such alteration, modification, copying or reverse engineering.
5. Renesas Electronics products are classified according to the following two quality grades: "Standard" and "High Quality". The intended applications for each Renesas Electronics product depends on the product's quality grade, as indicated below.
"Standard": Computers; office equipment; communications equipment; test and measurement equipment; audio and visual equipment; home electronic appliances; machine tools; personal electronic equipment; industrial robots; etc.
"High Quality": Transportation equipment (automobiles, trains, ships, etc.); traffic control (traffic lights); large-scale communication equipment; key financial terminal systems; safety control equipment; etc.
Unless expressly designated as a high reliability product or a product for harsh environments in a Renesas Electronics data sheet or other Renesas Electronics document, Renesas Electronics products are not intended or authorized for use in products or systems that may pose a direct threat to human life or bodily injury (artificial life support devices or systems; surgical implantations; etc.), or may cause serious property damage (space system; undersea repeaters; nuclear power control systems; aircraft control systems; key plant systems; military equipment; etc.). Renesas Electronics disclaims any and all liability for any damages or losses incurred by you or any third parties arising from the use of any Renesas Electronics product that is inconsistent with any Renesas Electronics data sheet, user's manual or other Renesas Electronics document.
6. When using Renesas Electronics products, refer to the latest product information (data sheets, user's manuals, application notes, "General Notes for Handling and Using Semiconductor Devices" in the reliability handbook, etc.), and ensure that usage conditions are within the ranges specified by Renesas Electronics with respect to maximum ratings, operating power supply voltage range, heat dissipation characteristics, installation, etc. Renesas Electronics disclaims any and all liability for any malfunctions, failure or accident arising out of the use of Renesas Electronics products outside of such specified ranges.
7. Although Renesas Electronics endeavors to improve the quality and reliability of Renesas Electronics products, semiconductor products have specific characteristics, such as the occurrence of failure at a certain rate and malfunctions under certain use conditions. Unless designated as a high reliability product or a product for harsh environments in a Renesas Electronics data sheet or other Renesas Electronics document, Renesas Electronics products are not subject to radiation resistance design. You are responsible for implementing safety measures to guard against the possibility of bodily injury, injury or damage caused by fire, and/or danger to the public in the event of a failure or malfunction of Renesas Electronics products, such as safety design for hardware and software, including but not limited to redundancy, fire control and malfunction prevention, appropriate treatment for aging degradation or any other appropriate measures. Because the evaluation of microcomputer software alone is very difficult and impractical, you are responsible for evaluating the safety of the final products or systems manufactured by you.
8. Please contact a Renesas Electronics sales office for details as to environmental matters such as the environmental compatibility of each Renesas Electronics product. You are responsible for carefully and sufficiently investigating applicable laws and regulations that regulate the inclusion or use of controlled substances, including without limitation, the EU RoHS Directive, and using Renesas Electronics products in compliance with all these applicable laws and regulations. Renesas Electronics disclaims any and all liability for damages or losses occurring as a result of your noncompliance with applicable laws and regulations.
9. Renesas Electronics products and technologies shall not be used for or incorporated into any products or systems whose manufacture, use, or sale is prohibited under any applicable domestic or foreign laws or regulations. You shall comply with any applicable export control laws and regulations promulgated and administered by the governments of any countries asserting jurisdiction over the parties or transactions.
10. It is the responsibility of the buyer or distributor of Renesas Electronics products, or any other party who distributes, disposes of, or otherwise sells or transfers the product to a third party, to notify such third party in advance of the contents and conditions set forth in this document.
11. This document shall not be reprinted, reproduced or duplicated in any form, in whole or in part, without prior written consent of Renesas Electronics.
12. Please contact a Renesas Electronics sales office if you have any questions regarding the information contained in this document or Renesas Electronics products.
(Note 1) "Renesas Electronics" as used in this document means Renesas Electronics Corporation and also includes its directly or indirectly controlled subsidiaries.
(Note 2) "Renesas Electronics product(s)" means any product developed or manufactured by or for Renesas Electronics.

(Rev.4.0-1 November 2017)



SALES OFFICES

Renesas Electronics Corporation

<http://www.renesas.com>

Refer to "<http://www.renesas.com/>" for the latest and detailed information.

Renesas Electronics America Inc.
1001 Murphy Ranch Road, Milpitas, CA 95035, U.S.A.
Tel: +1-408-432-8888, Fax: +1-408-434-5351

Renesas Electronics Canada Limited
9251 Yonge Street, Suite 8309 Richmond Hill, Ontario Canada L4C 9T3
Tel: +1-905-237-2004

Renesas Electronics Europe Limited
Dukes Meadow, Millboard Road, Bourne End, Buckinghamshire, SL8 5FH, U.K
Tel: +44-1628-651-700, Fax: +44-1628-651-804

Renesas Electronics Europe GmbH
Arcadiastrasse 10, 40472 Düsseldorf, Germany
Tel: +49-211-6503-0, Fax: +49-211-6503-1327

Renesas Electronics (China) Co., Ltd.
Room 1709 Quantum Plaza, No.27 ZhichunLu, Haidian District, Beijing, 100191 P. R. China
Tel: +86-10-8235-1155, Fax: +86-10-8235-7679

Renesas Electronics (Shanghai) Co., Ltd.
Unit 301, Tower A, Central Towers, 555 Langao Road, Putuo District, Shanghai, 200333 P. R. China
Tel: +86-21-2226-0888, Fax: +86-21-2226-0999

Renesas Electronics Hong Kong Limited
Unit 1601-1611, 16/F., Tower 2, Grand Century Place, 193 Prince Edward Road West, Mongkok, Kowloon, Hong Kong
Tel: +852-2265-6688, Fax: +852-2886-9022

Renesas Electronics Taiwan Co., Ltd.
13F, No. 363, Fu Shing North Road, Taipei 10543, Taiwan
Tel: +886-2-8175-9600, Fax: +886-2-8175-9670

Renesas Electronics Singapore Pte. Ltd.
80 Bendemeer Road, Unit #06-02 Hyflux Innovation Centre, Singapore 339949
Tel: +65-6213-0200, Fax: +65-6213-0300

Renesas Electronics Malaysia Sdn.Bhd.
Unit 1207, Block B, Menara Amcorp, Amcorp Trade Centre, No. 18, Jln Persiaran Barat, 46050 Petaling Jaya, Selangor Darul Ehsan, Malaysia
Tel: +60-3-7955-9390, Fax: +60-3-7955-9510

Renesas Electronics India Pvt. Ltd.
No.777C, 100 Feet Road, HAL 2nd Stage, Indiranagar, Bangalore 560 038, India
Tel: +91-80-67208700, Fax: +91-80-67208777

Renesas Electronics Korea Co., Ltd.
17F, KAMCO Yangjae Tower, 262, Gangnam-daero, Gangnam-gu, Seoul, 06265 Korea
Tel: +82-2-558-3737, Fax: +82-2-558-5338