

THIS DRAWING IS UNPUBLISHED. RELEASED FOR PUBLICATION
© COPYRIGHT BY TYCO ELECTRONICS CORPORATION. ALL RIGHTS RESERVED.

REVISIONS				
P	LTR	DESCRIPTION	DATE	APVD
E		REVISED(ECR-13-000208)	08. JAN. '13	JM HG
E1		REVISED(ECR-13-008839)	01. JUN. '13	JM HG
E2		REVISED(ECR-14-014192)	29. SEP. '14	JM HG
E3		REVISED(ECR-16-008211)	08. JUN. '16	JM JW
F		REVISED(ECR-20-012240)	31. AUG. '20	YH YJ

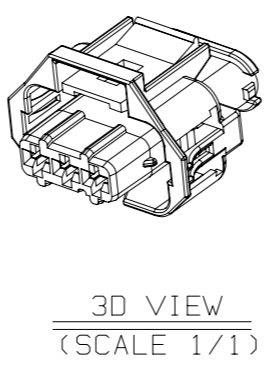

ACCESSORIES DRAWING
 ① DBL HSG : P/N:936106
 SCALE : 2/1

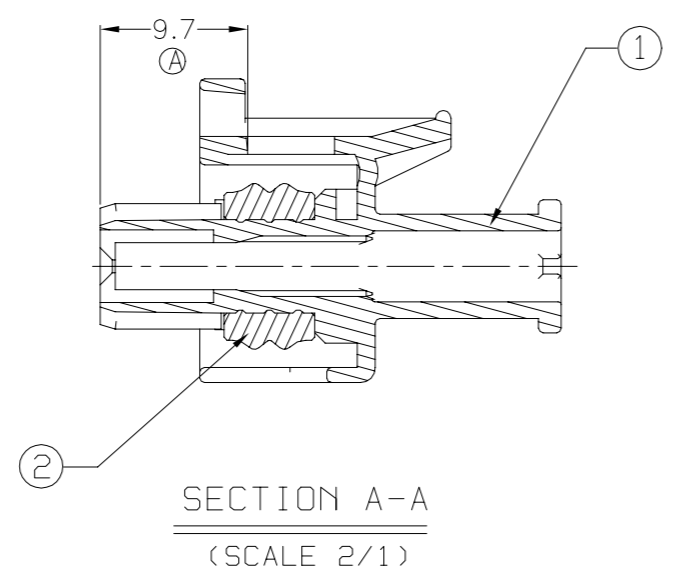
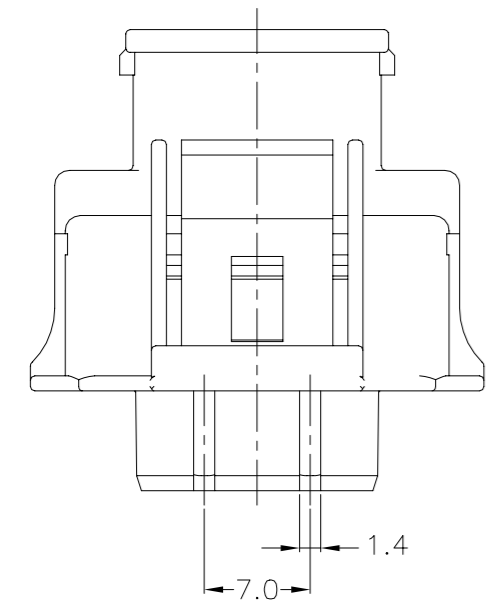
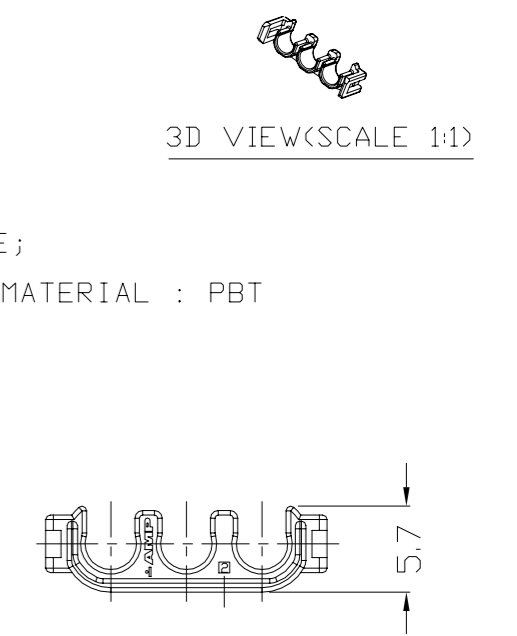
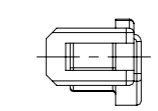
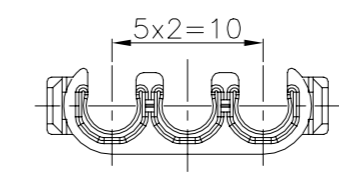
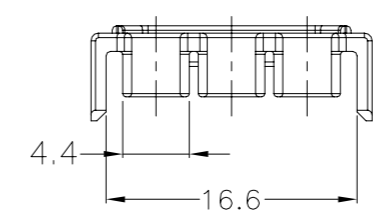

NOTE;
 ① MATERIAL : PBT

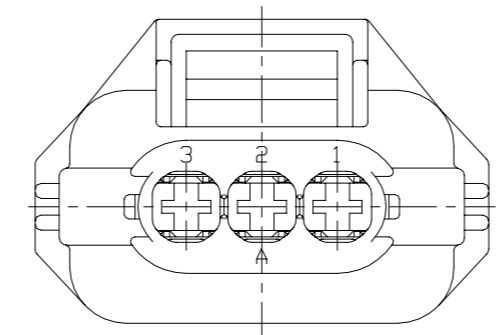
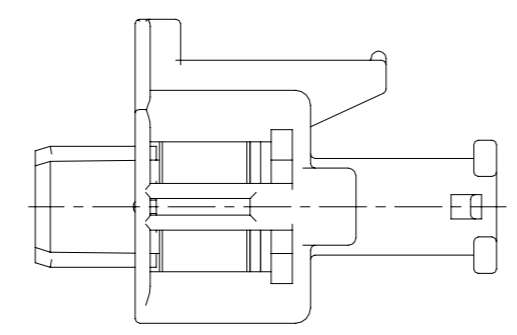
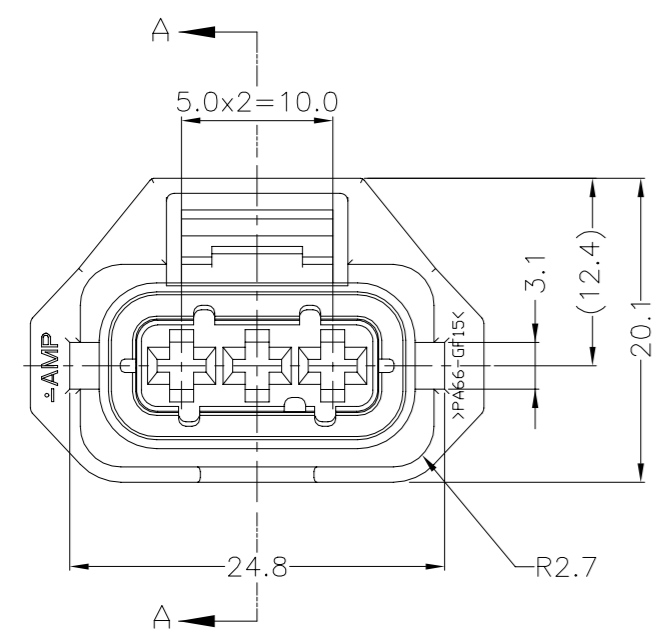

② COVER HSG : P/N:936112
 SCALE : 2/1

NOTE;
 ① MATERIAL : NYLON 66
 ② CORRUGATOR DIAMETER : ϕ 7.0

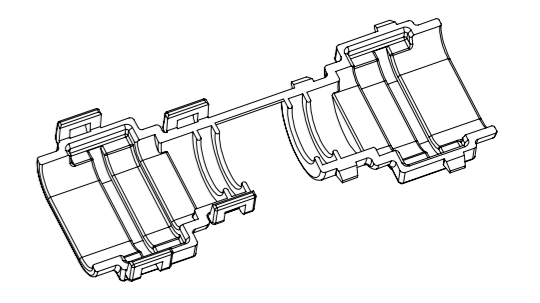

3D VIEW (SCALE 1:1)

4. APPLIED RECEPTACLE CONTACT P/N:

DESCRIPTION	2.8mm SENSOR-FLAT RECEPTACLE	
Part NO.	967542	967543
WIRE SIZE(mm ²)	0.5 ~ 1.0	1.25 ~ 2.5

5. APPLIED WIRE SEAL P/N:

DESCRIPTION	SINGLE-WIRE SEAL(5mm Hole)	
Part NO.	828904	828905
INSULATION DIA.(ϕ)	1.2 ~ 2.1mm	2.2 ~ 3.0mm

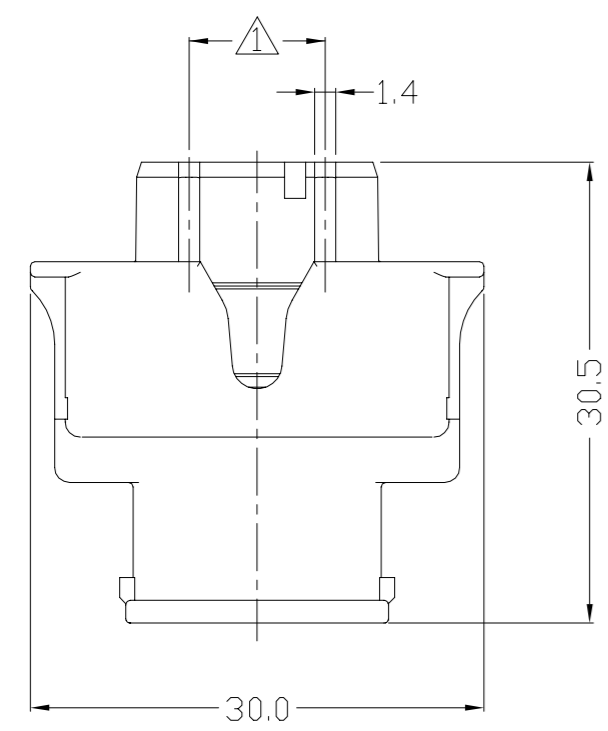
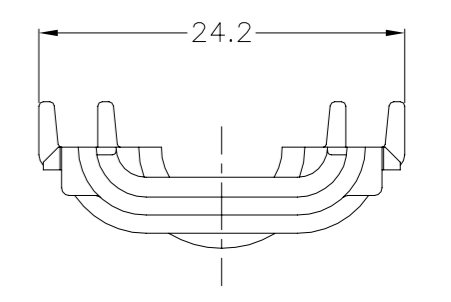
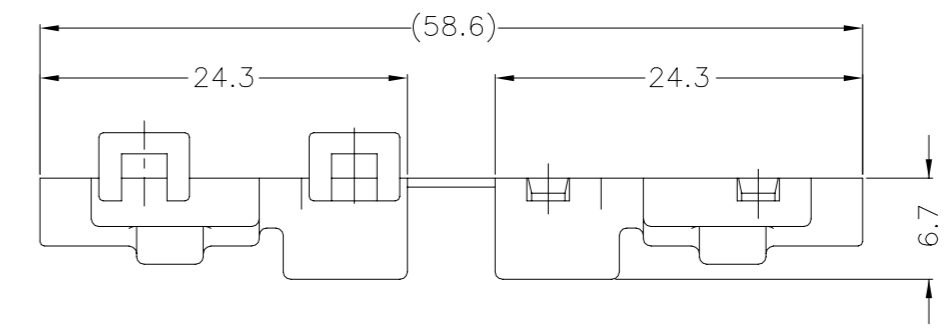

(TABLE 1)

CODE I : 936060-1, -2, -3 1-936060-3	CODE II : N/A
	SEE DRAWING 936061
CODE III : 2-936060-1, -3	CODE IV : TBD

NOTE;
 ① CODING IS AS FOLLOWS; SEE TABLE 1.
 2. 0.15 MAX. WARPAGE AND 0.2 MAX. FLASH ARE PERMISSIBLE
 3. SURFACE DEFECTS ARE NOT ACCEPTABLE AS FOLLOWS: SINK, WELD LINES, HAIRCRACKS, STAINS & SCORES

①	②	③	④	⑤	⑥	⑦	⑧	⑨	⑩			
1	1					936801-5	INNER SEAL	SILICONE	YELLOW	2		
		1	1			936801-3	INNER SEAL	SILICONE	BLUE	2		
				1	1	936801-1	INNER SEAL	SILICONE	RED ORANGE	2		
					1	2-936105-3	PLUG HSG	PA 66 GF15	GRAY	1		
					1	2-936105-1	PLUG HSG	PA 66 GF15	BLACK	1		
				1	1	936105-3	PLUG HSG	PA 66 GF15	GRAY	1		
				1	1	936105-1	PLUG HSG	PA 66 GF15	BLACK	1		
Q'TY					P/N		DESCRIPTION		MATERIAL		COLOR	NO

ASSEMBLY P/N 2-936060-3 2-936060-1 1-936060-3 936060-2 936060-3 936060-1	DIMENSIONS: MM		TOLERANCES UNLESS OTHERWISE SPECIFIED: 0 <XX<10 ± 0.2 10<XX<30 ± 0.25 30<XX ± 0.3 ANGLES ± 3°		DWN JM JEON		TE Connectivity		
	3rd ANGLE PROJECTION		FINISH		CHK -				
	MATERIAL		SEE TABLE		APVD JW JUNG		NAME		
	CUSTOMER DRAWING		SCALE 2/1		PRODUCT SPEC		2.8mm SEALED 3P PLUG ASSEMBLY (FLAT SENSOR CONNECTOR)		
				APPLICATION SPEC		DRAWING NO		RESTRICTED TO	
				WEIGHT		114-18144		SIZE CAGE CODE	
				SCALE 2/1		A200779		DRAWING NO	
				SHEET 1 OF 1		936060		REV F	