

REVISIONS					
P	LTR	DESCRIPTION	DATE	DWN	APVD
A		REVISED PER ECN-21-101691	26MAR2021	ED	WH

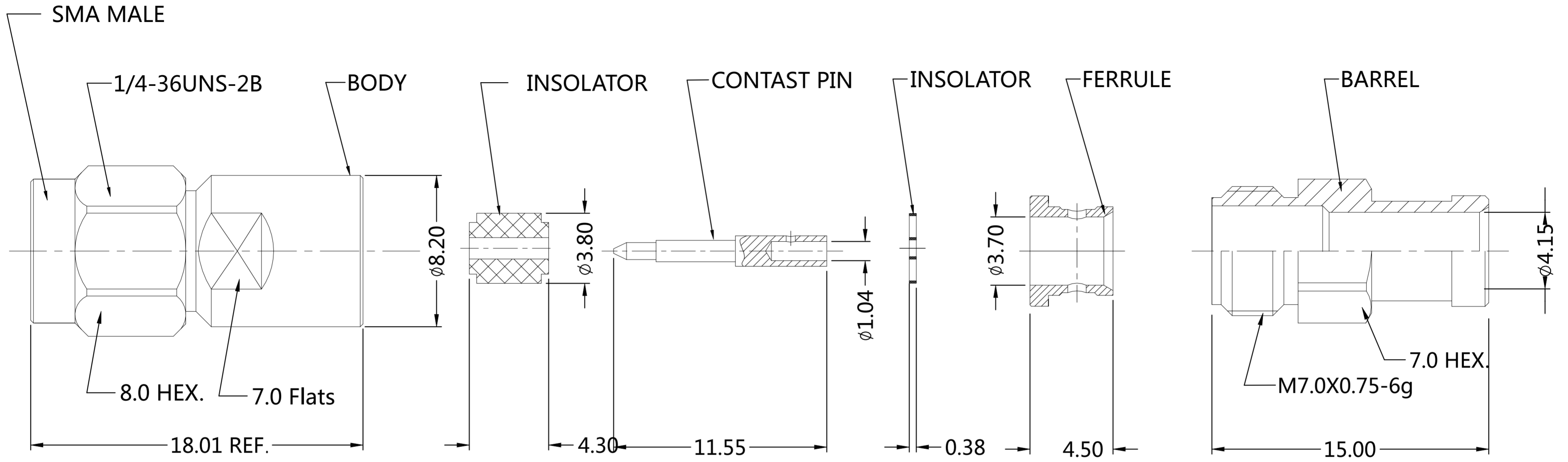

NOTES:

- 1 PACK IN ACCORDANCE WITH TE SPEC 107-3275
- 2 ALL DIMENSIONS ARE NOMINAL FOR REFERENCE ONLY UNLESS OTHERWISE STATED
- 3 GOLD PLATING 0.254um MIN OVER NIKEL PLATING 1.27um MIN OVER COPPER PLATING 1.27um MIN
- 4 GOLD PLATING 0.762um MIN OVER NIKEL PLATING 1.27um MIN OVER COPPER PLATING 1.27um MIN

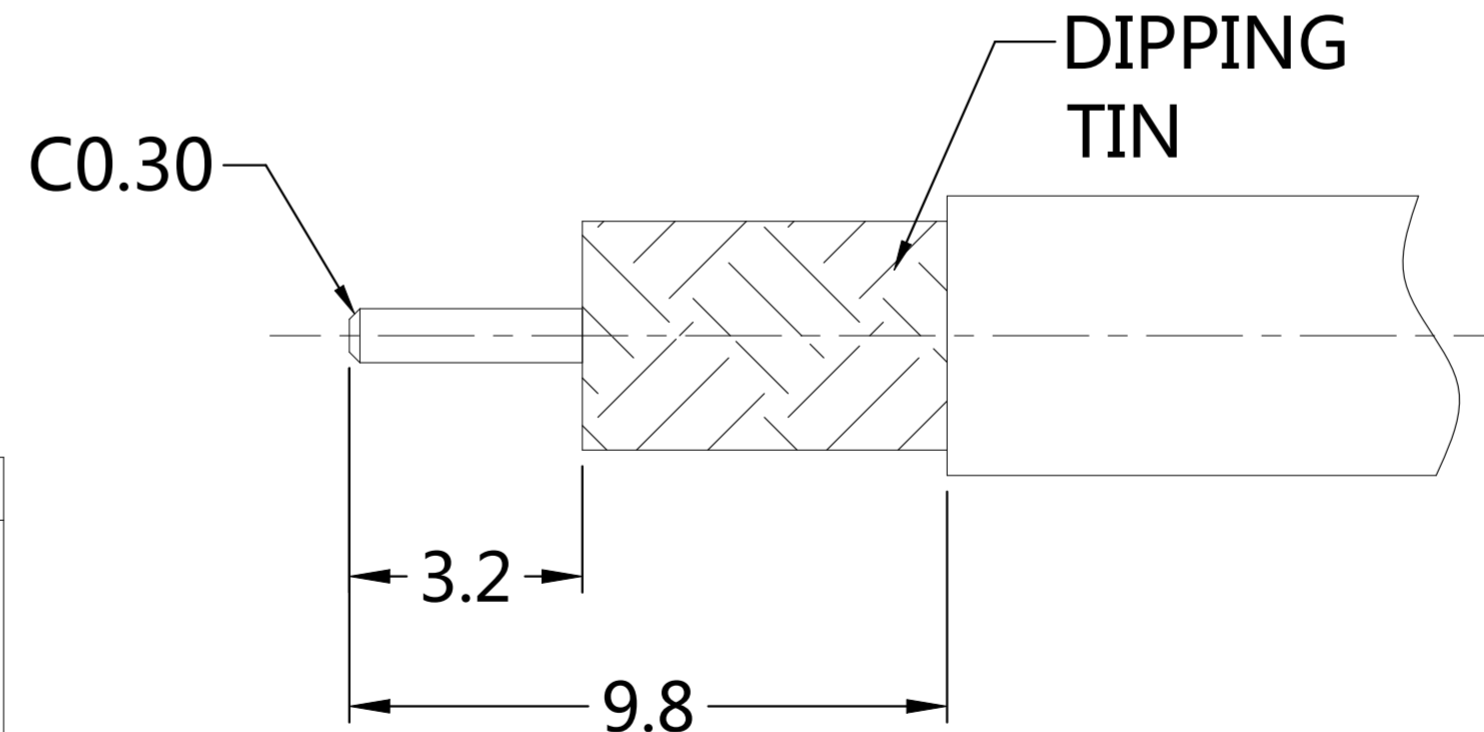

RECOMMENDED CABLE STRIPPING DIM'S

ELECTRICAL	MECHANICAL	ENVIRONMENTAL
Impedance (Ohm) _____50	Interface Dimension MIL-STD-348B Fig. _____310-2	TEMPERATURE RANGE _____ -65°C TO + 165°C
Frequency Range (GHz) _____DC to 27GHz	Recommended Coupling Torque _____7 to 10 In-Lbs	THERMAL SHOCK _____MIL-STD-202, METH.107, COND.B
Voltage Rating (Peak) _____@ Sea Level 335 V RMS	Force to Engage and Disengage (In/lbs) _____2.0 MAX	CORROSION _____MIL-STD-202, METH.101, COND.B
Insulation Resistance (MIN.) _____5000 M ohms	Center Contact Captivation Axial (Lbs) _____6.0 Radial (In/Oz) _____N/A	VIBRATION _____MIL-STD-202, METH.204, COND.D
Contact Resistance (Milliohms MAX) Center Contact _____3.0 Outer Contact _____2.0	Cable Retention Axial (Lbs) _____N/A	SHOCK _____MIL-STD-202, METH.213, COND.I
Dielectric Withstand Voltage: _____750 V RMS Max	Mating cycles _____500 cycles	MOISTURE RESISTANCE _____MIL-STD-202, METH.106.
Insertion Loss : _____0.1*SQRT(F) dB		ROHS _____COMPLIANT
VSWR: _____1.3 MAX(DC-27GHz)		
RF leakage: _____N/A		
3rd Intermodulation: _____N/A		

QTY	DESCRIPTION	MATERIAL	PLATING	FINISH	ITEM
5	PASSIVATION	STAINLESS STEEL			BARREL
4	3	BRASS			FERRULE
3	/	PTFE			INSULATOR
2	4	BeCu			CENTER CONTACT
1	PASSIVATION	STAINLESS STEEL			BODY
1	2081886-1	PLATING			DESCRIPTION

THIS DRAWING IS A CONTROLLED DOCUMENT.		DWN ED	29DEC2020	PER ASSY	PARTS LIST	
DIMENSIONS: mm		CHK RZ	29DEC2020	TE Connectivity		
TOLERANCES UNLESS OTHERWISE SPECIFIED: 0 PLC ± - 1 PLC ± 0.3 2 PLC ± 0.2 3 PLC ± 0.1 4 PLC ± - ANGLES ± 5°		APVD WH	29DEC2020	NAME EP-SMA,PLUG,STRAIGHT,27GHz, SOLDER,MATCH WITH 141 CABLE		
MATERIAL SEE TABLE		FINISH -	PRODUCT SPEC 108-160152	SIZE A2	CAGE CODE 00779	DRAWING NO C=2081886
		WEIGHT 6.8g	APPLICATION SPEC -	RESTRICTED TO -	SCALE 10:1	
		CUSTOMER DRAWING		SHEET 1 of 2	REV A	

REVISIONS				
P	LTR	DESCRIPTION	DATE	APVD
-	-	SEE SHEET 1	-	-

EP-SMA CONNECTOR(2081886-1) INSTALLATION MANUAL

1. A. Strip the cable according to the size shown in the left drawing. be careful not to cut into the outer shield.
- B. Soak the outer shield of the cable in tin.
- C. After leaching, peel off the center conductor and proceed with the center conductor C0.30 chamfering, and finally the remaining sheath and outer shielding remove from the central conductor. place the sleeve over the cable. Remove from the central conductor.
- D. Place the sleeve over the cable.

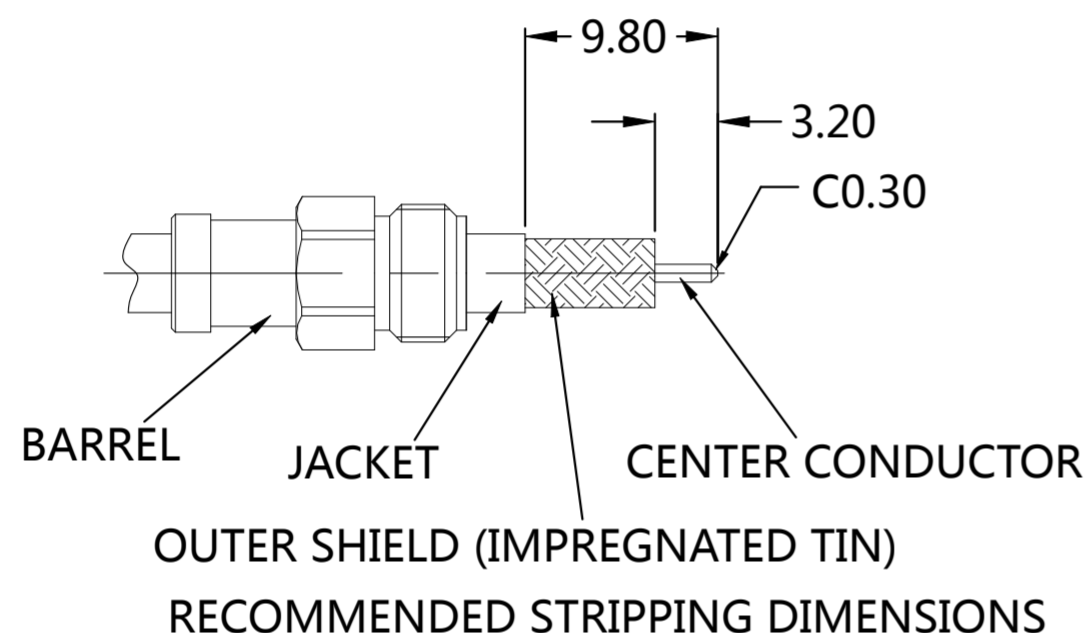

2. A. As shown in the left figure, put the welding cup on the outer shielding layer of the cable first.
- B. When welding the cup, control the end surface of the cup with a fixture parallel to the outer shielding end face of the cable.
- C. Control welding time and temperature, and remove excess with tools make sure the surface of the solder cup is smooth and clean when the solder cup is spilled excess residue in welding area.

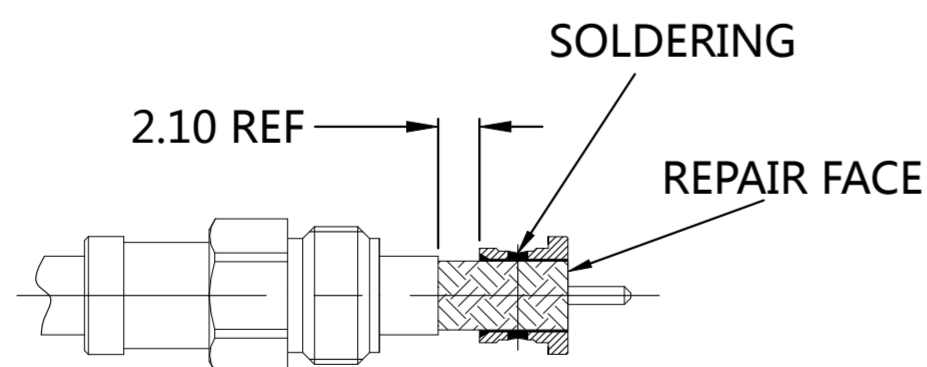

- 3.A. As shown in the figure on the left, first attach the insulator to the outer shield and put it on on the center conductor of the cable, and then attach the center pin to the insulator, weld to the center conductor of the cable.
- B. Control the welding time and temperature, and remove the excess with tools spill the tin spots, make sure the center needle surface is smooth, then clean the welding area of excess residue. excess residue in welding area.

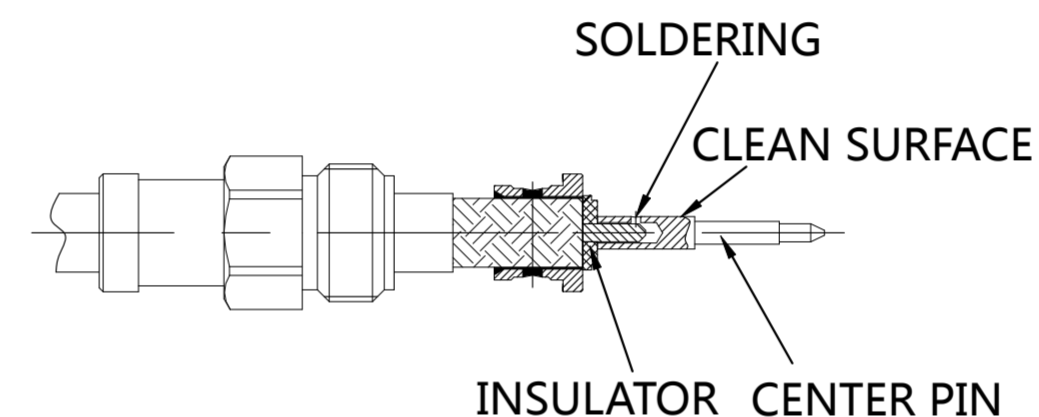

- 4.A. Insert the cable into the main body until it reaches the end face of the insulator on the cable contact with the insulator step inside the main body and cannot be pushed until.
- B. As shown in the left figure, screw the sleeve into the main body and tighten it. clean the welding area of excess residue. excess residue in welding area.

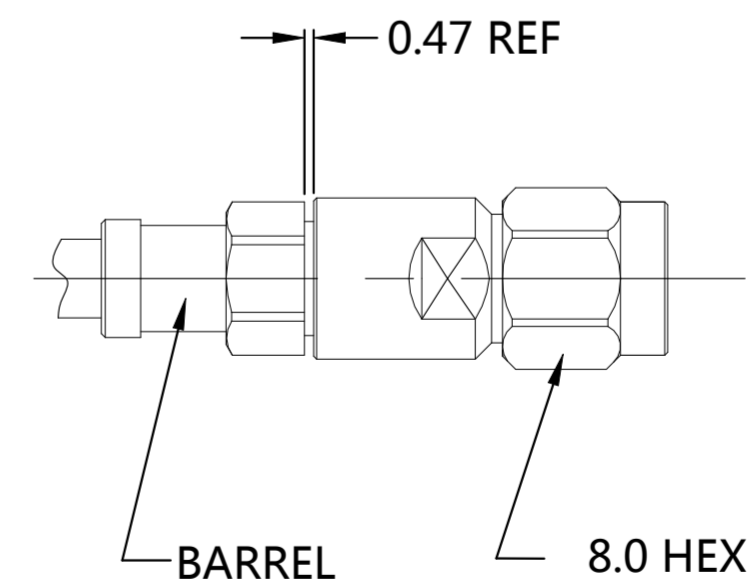

THIS DRAWING IS A CONTROLLED DOCUMENT.		DWN ED 29DEC2020		
DIMENSIONS: mm		CHK RZ 29DEC2020		
TOLERANCES UNLESS OTHERWISE SPECIFIED:		APVD WH 29DEC2020	NAME EP-SMA, PLUG, STRAIGHT, 27GHz, SOLDER, MATCH WITH 141 CABLE	
0 PLC ± -		PRODUCT SPEC	SIZE A2	CAGE CODE 00779
1 PLC ± 0.3		APPLICATION SPEC	DRAWING NO C=2081886	RESTRICTED TO -
2 PLC ± 0.2		WEIGHT -	SCALE 10:1	SHEET 2 OF 2
3 PLC ± 0.1		CUSTOMER DRAWING	REV A	
4 PLC ± -				
ANGLES ± 5°				
FINISH -				
MATERIAL SEE TABLE				