

REVISIONS					
REV	ECO	DESCRIPTION	DATE	BY	APPR
B1	-	RELEASED DRAWING	July-04-2014	Ben	Tommy
B2	-	MODIFY THE INSERT LETTER LOCATION	May-20-2016	Ben	Tommy
B3	-	ADAPT TO CHANGE OF WIRE DIAMETER	Jan-7-2020	Ronald	Tommy
B4	-	VOLTAGE UPDATE AND ADD KEY ICON	Nov-28-20	Ronald	Tommy

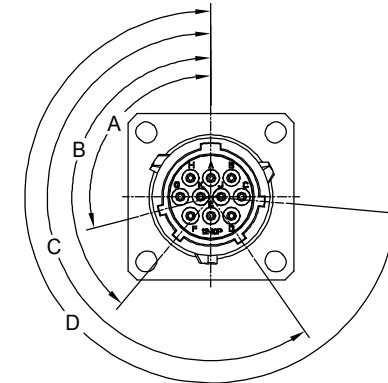
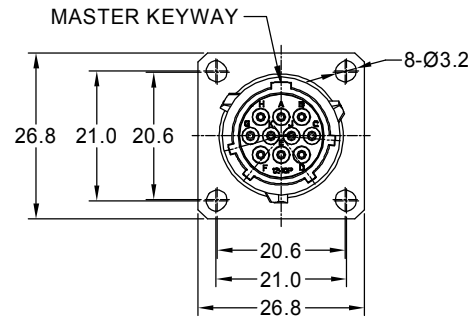
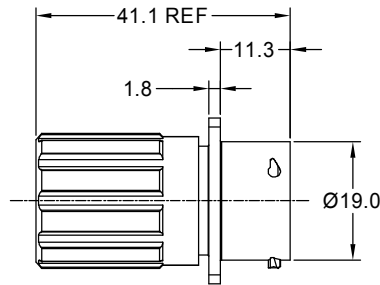

NOTES : (UNLESS OTHERWISE SPECIFIED)

1. MATERIAL :

- SHELL : ZINC ALLOY , NICKEL PLATED.
- INSERT : THERMOPLASTIC , UL94 V-0.
- END CAP : THERMOPLASTIC , UL94 V-0.
- SEAL GASKET : NBR/SILICONE RUBBER.
- O-RING : NBR/SILICONE RUBBER.
- WIRE SEAL : SILICONE RUBBER.
- PLASTIC BUSHING : THERMOPLASTIC , UL94 V-0.

2. SPECIFICATIONS :

- 2.1 RATED CURRENT :
  - 2.1.1 STAMPED CONTACT 5A (MAX).
  - 2.1.2 MACHINED CONTACT 7.5A(MAX).
- 2.2 RATED VOLTAGE : 250V ( AC/DC ) .
- 2.3 OPERATING TEMPERATURE : SEE CHART.
- 2.4 DIELECTRIC WITHSTANDING VOLTAGE : LESS THAN 2 MILLIAMPS CURRENT LEAKAGE@1500 VOLTS AC.
- 2.5 INSULATION RESISTANCE : 5000 MEGOHMS MIN.
- 2.6 IP--CLASS : IP67 (MATED CONDITION).
- 2.7 MATING CYCLES DURABILITY : 500 CYCLES(MIN).
- 2.8 ROHS COMPLIANT.

3. SUITABLE CONTACTS : 20# CONTACTS.

4. ALL DIMENSIONS ARE FOR REFERENCE USE ONLY.

5. CONTACT SIZE AND REAR SEAL WIRE RANGE :

CONTACT SIZE	MIN. INSUL O.D.	MAX. INSUL O.D.	WIRE RANGE
20#	Ø1.4mm	Ø2.1mm	20 - 30AWG

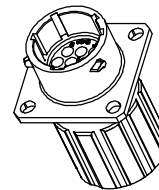
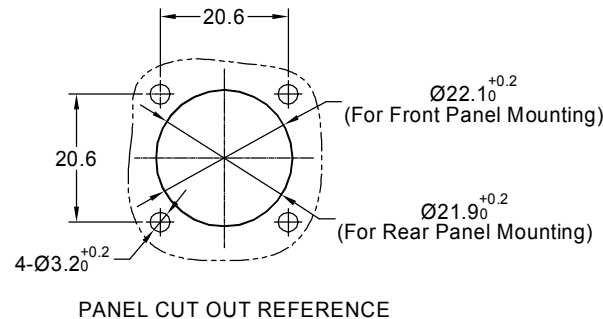

KEY POS	PART NUMBER					
	-40°C ~ 105°C	-40°C ~ 125°C	A	B	C	D
N	RT0W01210PNHEC	RT0W01210PNHEC03	105°	140°	215°	265°
W	RT0W01210PWHEC	RT0W01210PWHEC03	60°	140°	215°	265°
X	RT0W01210PXHEC	RT0W01210PXHEC03	105°	155°	215°	265°
Y	RT0W01210PYHEC	RT0W01210PYHEC03	105°	140°	225°	265°
Z	RT0W01210PZHEC	RT0W01210PZHEC03	105°	140°	215°	295°

QUANTITY	SEE PART NUMBER CHART	DESCRIPTION	ITEM
<b>MATERIALS LIST</b>			
<b>UNLESS OTHERWISE SPECIFIED</b> 1) All dimensions are in metric(mm). 2) Tolerances are as follows: 1 PL DEC ±0.30 2 PL DEC ±0.15 3 PL DEC ±0.08 Fractions ±1/64 Angles ±1° 3) Note reference =		<b>SIGNATURES</b> DRAWN: <b>Ronald</b> Nov-28-20 CHECKED: <b>Flan</b> Nov-28-20 ENGINEER: APPROVAL: <b>Tommy</b> Nov-30-20 CUSTOMER:	 Sine Systems - www.amphenol-sine.com 44724 Morley Drive Clinton Township, MI 48036
MATERIAL SPECIFICATIONS: PROCESS SPECIFICATIONS: NEXT ASSY:		THIS DRAWING IS SUPPLIED FOR INFORMATION ONLY. DESIGN FEATURES, SPECIFICATIONS AND PERFORMANCE DATA SHOWN HEREON ARE THE PROPERTY OF THE AMPHENOL CORPORATION. NO RIGHTS OF REPRODUCTION ARE IMPLIED. ALL DIMENSIONS ARE SUBJECT TO NORMAL MANUFACTURING VARIATIONS.	ECOMATE RM, RECEPTACLE, 10POS, SIZE 12, PIN, END CAP. SIZE: <b>B C-</b> DWG NO: <b>RT0W01210P*HEC</b> REVISION: <b>B4</b> SCALE: NONE SHEET 1 OF 1

TITLE: ECOMATE RM, RECEPTACLE, 10POS, SIZE 12, PIN, END CAP DWG NO: RT0W01210P\*HEC REV: B4 SH: 1 OF: 1