

REVISIONS					
REV	DATE	DESCRIPTION	BY	CHK	APPV
M4	18OCT2021	REVISED PER ECN-21-122181	RZ		WK

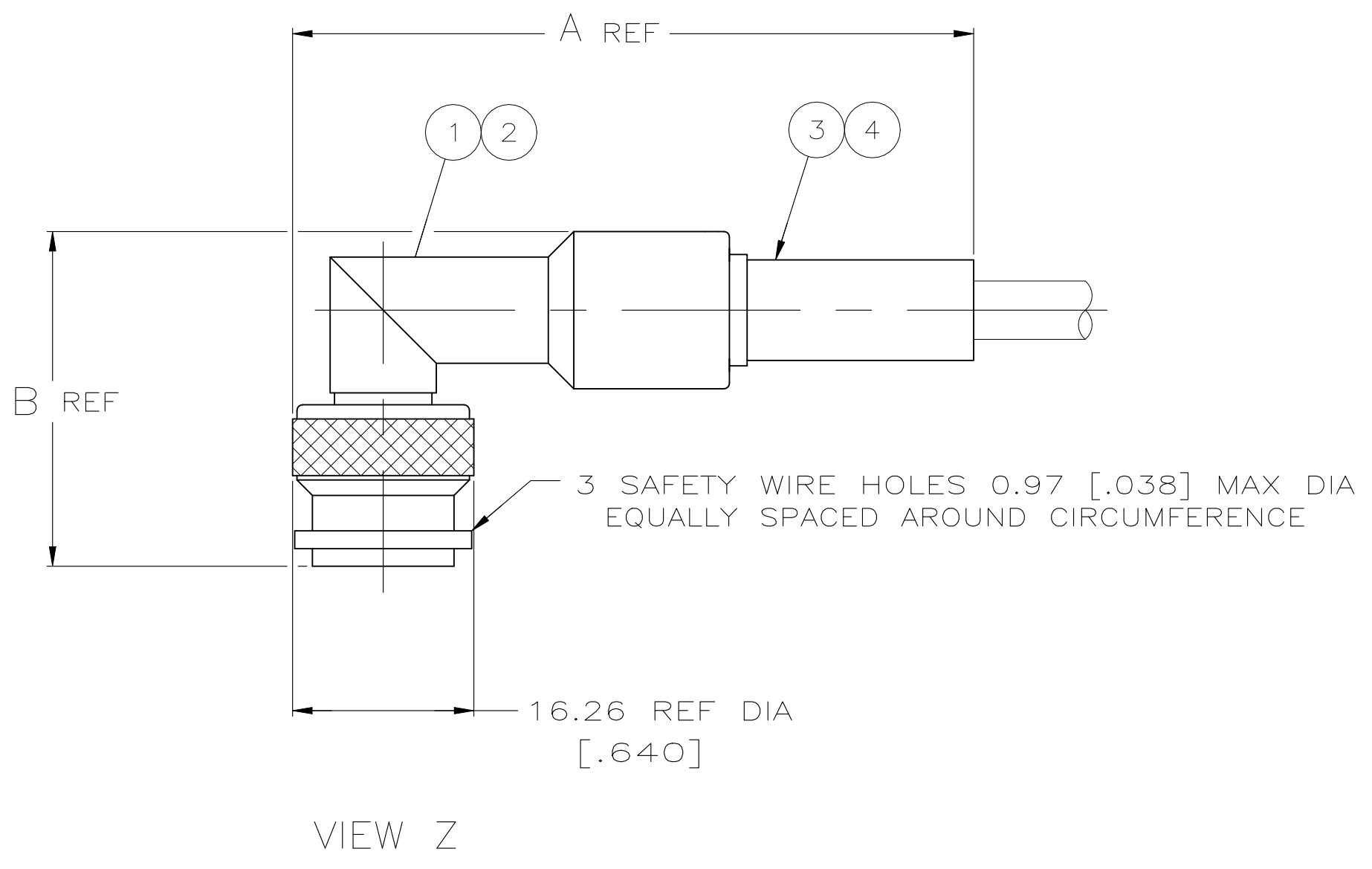

FELECA F1703/94 AND FILOTEX 50 MFCFB

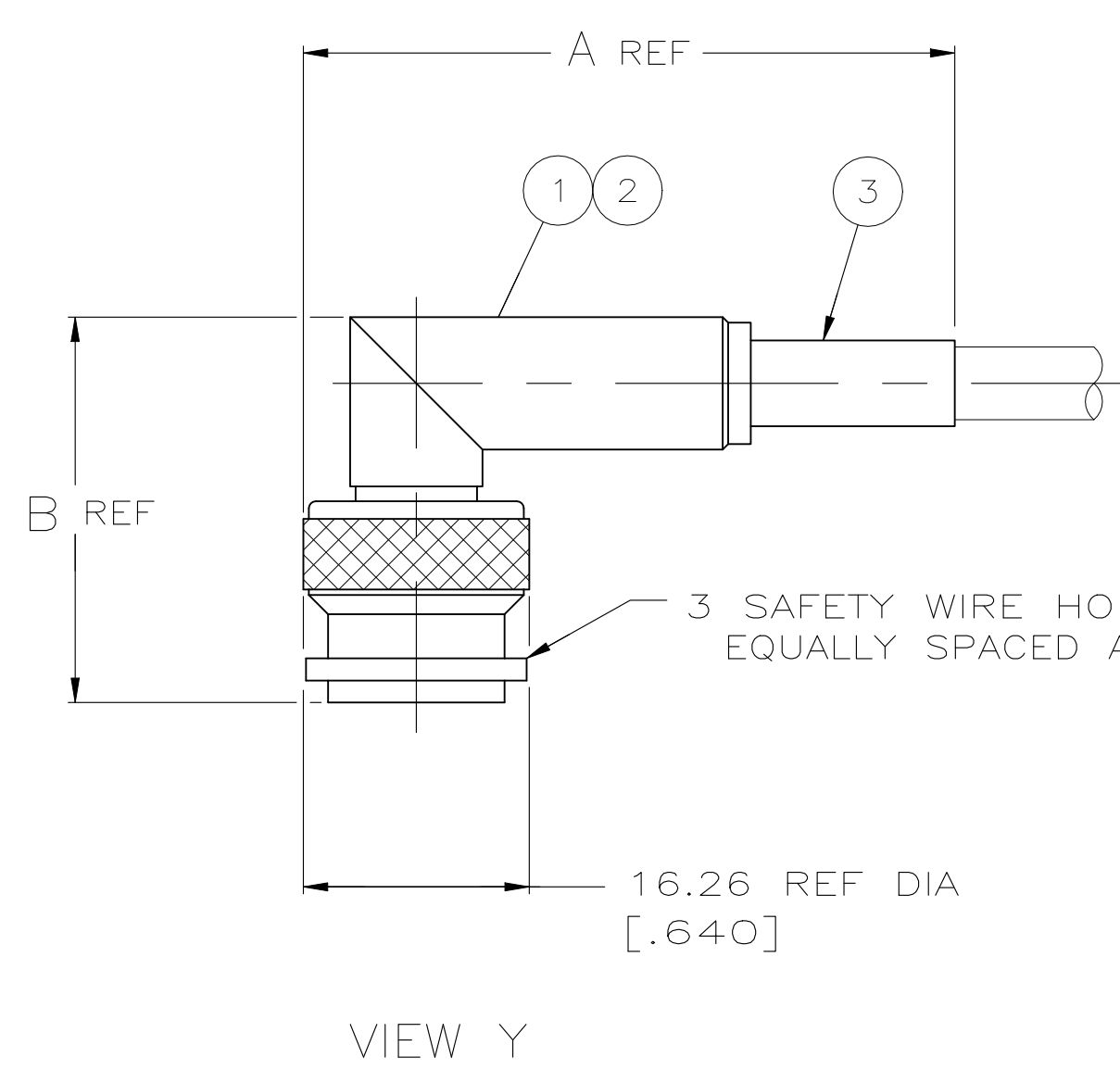
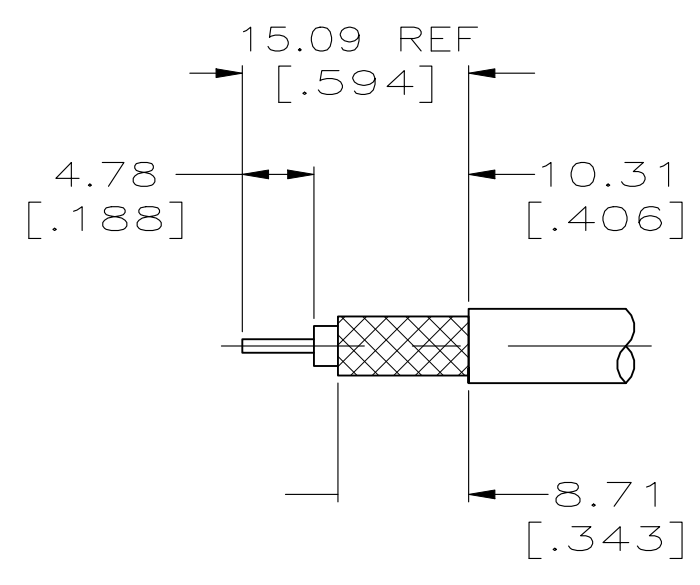

VIEW U
RECOMMENDED
STRIP LENGTH

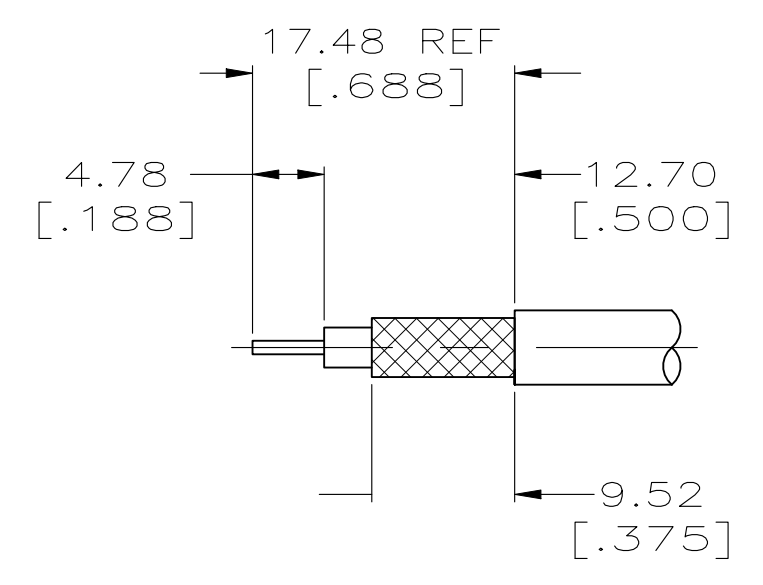

VIEW V
RECOMMENDED
STRIP LENGTH

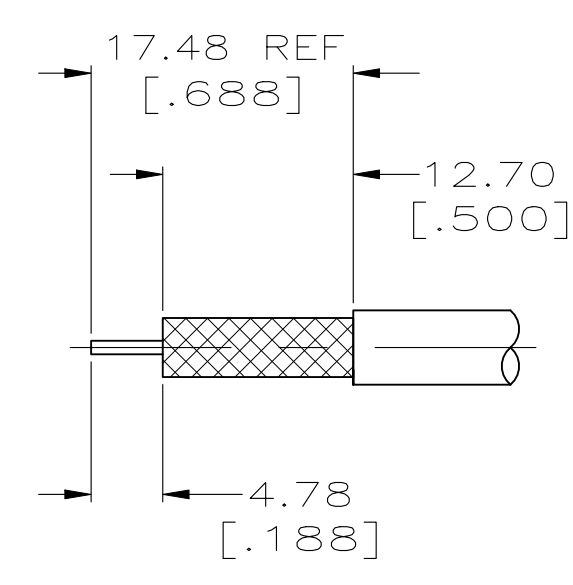

VIEW W
RECOMMENDED
STRIP LENGTH

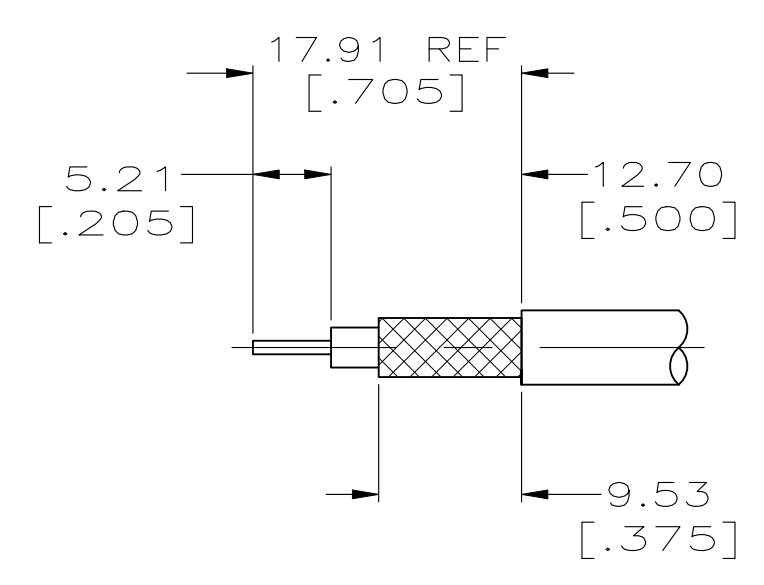

VIEW X
RECOMMENDED
STRIP LENGTH

SUPERSEDED BY 1-5225349-1														
SUPERSEDED BY 5225349-9	RG-9/U,9A/U & 214/U	220015-6	29.97 [1.180]	57.15 [2.250]	X AND Z	225908-1	9-331256-0	225471-7	5-225518-4	1-225349-1				
SUPERSEDED BY 225559-8	RG-8/U,8A/U & 213/U	220015-1	29.97 [1.180]	59.51 [2.343]	W AND Z	-	9-51713-4	225599-1	225518-3	225349-9				
SUPERSEDED BY 225554-6	RG-142/U,142A/U & 142B/U	220015-1	26.57 [1.046]	59.51 [2.343]	V AND Z	-	51713-2	225599-1	225518-3	225349-8				
	OBSOLETE RG-141/U & 141A/U	220045-2	30.94 [1.218]	46.81 [1.843]	U AND Y	-	225382-2	225471-3	225518-1	225349-6				
SUPERSEDED BY 225554-3	RG-59B/U & 62B/U	220045-2	30.94 [1.218]	46.81 [1.843]	U AND Y	-	225381-2	225471-3	225518-1	225349-5				
SUPERSEDED BY 225554-2	RG-58/U,58A/U,58B/U & 58C/U	220045-3	30.94 [1.218]	42.85 [1.687]	U AND Y	-	50428-1	225471-2	225518-2	225349-3				
SUPERSEDED BY 225554-1	RG-55/U,55A/U,55B/U & 223/U	220045-2	30.94 [1.218]	46.81 [1.843]	U AND Y	-	50427-1	225471-1	225518-1	225349-2				

CABLE SIZE	CRIMP TOOL	B	A	VIEW	④ SEAL QTY=1	③ FERRULE QTY=1	② CONTACT QTY=1	① PLUG ASSY QTY=1	PART NUMBER
------------	------------	---	---	------	-----------------	--------------------	--------------------	----------------------	-------------

THIS DRAWING IS A CONTROLLED DOCUMENT.

DIMENSIONS: mm [INCHES]	TOLERANCES UNLESS OTHERWISE SPECIFIED:	DIN B. SCOTT 07-22-91	APPROVED M. PHILLIPS 9-13-91	NAME
0. PLC ± -	1. PLC ± -	8-20-91		
2. PLC ± 0.41 [0.016]	3. PLC ± -			
4. PLC ± -	ANGLES ± -			

MATERIAL: - FINISH: -

WEIGHT: 0.000000

CUSTOMER DRAWING

SCALE: 2:1 SHEET 1 of 1 REV M4

TE Connectivity

PLUG, RIGHT ANGLE, SERIES TNC

408-2299-5

00779C=225349