

THIS DRAWING IS UNPUBLISHED. RELEASED FOR PUBLICATION
 © COPYRIGHT - By - ALL RIGHTS RESERVED.

LOC	DIST	REVISIONS					
AF	50	P	LTR	DESCRIPTION	DATE	DWN	APVD
		S1		REVISED PER ECR-14-007779	28MAY2014	GRZ	JL

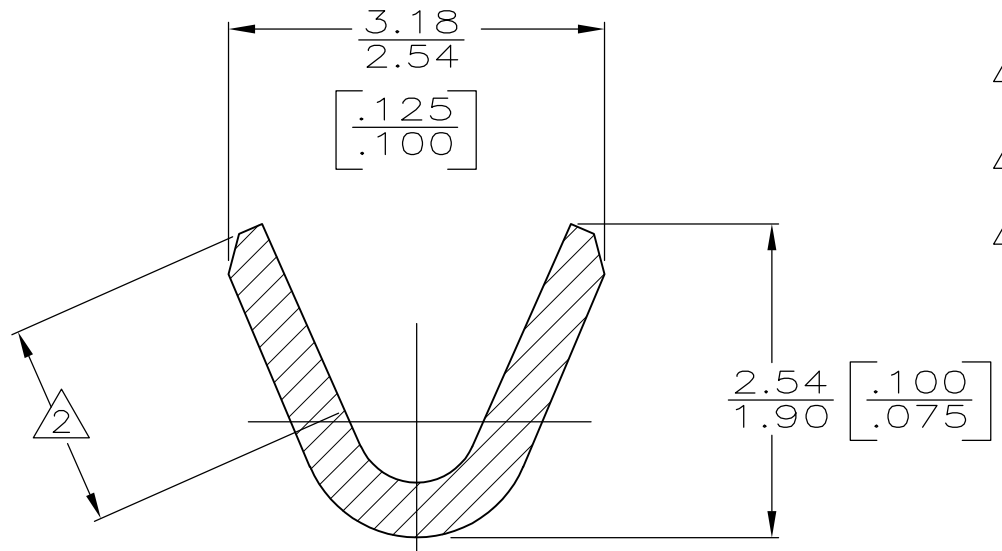

SECTION A-A
SCALE 20:1

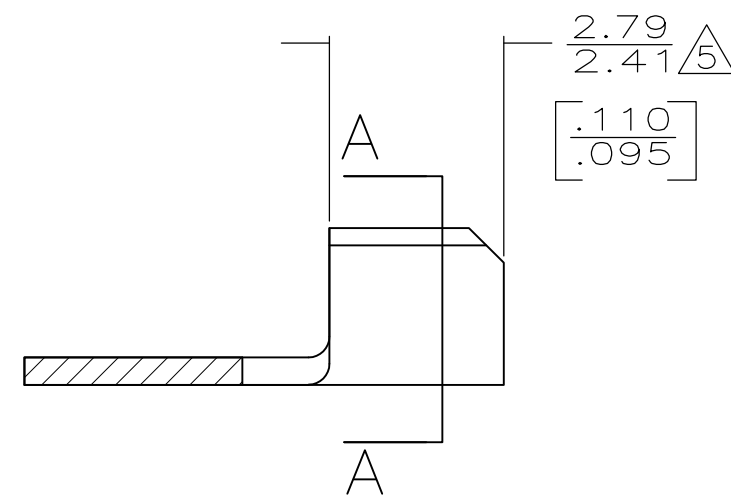
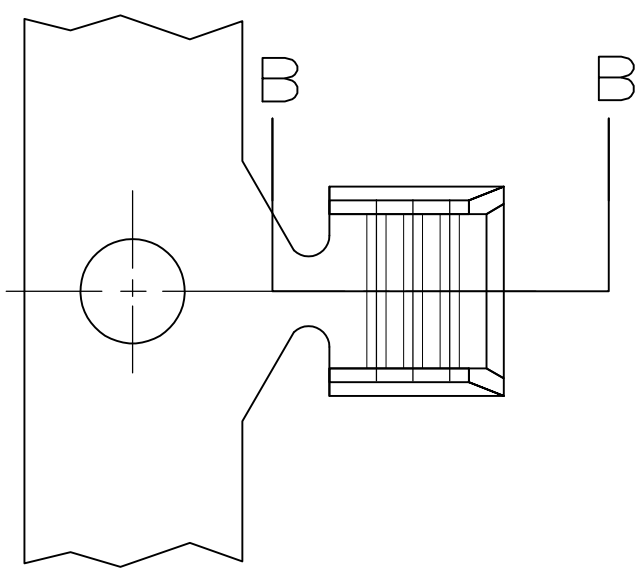
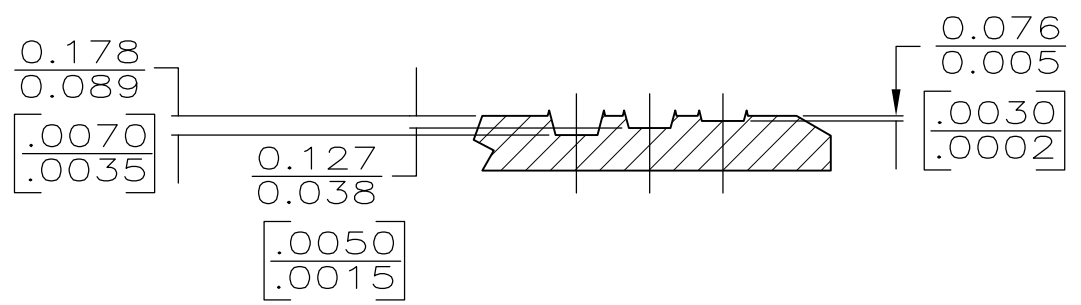

SECTION B-B
SCALE 20:1

- 1 CONTINUOUS STRIP ON REEL.
- 2 SERRATION DEPTH SHOULD BE MEASURED IN AN AREA FREE FROM FORMING.
- 3 0.00254 [.000100] MIN TIN PLATE.
- 4 0.0038 [.000015] MIN GOLD PLATE OVER 0.00127 [.000050] MIN NICKEL UNDERPLATE.
- 5 GOLD PLATE IS ON WIRE BARREL ONLY.
- 6 REELING: PLASTIC REELS.
- 7 PREPRODUCTION - FASR REQUIRED.
- 8 CRIMP WIDTH 1.78 [.070], F (AMPLIVAR TYPE)
 CRIMP HEIGHT ±0.05 [.002] =
 (TOTAL CMA + 5,000) / 129,000
 GENERAL APPLICATION GUIDELINES MUST BE FOLLOWED AS SPECIFIED IN CATALOG #82221
 FOR APPLICATOR INFO CALL, 1-800-722-1111
 FOR PRODUCT INFO CALL, 1-800-522-6752

	REVERSE		62194-6
TIN PLATE	STANDARD		62194-5
	STANDARD	400-1300 CMA	62194-4
	REVERSE		62194-3
TIN PLATE	STANDARD		62194-2
			62194-1
FINISH	REELING	WIRE RANGE	PART NO

THIS DRAWING IS A CONTROLLED DOCUMENT.

DIMENSIONS: INCHES	TOLERANCES UNLESS OTHERWISE SPECIFIED:	DWN PHIL FORTNEY 7/27/93	TE Connectivity
	0 PLC ± -	CHK MS FEHER 7/27/93	
	1 PLC ± -	APVD D SCHWENK 7/27/93	
	2 PLC ± 0.25 [.010]	NAME	SPLICE, AMPLIVAR™ MINIATURE
	3 PLC ± -	PRODUCT SPEC	
	4 PLC ± -	APPLICATION SPEC	
	ANGLES ± -	WEIGHT	SIZE CAGE CODE DRAWING NO RESTRICTED TO
MATERIAL BRASS	FINISH SEE TABLE		A3 00779 C-62194

CUSTOMER DRAWING SCALE 10:1 SHEET 1 OF 1 REV S1