

DRV5055-5057EVM

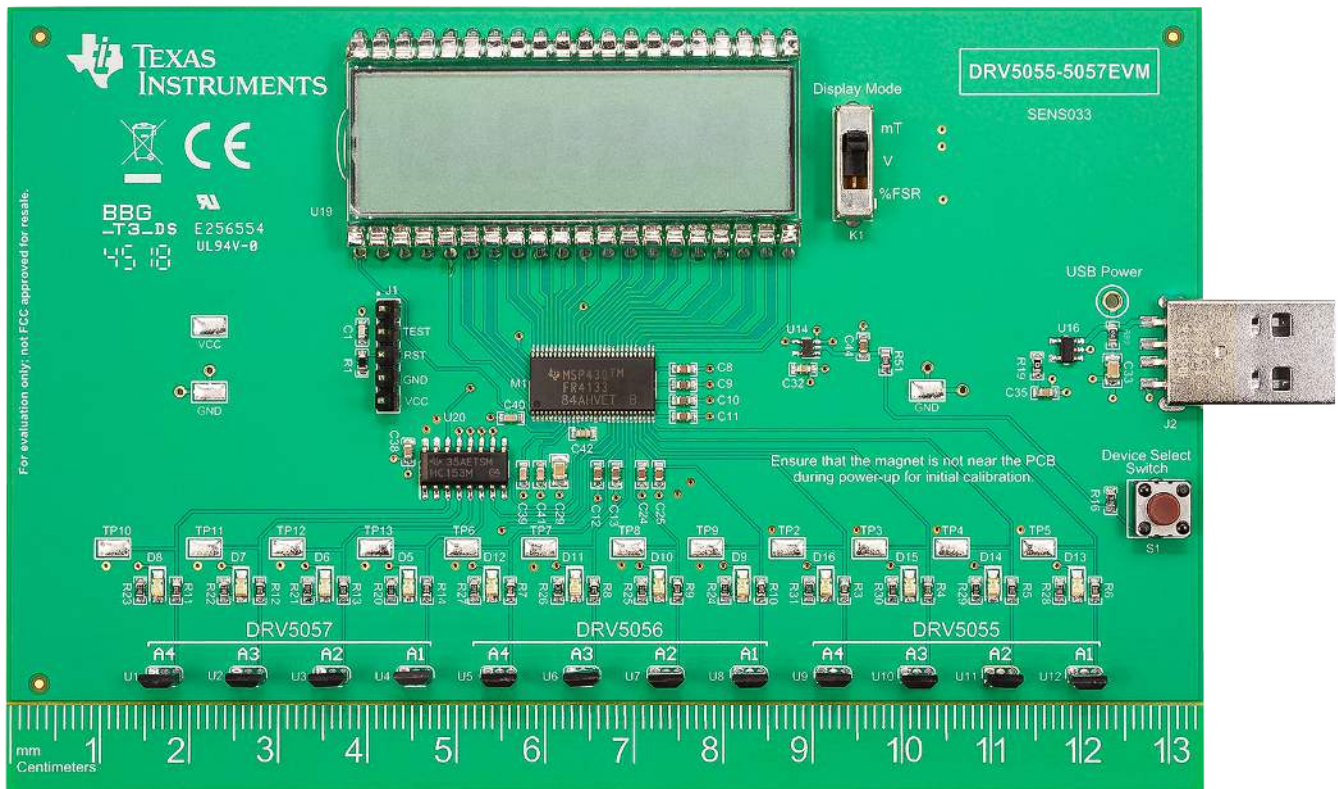

This user's guide describes the characteristics, operation, and use of the [DRV5055](#), [DRV5056](#), and [DRV5057](#) (DRV505x) evaluation module (EVM). This EVM is designed to evaluate the performance of the DRV505x ratiometric, linear, Hall effect sensors. Throughout this document, the terms evaluation board, evaluation module, and EVM are synonymous with the DRV5055-5057EVM. This document includes a schematic, reference printed circuit board (PCB) layouts, and a complete bill of materials (BOM).

Contents

1	Overview	3
2	Operation	5
3	Hardware.....	6
4	Schematics, PCB Layout, and Bill of Materials	9

List of Figures

1	Microcontroller Source Code Operation	6
2	Gain Variants A1 to A4	10
3	LCD, Microcontroller and Switch	11
4	Push-Button, Slider Switch, and Programming User Inputs	12
5	LED and Indicators, Slider Switch Status Reader, and DRV5057 Multiplexer	13
6	Supply Input and Power Conditioning	14
7	Top Overlay	15
8	Top Layer	15
9	Bottom Overlay	15
10	Bottom Layer.....	15

List of Tables

1	DRV505x Device Summary	3
2	Kit Contents	3
3	Related Documentation	4
4	Bill of Materials	16

Trademarks

All trademarks are the property of their respective owners.

1 Overview

The DRV505x family of linear Hall effect sensors sense magnetic fields ranging from 19 mT to 176 mT full scale, depending on device and supply voltage. For each device, four gains are available. These devices operate from a single 3-V to 5.5-V power supply, drawing a maximum of 10 mA of supply current. These devices are currently available in a 3-pin SOT-23 or 3-pin TO-92 package. This EVM uses a 3.3-V supply, and [Table 1](#) lists the gains at this voltage for each device.

Table 1. DRV505x Device Summary

Product	Gain at 3.3V V _{CC}
DRV5055A1	60 mV/mT
DRV5055A2	30 mV/mT
DRV5055A3	15 mV/mT
DRV5055A4	7.5 mV/mT
DRV5056A1	120 mV/mT
DRV5056A2	60 mV/mT
DRV5056A3	30 mV/mT
DRV5056A4	15 mV/mT
DRV5057A1	1.2 %D/mT
DRV5057A2	0.6 %D/mT
DRV5057A3	0.3 %D/mT
DRV5057A4	0.15 %D/mT

1.1 Kit Contents

[Table 2](#) lists the contents of the DRV5055-5057EVM kit. Contact the nearest [Texas Instruments Product Information Center](#) if any component is missing.

Table 2. Kit Contents

Item	Quantity
DRV5055-5057EVM test board	1
Cylindrical magnet	1
USB cable	1

1.2 Related Documentation From Texas Instruments

This user's guide is available from the TI website under literature number SLYU046. Any letter appended to the literature number corresponds to the document revision that is current at the time of the writing of this document. Newer revisions are available from www.ti.com or the Texas Instruments' Literature Response Center at (800) 477-8924 or the Product Information Center at (972) 644-5580. When ordering, identify the document by both title and literature number. [Table 3](#) lists documentation related to the DRV5055-5057EVM. Click the links in [Table 3](#) for further information on the DRV505x. The device name links to the product web folder on www.ti.com. The literature number links to the document PDF.

Table 3. Related Documentation

Document Title	Document Literature Number
DRV5055 data sheet	SBAS640
DRV5055-Q1 data sheet	SBAS639
DRV5056 data sheet	SBAS644
DRV5056-Q1 data sheet	SBAS643
DRV5057 data sheet	SBAS646
SN74LVC1G17 data sheet	SCES351
TCA9535 data sheet	SCPS201
LP5907 data sheet	SNVS798
TS5A23159 data sheet	SCDS201

2 Operation

2.1 Quick Start Setup

The following instructions describe how to set up and use the DRV5055-5057EVM.

- Step 1. Insert the USB cable into the EVM onboard USB receptacle.
- Step 2. For proper calibration, make certain that there are no magnets within a few feet of the EVM when the EVM powers up.
- Step 3. Plug the USB cable into any USB power adapter (for example, laptop, desktop, power bank, and so on). LED D13 on the far bottom right of the board indicates the board is powered, calibrated, and is taking sample measurements from the DRV5055A1 (default EVM startup device).

2.2 Measurements

The DRV5055-5057EVM measures a magnetic field with multiple devices and the respective gain variants. Push-button S1 selects the different gain variants of the DRV505x devices. The devices are arranged such that gain variants increase sequentially from right to left, and the device families (DRV505x) are also arranged in an increasing order from right to left. The LCD displays the measurement corresponding to the selected device. The measurement format is adjusted by the slide switch labeled *Display Mode* (K1).

- Step 1. Click the *Device Select Switch* until an LED indicates the device of interest is selected.
- Step 2. Adjust the *Display Mode* slide switch to the measurement format of interest. Voltage mode (labeled V) is blank for the DRV5057 devices.
- Step 3. Introduce magnetic stimulus (for example, the magnet included in the evaluation kit).

3 Hardware

The DRV505x is a linear Hall effect magnetic-sense solution that provides ease of use and high performance. The DRV5055-5057EVM is intended to provide basic functional evaluation of this device family. The fixture layout is not intended to be a model for the target circuit, nor is it laid out for electromagnetic compatibility (EMC) testing. The DRV5055-5057EVM consists of one PCB with each of the gain variants of the DRV5055, DRV5056, and DRV5057. The EVM kit also provides a USB cable for quick power-up, as well as a magnet for quick qualitative assessment of the DRV505x variants performance.

3.1 Features

The layout of the DRV5055-5057EVM printed circuit board (PCB) is designed to provide the following features:

- Evaluation of all gain options for the DRV505x
- Easily access device pins through test points
- Easily read voltage, mT, % duty cycle values, and microcontroller ADC memory values from the onboard LCD, where applicable
- Toggle between devices with a press of the *Device Select Switch*, push-button S1.

See the links in [Table 3](#) for comprehensive information about the DRV505x family of devices.

3.2 Theory of Operation

The DRV5055-5057EVM is a plug-and-play board, requiring only that the user supply power and provide a magnetic stimulus after the initial calibration. The ease of operation can be attributed to the onboard microcontroller. The source code for the microcontroller is available on the [DRV5055](#), [DRV5056](#), and [DRV5057](#) web folders under *Tools and Software*. The basic operation of the microcontroller source code is outlined in the state machine diagram shown in [Figure 1](#). Upon receiving power, the microcontroller registers are set up to properly interact with the other devices on the board. Then, a preliminary measurement of each DRV5055, DRV5056, and DRV5057 gain variant is taken. Make sure that the magnetic stimulus of interest is not present at this time because this measurement sets the 0 point in the mT measurement display. After calibration is complete, the LED for the DRV5055A1 powers on by default. At this point, the EVM microcontroller begins continuously sampling the DRV5055A1. Pressing push-button S1 results in the EVM sampling the next adjacent device. After every 32 samples are taken, the device calculates an average, and processes the data to fit the format selected by the slider switch K1.

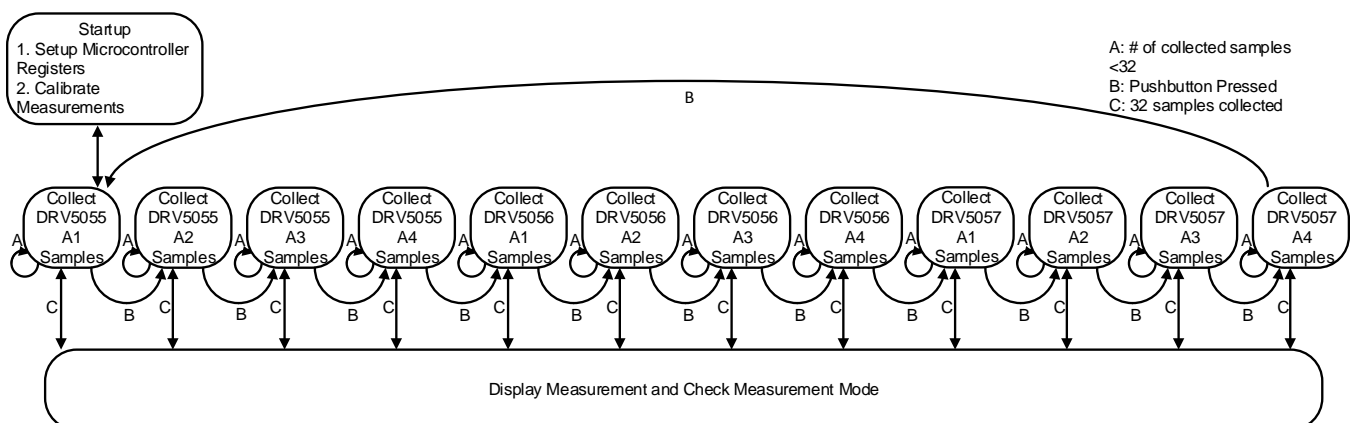

Figure 1. Microcontroller Source Code Operation

3.3 Circuitry

This section summarizes the DRV5055-5057EVM components.

3.3.1 C1, J1, R1, and R2

J1 serves as the connector for an external MSP-FET Flash Emulation Tool to connect to the board.

C1, R1, and R2 are the additional passives required for the emulation tool to effectively communicate with the MSP430FR4133 for the purposes of programming and debugging.

The MSPFETFlash can be obtained separately at <http://www.ti.com/tool/MSP-FET>. Alternatively, if an MSP430FR4133 Launchpad (or compatible device) is already available, that board can be configured to program the DRV5055-5057EVM microcontroller.

3.3.2 C2-C7, C14-C19, C29, C32, C33, C36, C38, C43

C2-C7 and C14-C19 are the 1- μ F supply bypass capacitors for the DRV505x.

C29, C32, C33, C36, C38, and C43 are the supply bypass capacitors for the MSP430FR4133, SN74LVC1G17, LP5907MFX-3.3, TCA9535, CD74HC153M96, and TS5A23159, respectively.

3.3.3 C8-C13, C24, C25, R3-R10

These components are used to form low-pass filters on the outputs of all of the DRV5055Ay and DRV5056Ay devices, where $y = 1$ to 4. The capacitors also allow the ADC input node to remain relatively stable throughout the ADC sample transition. R11-R14 are used to condition the PWM output of the DRV5057Ay devices.

3.3.4 J2

J2 is the male USB connector that allows the device to be powered through a PC USB port or USB adapter.

3.3.5 K1, R47, R48, R49

K1 serves as a slide switch that pulls GPIO extender TCA9535 GPIO pins P00, P01, and P02 either to GND or to 3.3-V VCC through pullup resistors R47, R48, and R49.

3.3.6 R16 and S1

R16 is a pullup resistor that ties push-button switch S1 to the 3.3-V VCC when S1 is not pushed.

3.3.7 C55, R51, and U14

C55 and R51 form a low-pass filter with the push-button stimulus, and are used with SN74LVC1G17 Schmitt Trigger (U14) to mitigate the effects of bounce from the push-button.

3.3.8 U1-U4, U5-U8, U9-U12

U1 to U4 correspond to each of the gain variants of the DRV5057 device. The gains are arranged highest to lowest with U1 being the A4 variant while U4 is the A1 variant. U5 to U8 correspond to each of the gain variants of the DRV5056 device. The gains are arranged highest to lowest with U5 being the A4 variant while U8 is the A1 variant. U9-U12 correspond to each of the gain variants of the DRV5055 device. The gains are arranged highest to lowest with U9 being the A4 variant while U12 is the A1 variant.

3.3.9 U16 C33, C35, R19, R50

U16 is the LP590MFX-3.3 low dropout regulator (LDO) that converts the input voltage from the USB power source to a stable 3.3 V.

3.3.10 U17, R20-R46, D5-D16

U17 is the TCA9535 GPIO extender. This particular device is used to compliment the MSP430FR4133IG56R that by itself has an insufficient number of pins to perform all tasks required by the board. The MSP430FR4133 and TCA9535 communicate through the I²C protocol, which requires pullup resistors R32 and R33. The TCA9535 is the slave device, whereas the MSP430FR4133 is the master device.

U16 communicates the K1 state on pins P00, P01, and P02 to the MSP430FR4133.

Pins P03-P07 and P10-P16 are defined as outputs for toggling LEDs D5-D16 according to commands from the MSP430FR4133.

Resistors R20-R31 are 10-kΩ resistors meant to limit current through LEDs D5-D16 when a corresponding TCA9535 output pin is toggled low.

Resistors R35-R46 are for power saving when any the corresponding TCA9535 output pin is high.

By default, TCA9535 GPIOs are all disabled and thus to enable these GPIOs the 10-kΩ, R34, ties pin 1 to 3.3-V VCC.

3.3.11 U19

U19 is the VI-401-DP-RC-S LCD that displays the measurements of a selected device for a given selected measurement format.

3.3.12 U20

U20 is the CD74HC153M96 dual 4-1 multiplexer used to switch between the outputs of DRV5057Ay devices. The selected output is then fed through to the MSP430FR4133.

3.3.13 M1, C49-C42

M1 is the MSP430FR4133 that samples the analog output from the DRV505x and converts those outputs into a bit pattern that conveys the correct output measurement on the LCD display. M1 uses capacitors C49-C42 to convert the input voltage to a boosted square wave output signal capable of driving the LCD display. M1 also gathers information from push-button S1, U17, the signal fed through U20, and signals from U5-U12. M1 also commands U17 to turn on the LEDs of interest.

3.3.14 U21

U21 is a switch that serves as a GPIO extender to provide on additional pin with a voltage signal suitable for the LCD.

4 Schematics, PCB Layout, and Bill of Materials

NOTE: Board layouts are not to scale. These figures are intended to show how the board is laid out. The figures are not intended to be used for manufacturing DRV5055-5057EVM PCBs.

4.1 Schematics

Figure 2 to Figure 6 show the schematic of the DRV5055-5057EVM. Figure 2 pertains to DRV505x devices that the DRV5055-5057EVM is meant to demo. Figure 3 shows the schematic of the microcontroller that does all the processing of the measurement data and user input, as well as the LCD that the microcontroller drives. Figure 4 displays the circuitry for user inputs and programming inputs. Figure 5 corresponds to the GPIO extender used for turning on the respective LED indicators and reading the status of the slider switch. Figure 6 is the schematic of the power stage used to transform the 5-V USB input to a 3.3-V supply rail for all other onboard devices.

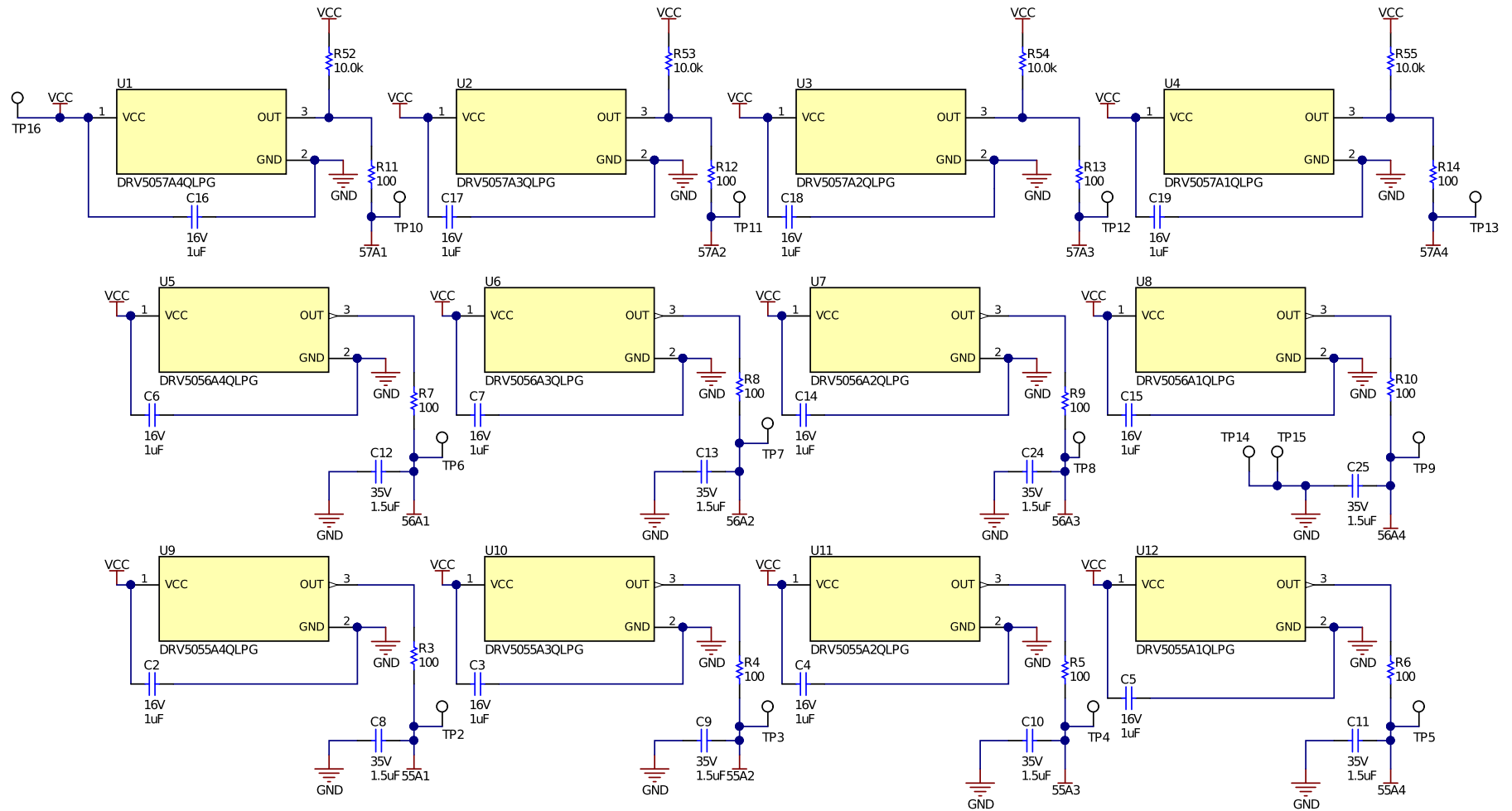

Figure 2. Gain Variants A1 to A4

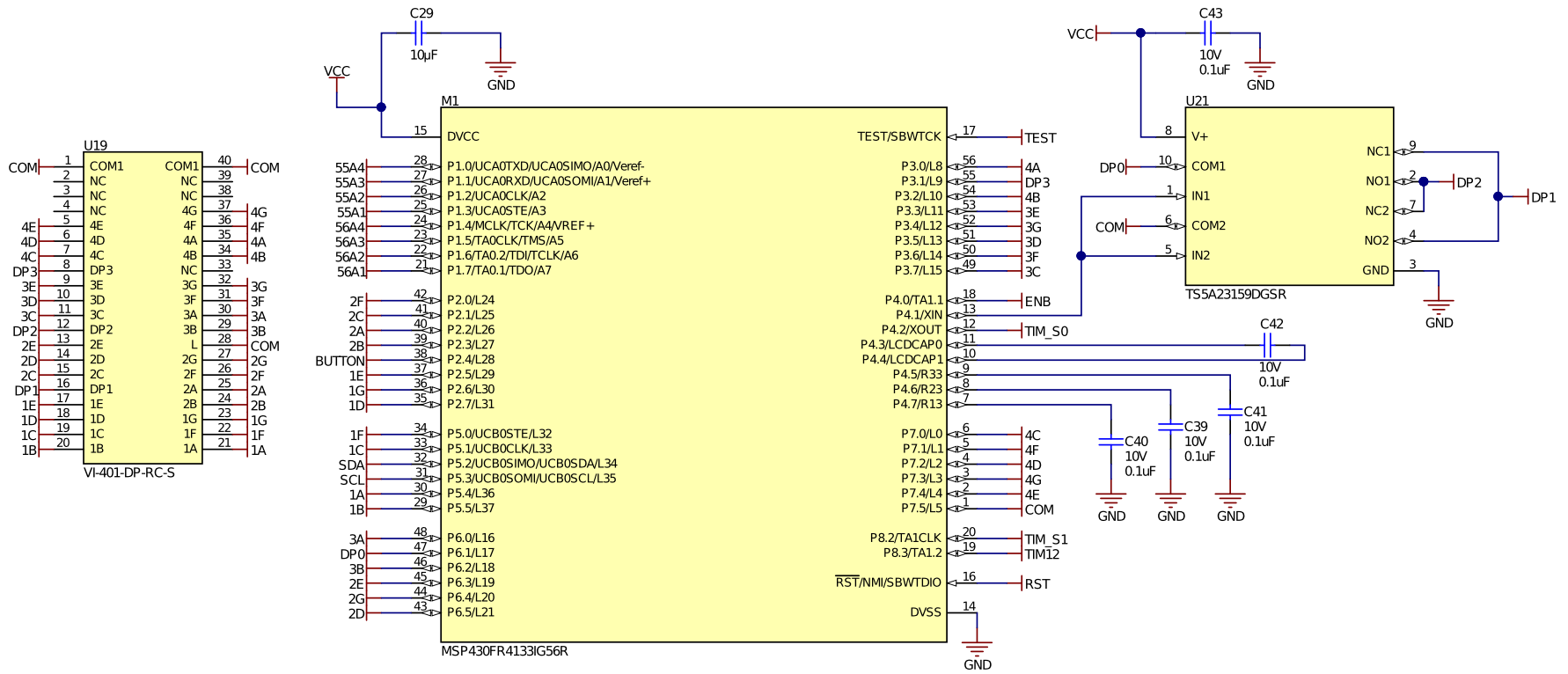

Figure 3. LCD, Microcontroller and Switch

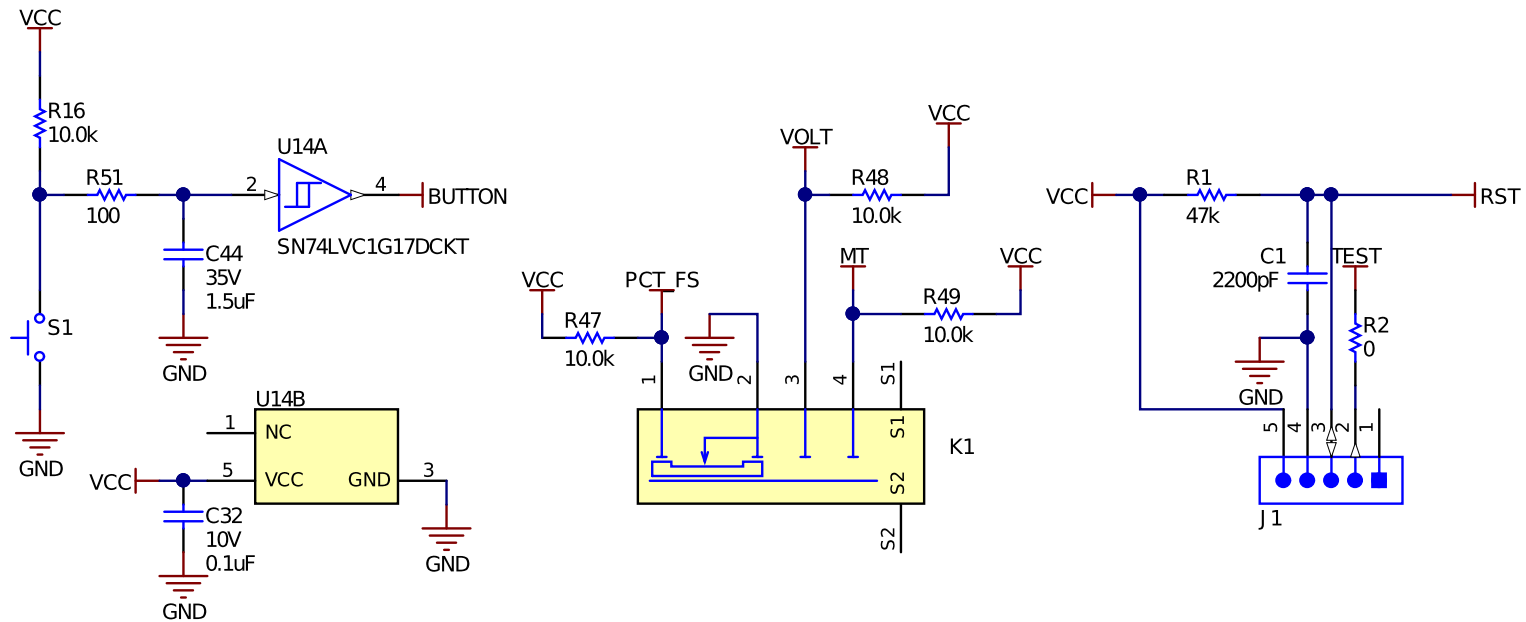

Figure 4. Push-Button, Slider Switch, and Programming User Inputs

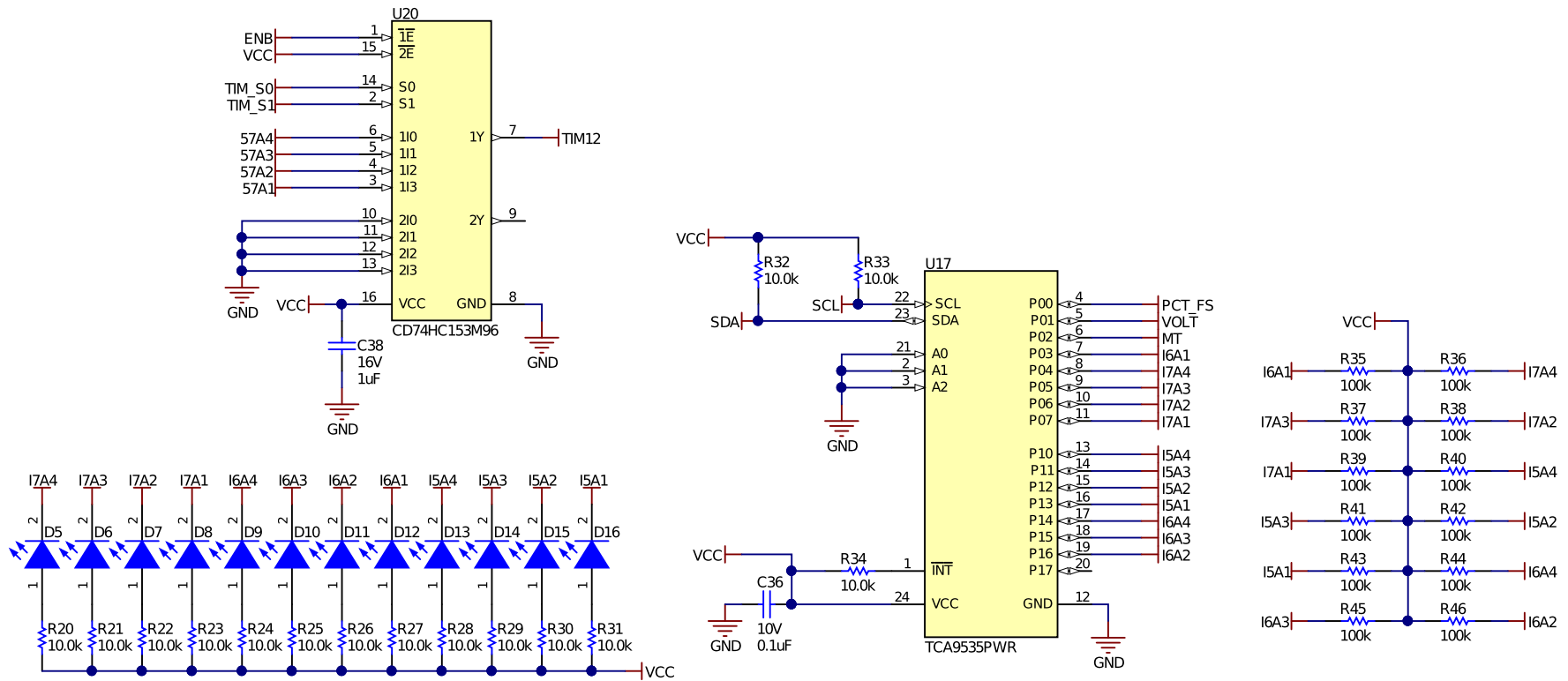

Figure 5. LED and Indicators, Slider Switch Status Reader, and DRV5057 Multiplexer

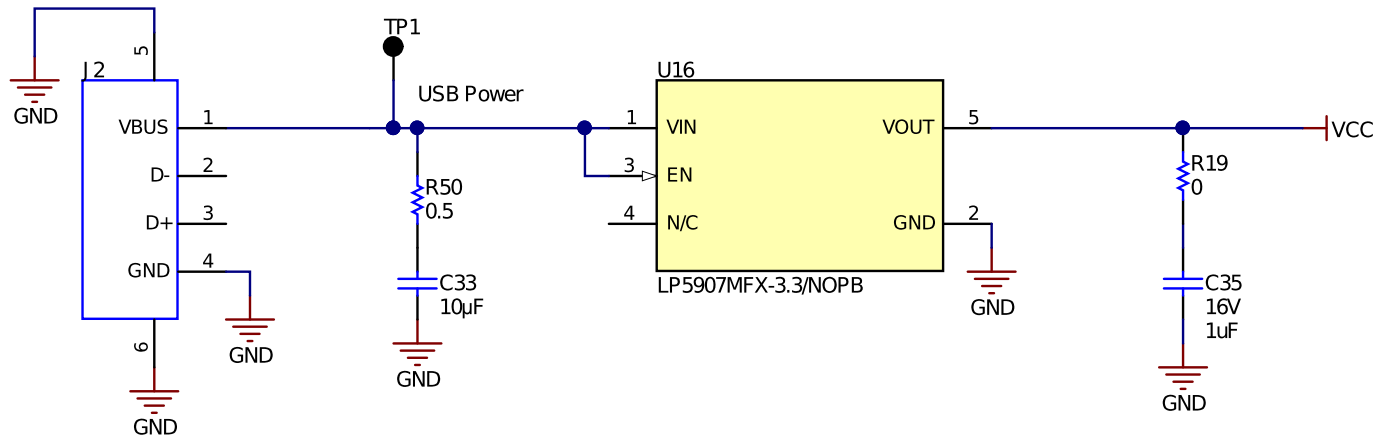

Figure 6. Supply Input and Power Conditioning

4.2 PCB Layout

Figure 7 through Figure 10 illustrate the PCB layers of the DRV5055-5057EVM.

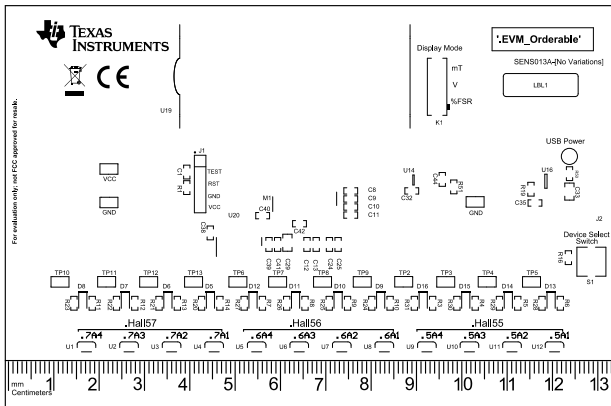

Figure 7. Top Overlay

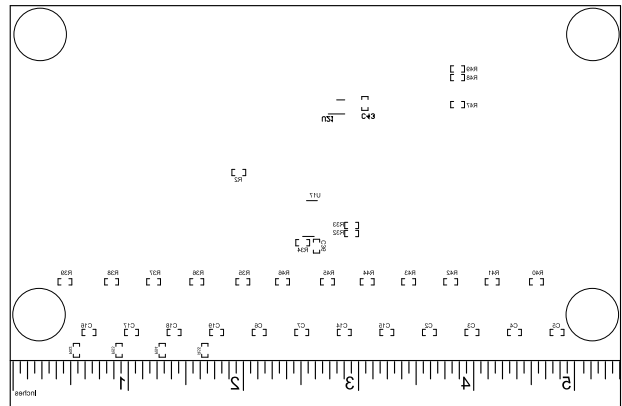

Figure 9. Bottom Overlay

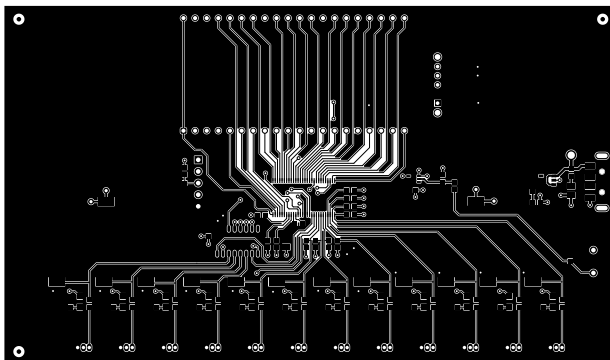

Figure 8. Top Layer

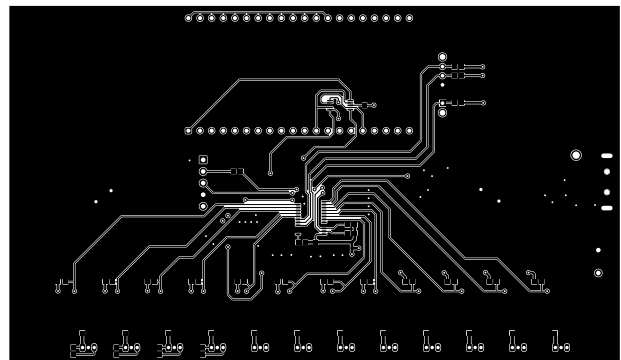

Figure 10. Bottom Layer

4.3 Bill of Materials

Table 4 provides the parts list for the DRV5055-5057EVM.

Table 4. Bill of Materials

Designator	Quantity	Value	Description	Package Reference	Part Number	Manufacturer
C1	1	2200pF	CAP, CERM, 2200 pF, 50 V, +/- 5%, C0G/NP0, 0603	0603	GRM1885C1H222JA01D	MuRata
C2, C3, C4, C5, C6, C7, C14, C15, C16, C17, C18, C19, C35, C38	14	1uF	CAP, CERM, 1 uF, 16 V, +/- 10%, X7R, 0603	0603	C1608X7R1C105K080AC	TDK
C8, C9, C10, C11, C12, C13, C24, C25, C44	9	1.5uF	CAP, CERM, 1.5 uF, 35 V, +/- 10%, X5R, 0603	0603	C1608X5R1V155K080AC	TDK
C29, C33	2	10uF	CAP, CERM, 10 uF, 16 V, +/- 10%, X7R, 0805	0805	CL21B106KOQNNNE	Samsung Electro-Mechanics
C32, C36, C39, C40, C41, C42, C43	7	0.1uF	CAP, CERM, 0.1 uF, 10 V, +/- 10%, X7R, 0603	0603	0603ZC104KAT2A	AVX
D5, D6, D7, D8, D9, D10, D11, D12, D13, D14, D15, D16	12	Green	LED, Green, SMD	LED_0805	APT2012LZGCK	Kingbright
H1	1		Magnet Neodymium Iron Boron (NdFeB) N35 0.187" Dia x 1.000" H (4.76mm x 25.4mm)		8182	Radial Magnet, Inc.
H2	1		USB 1.1 Cable A Female to A Male 5.90' (1.80m) Shielded		AK669-18	Assmann WSW Components
H9, H10, H11, H12	4		Bumpon, Hemisphere, 0.44 X 0.20, Clear	Transparent Bumpon	SJ-5303 (CLEAR)	3M
J1	1		Header, 100mil, 5x1, Gold, TH	Header, 100mil, 5x1, TH	HTSW-105-07-G-S	Samtec
J2	1		Connector, Plug, USB Type A, R/A, Top Mount SMT	USB Type A right angle	48037-1000	Molex
K1	1		Switch, Slide, SP3T, On-On-On, 3 Pos, 0.3A, 30 VDC, TH	12.6x4.3mm	SS-13D16-VG 4 PA	C&K Components
M1	1		16 MHz Ultra-Low-Power Microcontroller with 16 KB FRAM, 2 KB SRAM, 60 IO, 10 ch ADC10, LCD, IR Logic, DGG0056A (TSSOP-56)	DGG0056A	MSP430FR4133IG56R	Texas Instruments
R1	1	47k	RES, 47 k, 5%, 0.1 W, 0603	0603	RC0603JR-0747KL	Yageo America
R2, R19	2	0	RES, 0, 5%, 0.1 W, 0603	0603	ERJ-3GEY0R00V	Panasonic
R3, R4, R5, R6, R7, R8, R9, R10, R11, R12, R13, R14, R51	13	100	RES, 100, 1%, 0.1 W, AEC-Q200 Grade 0, 0603	0603	ERJ-3EKF1000V	Panasonic
R16, R20, R21, R22, R23, R24, R25, R26, R27, R28, R29, R30, R31, R32, R33, R34, R47, R48, R49, R52, R53, R54, R55	23	10.0k	RES, 10.0 k, 0.1%, 0.1 W, 0603	0603	RG1608P-103-B-T5	Susumu Co Ltd
R35, R36, R37, R38, R39, R40, R41, R42, R43, R44, R45, R46	12	100k	RES, 100 k, 5%, 0.1 W, AEC-Q200 Grade 0, 0603	0603	ERJ-3GEYJ104V	Panasonic
R50	1	0.5	RES, 0.5, 1%, 0.125 W, 0603	0603	CSR0603FKR500	Susumu Co Ltd

Table 4. Bill of Materials (continued)

Designator	Quantity	Value	Description	Package Reference	Part Number	Manufacturer
TP1	1		Test Point, Compact, Black, TH		5006	Keystone
TP2,TP3, TP4, TP5, TP6, TP7, TP8, TP9, TP10, TP11, TP12, TP13, TP14, TP15, TP16	15		Test Point, Compact, Black, SMT		5015	Keystone
U1	1		Automotive PWM-Output Linear Hall Effect Sensor, LPG0003A (TO-92-3)	LPG0003A	PDRV5057A4ELPGQ1	Texas Instruments
U2	1		Automotive PWM-Output Linear Hall Effect Sensor, LPG0003A (TO-92-3)	LPG0003A	PDRV5057A3ELPGQ1	Texas Instruments
U3	1		Automotive PWM-Output Linear Hall Effect Sensor, LPG0003A (TO-92-3)	LPG0003A	PDRV5057A2ELPGQ1	Texas Instruments
U4	1		Automotive PWM-Output Linear Hall Effect Sensor, LPG0003A (TO-92-3)	LPG0003A	PDRV5057A1ELPGQ1	Texas Instruments
U5	1		Automotive PWM-Output Linear Hall Effect Sensor, LPG0003A (TO-92-3)	LPG0003A	PDRV5056A4ELPGQ1	Texas Instruments
U6	1		Automotive PWM-Output Linear Hall Effect Sensor, LPG0003A (TO-92-3)	LPG0003A	PDRV5056A3ELPGQ1	Texas Instruments
U7	1		Automotive PWM-Output Linear Hall Effect Sensor, LPG0003A (TO-92-3)	LPG0003A	PDRV5056A2ELPGQ1	Texas Instruments
U8	1		Automotive PWM-Output Linear Hall Effect Sensor, LPG0003A (TO-92-3)	LPG0003A	PDRV5056A1ELPGQ1	Texas Instruments
U9	1		Automotive Ratiometric Linear Hall Effect Sensor, LPG0003A (TO-92-3)	LPG0003A	PDRV5055A4ELPGQ1	Texas Instruments
U10	1		Automotive Ratiometric Linear Hall Effect Sensor, LPG0003A (TO-92-3)	LPG0003A	PDRV5055A3ELPGQ1	Texas Instruments
U11	1		Automotive Unipolar Ratiometric Linear Hall Effect Sensor, LPG0003A (TO-92-3)	LPG0003A	PDRV5055A2ELPGQ1	Texas Instruments
U12	1		Automotive Ratiometric Linear Hall Effect Sensor, LPG0003A (TO-92-3)	LPG0003A	PDRV5055A1ELPGQ1	Texas Instruments
U14	1		Single Schmitt-Trigger Buffer, DCK0005A, SMALL T&R	DCK0005A	SN74LVC1G17DCKT	Texas Instruments
U16	1		250-mA Ultra-Low-Noise, Low-IQ LDO, DBV0005A (SOT-23-5)	DBV0005A	LP5907MFX-3.3/NOPB	Texas Instruments
U17	1		Remote 16-Bit I2C and SMBus, Low-Power I/O Expander with Interrupt Output and Config Register, 1.65 to 5.5 V, -40 to 85 degC, 24-pin TSSOP (PW), Green (RoHS & no Sb/Br)	PW0024A	TCA9535PWR	Texas Instruments
U19	1		LCD 7-Segment, TH	50.8x22.86mm	VI-401-DP-RC-S	Varitronix
U20	1		High Speed CMOS Logic Dual 4-Input Multiplexers, D0016A, LARGE T&R	D0016A	CD74HC153M96	Texas Instruments

Table 4. Bill of Materials (continued)

Designator	Quantity	Value	Description	Package Reference	Part Number	Manufacturer
U21	1		1-Ohm 5-V/3.3-V 2-Channel SPDT Switch, DGS0010A (VSSOP-10)	DGS0010A	TS5A23159DGSR	Texas Instruments
S1	1		Switch, Tactile, SPST-NO, 0.02A, 15V, TH	6.0x5.0x6mm	EVQ-21405R	Panasonic

STANDARD TERMS FOR EVALUATION MODULES

1. *Delivery:* TI delivers TI evaluation boards, kits, or modules, including any accompanying demonstration software, components, and/or documentation which may be provided together or separately (collectively, an "EVM" or "EVMs") to the User ("User") in accordance with the terms set forth herein. User's acceptance of the EVM is expressly subject to the following terms.
 - 1.1 EVMs are intended solely for product or software developers for use in a research and development setting to facilitate feasibility evaluation, experimentation, or scientific analysis of TI semiconductors products. EVMs have no direct function and are not finished products. EVMs shall not be directly or indirectly assembled as a part or subassembly in any finished product. For clarification, any software or software tools provided with the EVM ("Software") shall not be subject to the terms and conditions set forth herein but rather shall be subject to the applicable terms that accompany such Software
 - 1.2 EVMs are not intended for consumer or household use. EVMs may not be sold, sublicensed, leased, rented, loaned, assigned, or otherwise distributed for commercial purposes by Users, in whole or in part, or used in any finished product or production system.
2. *Limited Warranty and Related Remedies/Disclaimers:*
 - 2.1 These terms do not apply to Software. The warranty, if any, for Software is covered in the applicable Software License Agreement.
 - 2.2 TI warrants that the TI EVM will conform to TI's published specifications for ninety (90) days after the date TI delivers such EVM to User. Notwithstanding the foregoing, TI shall not be liable for a nonconforming EVM if (a) the nonconformity was caused by neglect, misuse or mistreatment by an entity other than TI, including improper installation or testing, or for any EVMs that have been altered or modified in any way by an entity other than TI, (b) the nonconformity resulted from User's design, specifications or instructions for such EVMs or improper system design, or (c) User has not paid on time. Testing and other quality control techniques are used to the extent TI deems necessary. TI does not test all parameters of each EVM. User's claims against TI under this Section 2 are void if User fails to notify TI of any apparent defects in the EVMs within ten (10) business days after delivery, or of any hidden defects with ten (10) business days after the defect has been detected.
 - 2.3 TI's sole liability shall be at its option to repair or replace EVMs that fail to conform to the warranty set forth above, or credit User's account for such EVM. TI's liability under this warranty shall be limited to EVMs that are returned during the warranty period to the address designated by TI and that are determined by TI not to conform to such warranty. If TI elects to repair or replace such EVM, TI shall have a reasonable time to repair such EVM or provide replacements. Repaired EVMs shall be warranted for the remainder of the original warranty period. Replaced EVMs shall be warranted for a new full ninety (90) day warranty period.

WARNING

Evaluation Kits are intended solely for use by technically qualified, professional electronics experts who are familiar with the dangers and application risks associated with handling electrical mechanical components, systems, and subsystems.

User shall operate the Evaluation Kit within TI's recommended guidelines and any applicable legal or environmental requirements as well as reasonable and customary safeguards. Failure to set up and/or operate the Evaluation Kit within TI's recommended guidelines may result in personal injury or death or property damage. Proper set up entails following TI's instructions for electrical ratings of interface circuits such as input, output and electrical loads.

NOTE:

EXPOSURE TO ELECTROSTATIC DISCHARGE (ESD) MAY CAUSE DEGRADATION OR FAILURE OF THE EVALUATION KIT; TI RECOMMENDS STORAGE OF THE EVALUATION KIT IN A PROTECTIVE ESD BAG.

3 Regulatory Notices:

3.1 United States

3.1.1 Notice applicable to EVMs not FCC-Approved:

FCC NOTICE: This kit is designed to allow product developers to evaluate electronic components, circuitry, or software associated with the kit to determine whether to incorporate such items in a finished product and software developers to write software applications for use with the end product. This kit is not a finished product and when assembled may not be resold or otherwise marketed unless all required FCC equipment authorizations are first obtained. Operation is subject to the condition that this product not cause harmful interference to licensed radio stations and that this product accept harmful interference. Unless the assembled kit is designed to operate under part 15, part 18 or part 95 of this chapter, the operator of the kit must operate under the authority of an FCC license holder or must secure an experimental authorization under part 5 of this chapter.

3.1.2 For EVMs annotated as FCC – FEDERAL COMMUNICATIONS COMMISSION Part 15 Compliant:

CAUTION

This device complies with part 15 of the FCC Rules. Operation is subject to the following two conditions: (1) This device may not cause harmful interference, and (2) this device must accept any interference received, including interference that may cause undesired operation.

Changes or modifications not expressly approved by the party responsible for compliance could void the user's authority to operate the equipment.

FCC Interference Statement for Class A EVM devices

NOTE: This equipment has been tested and found to comply with the limits for a Class A digital device, pursuant to part 15 of the FCC Rules. These limits are designed to provide reasonable protection against harmful interference when the equipment is operated in a commercial environment. This equipment generates, uses, and can radiate radio frequency energy and, if not installed and used in accordance with the instruction manual, may cause harmful interference to radio communications. Operation of this equipment in a residential area is likely to cause harmful interference in which case the user will be required to correct the interference at his own expense.

FCC Interference Statement for Class B EVM devices

NOTE: This equipment has been tested and found to comply with the limits for a Class B digital device, pursuant to part 15 of the FCC Rules. These limits are designed to provide reasonable protection against harmful interference in a residential installation. This equipment generates, uses and can radiate radio frequency energy and, if not installed and used in accordance with the instructions, may cause harmful interference to radio communications. However, there is no guarantee that interference will not occur in a particular installation. If this equipment does cause harmful interference to radio or television reception, which can be determined by turning the equipment off and on, the user is encouraged to try to correct the interference by one or more of the following measures:

- Reorient or relocate the receiving antenna.
- Increase the separation between the equipment and receiver.
- Connect the equipment into an outlet on a circuit different from that to which the receiver is connected.
- Consult the dealer or an experienced radio/TV technician for help.

3.2 Canada

3.2.1 For EVMs issued with an Industry Canada Certificate of Conformance to RSS-210 or RSS-247

Concerning EVMs Including Radio Transmitters:

This device complies with Industry Canada license-exempt RSSs. Operation is subject to the following two conditions:

(1) this device may not cause interference, and (2) this device must accept any interference, including interference that may cause undesired operation of the device.

Concernant les EVMs avec appareils radio:

Le présent appareil est conforme aux CNR d'Industrie Canada applicables aux appareils radio exempts de licence. L'exploitation est autorisée aux deux conditions suivantes: (1) l'appareil ne doit pas produire de brouillage, et (2) l'utilisateur de l'appareil doit accepter tout brouillage radioélectrique subi, même si le brouillage est susceptible d'en compromettre le fonctionnement.

Concerning EVMs Including Detachable Antennas:

Under Industry Canada regulations, this radio transmitter may only operate using an antenna of a type and maximum (or lesser) gain approved for the transmitter by Industry Canada. To reduce potential radio interference to other users, the antenna type and its gain should be so chosen that the equivalent isotropically radiated power (e.i.r.p.) is not more than that necessary for successful communication. This radio transmitter has been approved by Industry Canada to operate with the antenna types listed in the user guide with the maximum permissible gain and required antenna impedance for each antenna type indicated. Antenna types not included in this list, having a gain greater than the maximum gain indicated for that type, are strictly prohibited for use with this device.

Concernant les EVMs avec antennes détachables

Conformément à la réglementation d'Industrie Canada, le présent émetteur radio peut fonctionner avec une antenne d'un type et d'un gain maximal (ou inférieur) approuvé pour l'émetteur par Industrie Canada. Dans le but de réduire les risques de brouillage radioélectrique à l'intention des autres utilisateurs, il faut choisir le type d'antenne et son gain de sorte que la puissance isotrope rayonnée équivalente (p.i.r.e.) ne dépasse pas l'intensité nécessaire à l'établissement d'une communication satisfaisante. Le présent émetteur radio a été approuvé par Industrie Canada pour fonctionner avec les types d'antenne énumérés dans le manuel d'usage et ayant un gain admissible maximal et l'impédance requise pour chaque type d'antenne. Les types d'antenne non inclus dans cette liste, ou dont le gain est supérieur au gain maximal indiqué, sont strictement interdits pour l'exploitation de l'émetteur.

3.3 Japan

3.3.1 *Notice for EVMs delivered in Japan:* Please see http://www.tij.co.jp/lstds/ti_ja/general/eStore/notice_01.page 日本国内に輸入される評価用キット、ボードについては、次のところをご覧ください。
http://www.tij.co.jp/lstds/ti_ja/general/eStore/notice_01.page

3.3.2 *Notice for Users of EVMs Considered "Radio Frequency Products" in Japan:* EVMs entering Japan may not be certified by TI as conforming to Technical Regulations of Radio Law of Japan.

If User uses EVMs in Japan, not certified to Technical Regulations of Radio Law of Japan, User is required to follow the instructions set forth by Radio Law of Japan, which includes, but is not limited to, the instructions below with respect to EVMs (which for the avoidance of doubt are stated strictly for convenience and should be verified by User):

1. Use EVMs in a shielded room or any other test facility as defined in the notification #173 issued by Ministry of Internal Affairs and Communications on March 28, 2006, based on Sub-section 1.1 of Article 6 of the Ministry's Rule for Enforcement of Radio Law of Japan,
2. Use EVMs only after User obtains the license of Test Radio Station as provided in Radio Law of Japan with respect to EVMs, or
3. Use of EVMs only after User obtains the Technical Regulations Conformity Certification as provided in Radio Law of Japan with respect to EVMs. Also, do not transfer EVMs, unless User gives the same notice above to the transferee. Please note that if User does not follow the instructions above, User will be subject to penalties of Radio Law of Japan.

【無線電波を送信する製品の開発キットをお使いになる際の注意事項】 開発キットの中には技術基準適合証明を受けていないものがあります。技術適合証明を受けていないものご使用に際しては、電波法遵守のため、以下のいずれかの措置を取っていただく必要がありますのでご注意ください。

1. 電波法施行規則第6条第1項第1号に基づく平成18年3月28日総務省告示第173号で定められた電波暗室等の試験設備でご使用いただく。
2. 実験局の免許を取得後ご使用いただく。
3. 技術基準適合証明を取得後ご使用いただく。

なお、本製品は、上記の「ご使用にあたっての注意」を譲渡先、移転先に通知しない限り、譲渡、移転できないものとします。

上記を遵守頂けない場合は、電波法の罰則が適用される可能性があることをご留意ください。日本テキサス・インスツルメンツ株式会社
東京都新宿区西新宿 6 丁目 2 4 番 1 号
西新宿三井ビル

3.3.3 *Notice for EVMs for Power Line Communication:* Please see http://www.tij.co.jp/lstds/ti_ja/general/eStore/notice_02.page
電力線搬送波通信についての開発キットをお使いになる際の注意事項については、次のところをご覧ください。http://www.tij.co.jp/lstds/ti_ja/general/eStore/notice_02.page

3.4 European Union

3.4.1 *For EVMs subject to EU Directive 2014/30/EU (Electromagnetic Compatibility Directive):*

This is a class A product intended for use in environments other than domestic environments that are connected to a low-voltage power-supply network that supplies buildings used for domestic purposes. In a domestic environment this product may cause radio interference in which case the user may be required to take adequate measures.

4 *EVM Use Restrictions and Warnings:*

4.1 EVMS ARE NOT FOR USE IN FUNCTIONAL SAFETY AND/OR SAFETY CRITICAL EVALUATIONS, INCLUDING BUT NOT LIMITED TO EVALUATIONS OF LIFE SUPPORT APPLICATIONS.

4.2 User must read and apply the user guide and other available documentation provided by TI regarding the EVM prior to handling or using the EVM, including without limitation any warning or restriction notices. The notices contain important safety information related to, for example, temperatures and voltages.

4.3 *Safety-Related Warnings and Restrictions:*

4.3.1 User shall operate the EVM within TI's recommended specifications and environmental considerations stated in the user guide, other available documentation provided by TI, and any other applicable requirements and employ reasonable and customary safeguards. Exceeding the specified performance ratings and specifications (including but not limited to input and output voltage, current, power, and environmental ranges) for the EVM may cause personal injury or death, or property damage. If there are questions concerning performance ratings and specifications, User should contact a TI field representative prior to connecting interface electronics including input power and intended loads. Any loads applied outside of the specified output range may also result in unintended and/or inaccurate operation and/or possible permanent damage to the EVM and/or interface electronics. Please consult the EVM user guide prior to connecting any load to the EVM output. If there is uncertainty as to the load specification, please contact a TI field representative. During normal operation, even with the inputs and outputs kept within the specified allowable ranges, some circuit components may have elevated case temperatures. These components include but are not limited to linear regulators, switching transistors, pass transistors, current sense resistors, and heat sinks, which can be identified using the information in the associated documentation. When working with the EVM, please be aware that the EVM may become very warm.

4.3.2 EVMs are intended solely for use by technically qualified, professional electronics experts who are familiar with the dangers and application risks associated with handling electrical mechanical components, systems, and subsystems. User assumes all responsibility and liability for proper and safe handling and use of the EVM by User or its employees, affiliates, contractors or designees. User assumes all responsibility and liability to ensure that any interfaces (electronic and/or mechanical) between the EVM and any human body are designed with suitable isolation and means to safely limit accessible leakage currents to minimize the risk of electrical shock hazard. User assumes all responsibility and liability for any improper or unsafe handling or use of the EVM by User or its employees, affiliates, contractors or designees.

4.4 User assumes all responsibility and liability to determine whether the EVM is subject to any applicable international, federal, state, or local laws and regulations related to User's handling and use of the EVM and, if applicable, User assumes all responsibility and liability for compliance in all respects with such laws and regulations. User assumes all responsibility and liability for proper disposal and recycling of the EVM consistent with all applicable international, federal, state, and local requirements.

5. *Accuracy of Information:* To the extent TI provides information on the availability and function of EVMs, TI attempts to be as accurate as possible. However, TI does not warrant the accuracy of EVM descriptions, EVM availability or other information on its websites as accurate, complete, reliable, current, or error-free.

6. *Disclaimers:*

6.1 EXCEPT AS SET FORTH ABOVE, EVMS AND ANY MATERIALS PROVIDED WITH THE EVM (INCLUDING, BUT NOT LIMITED TO, REFERENCE DESIGNS AND THE DESIGN OF THE EVM ITSELF) ARE PROVIDED "AS IS" AND "WITH ALL FAULTS." TI DISCLAIMS ALL OTHER WARRANTIES, EXPRESS OR IMPLIED, REGARDING SUCH ITEMS, INCLUDING BUT NOT LIMITED TO ANY EPIDEMIC FAILURE WARRANTY OR IMPLIED WARRANTIES OF MERCHANTABILITY OR FITNESS FOR A PARTICULAR PURPOSE OR NON-INFRINGEMENT OF ANY THIRD PARTY PATENTS, COPYRIGHTS, TRADE SECRETS OR OTHER INTELLECTUAL PROPERTY RIGHTS.

6.2 EXCEPT FOR THE LIMITED RIGHT TO USE THE EVM SET FORTH HEREIN, NOTHING IN THESE TERMS SHALL BE CONSTRUED AS GRANTING OR CONFERRING ANY RIGHTS BY LICENSE, PATENT, OR ANY OTHER INDUSTRIAL OR INTELLECTUAL PROPERTY RIGHT OF TI, ITS SUPPLIERS/LICENSORS OR ANY OTHER THIRD PARTY, TO USE THE EVM IN ANY FINISHED END-USER OR READY-TO-USE FINAL PRODUCT, OR FOR ANY INVENTION, DISCOVERY OR IMPROVEMENT, REGARDLESS OF WHEN MADE, CONCEIVED OR ACQUIRED.

7. *USER'S INDEMNITY OBLIGATIONS AND REPRESENTATIONS.* USER WILL DEFEND, INDEMNIFY AND HOLD TI, ITS LICENSORS AND THEIR REPRESENTATIVES HARMLESS FROM AND AGAINST ANY AND ALL CLAIMS, DAMAGES, LOSSES, EXPENSES, COSTS AND LIABILITIES (COLLECTIVELY, "CLAIMS") ARISING OUT OF OR IN CONNECTION WITH ANY HANDLING OR USE OF THE EVM THAT IS NOT IN ACCORDANCE WITH THESE TERMS. THIS OBLIGATION SHALL APPLY WHETHER CLAIMS ARISE UNDER STATUTE, REGULATION, OR THE LAW OF TORT, CONTRACT OR ANY OTHER LEGAL THEORY, AND EVEN IF THE EVM FAILS TO PERFORM AS DESCRIBED OR EXPECTED.

8. *Limitations on Damages and Liability:*

8.1 *General Limitations.* IN NO EVENT SHALL TI BE LIABLE FOR ANY SPECIAL, COLLATERAL, INDIRECT, PUNITIVE, INCIDENTAL, CONSEQUENTIAL, OR EXEMPLARY DAMAGES IN CONNECTION WITH OR ARISING OUT OF THESE TERMS OR THE USE OF THE EVMS , REGARDLESS OF WHETHER TI HAS BEEN ADVISED OF THE POSSIBILITY OF SUCH DAMAGES. EXCLUDED DAMAGES INCLUDE, BUT ARE NOT LIMITED TO, COST OF REMOVAL OR REINSTALLATION, ANCILLARY COSTS TO THE PROCUREMENT OF SUBSTITUTE GOODS OR SERVICES, RETESTING, OUTSIDE COMPUTER TIME, LABOR COSTS, LOSS OF GOODWILL, LOSS OF PROFITS, LOSS OF SAVINGS, LOSS OF USE, LOSS OF DATA, OR BUSINESS INTERRUPTION. NO CLAIM, SUIT OR ACTION SHALL BE BROUGHT AGAINST TI MORE THAN TWELVE (12) MONTHS AFTER THE EVENT THAT GAVE RISE TO THE CAUSE OF ACTION HAS OCCURRED.

8.2 *Specific Limitations.* IN NO EVENT SHALL TI'S AGGREGATE LIABILITY FROM ANY USE OF AN EVM PROVIDED HEREUNDER, INCLUDING FROM ANY WARRANTY, INDEMNITY OR OTHER OBLIGATION ARISING OUT OF OR IN CONNECTION WITH THESE TERMS, , EXCEED THE TOTAL AMOUNT PAID TO TI BY USER FOR THE PARTICULAR EVM(S) AT ISSUE DURING THE PRIOR TWELVE (12) MONTHS WITH RESPECT TO WHICH LOSSES OR DAMAGES ARE CLAIMED. THE EXISTENCE OF MORE THAN ONE CLAIM SHALL NOT ENLARGE OR EXTEND THIS LIMIT.

9. *Return Policy.* Except as otherwise provided, TI does not offer any refunds, returns, or exchanges. Furthermore, no return of EVM(s) will be accepted if the package has been opened and no return of the EVM(s) will be accepted if they are damaged or otherwise not in a resalable condition. If User feels it has been incorrectly charged for the EVM(s) it ordered or that delivery violates the applicable order, User should contact TI. All refunds will be made in full within thirty (30) working days from the return of the components(s), excluding any postage or packaging costs.

10. *Governing Law:* These terms and conditions shall be governed by and interpreted in accordance with the laws of the State of Texas, without reference to conflict-of-laws principles. User agrees that non-exclusive jurisdiction for any dispute arising out of or relating to these terms and conditions lies within courts located in the State of Texas and consents to venue in Dallas County, Texas. Notwithstanding the foregoing, any judgment may be enforced in any United States or foreign court, and TI may seek injunctive relief in any United States or foreign court.

Mailing Address: Texas Instruments, Post Office Box 655303, Dallas, Texas 75265
Copyright © 2019, Texas Instruments Incorporated

IMPORTANT NOTICE AND DISCLAIMER

TI PROVIDES TECHNICAL AND RELIABILITY DATA (INCLUDING DATASHEETS), DESIGN RESOURCES (INCLUDING REFERENCE DESIGNS), APPLICATION OR OTHER DESIGN ADVICE, WEB TOOLS, SAFETY INFORMATION, AND OTHER RESOURCES "AS IS" AND WITH ALL FAULTS, AND DISCLAIMS ALL WARRANTIES, EXPRESS AND IMPLIED, INCLUDING WITHOUT LIMITATION ANY IMPLIED WARRANTIES OF MERCHANTABILITY, FITNESS FOR A PARTICULAR PURPOSE OR NON-INFRINGEMENT OF THIRD PARTY INTELLECTUAL PROPERTY RIGHTS.

These resources are intended for skilled developers designing with TI products. You are solely responsible for (1) selecting the appropriate TI products for your application, (2) designing, validating and testing your application, and (3) ensuring your application meets applicable standards, and any other safety, security, or other requirements. These resources are subject to change without notice. TI grants you permission to use these resources only for development of an application that uses the TI products described in the resource. Other reproduction and display of these resources is prohibited. No license is granted to any other TI intellectual property right or to any third party intellectual property right. TI disclaims responsibility for, and you will fully indemnify TI and its representatives against, any claims, damages, costs, losses, and liabilities arising out of your use of these resources.

TI's products are provided subject to TI's Terms of Sale (www.ti.com/legal/termsofsale.html) or other applicable terms available either on ti.com or provided in conjunction with such TI products. TI's provision of these resources does not expand or otherwise alter TI's applicable warranties or warranty disclaimers for TI products.

Mailing Address: Texas Instruments, Post Office Box 655303, Dallas, Texas 75265
Copyright © 2019, Texas Instruments Incorporated