

THIS DRAWING CONTAINS INFORMATION PROPRIETARY TO RF INDUSTRIES.  
 ANY UNAUTHORIZED USE OF THIS DRAWING IS EXPRESSLY PROHIBITED  
 WITHOUT WRITTEN PERMISSION FROM RF INDUSTRIES.  
 ANY VIOLATION IS PUNISHABLE UNDER U.S. COPYRIGHT LAWS.

ALL DIMENSIONS ARE REFERENCE ONLY

PART NO.

**RFB-1100-2**

REV	DESCRIPTION	DWN	DATE	APPROVED
A	UPDATE CONNECTOR CONFIGURATION	JDM	4/22/08	R. RICE

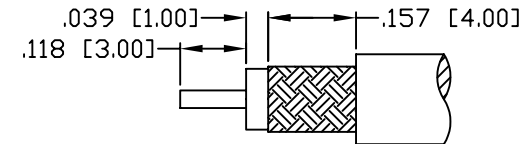
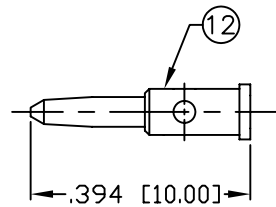
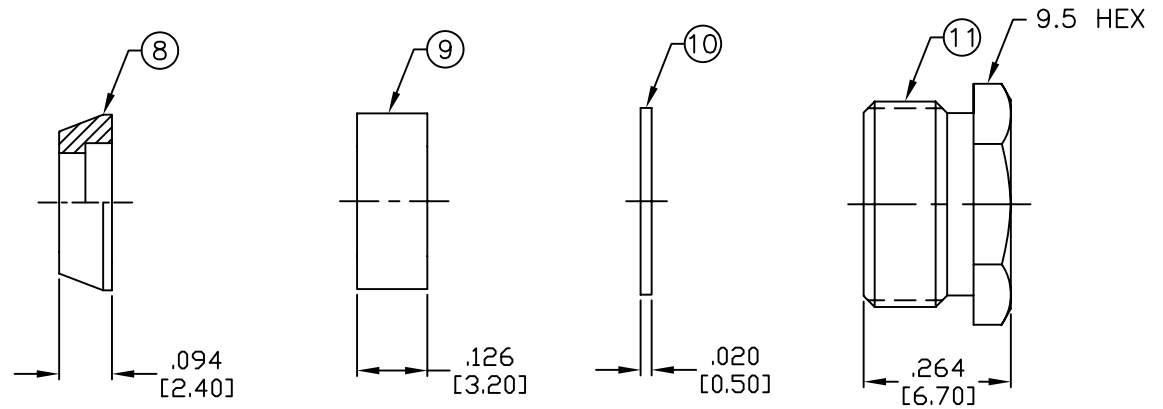
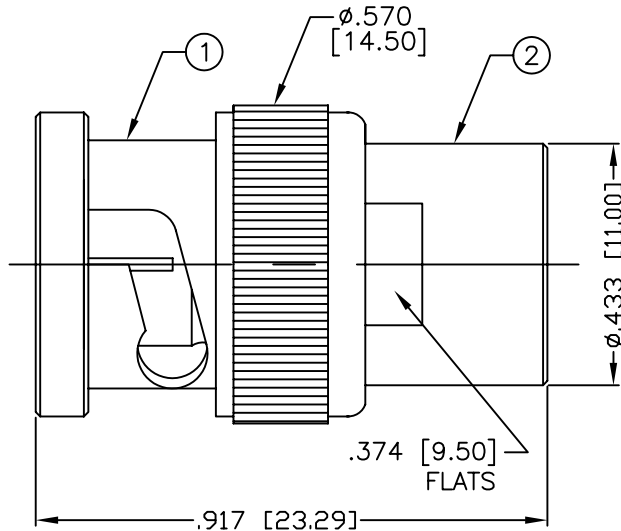

**SPECIFICATIONS:**

IMPEDANCE: 50 Ohms  
 FREQUENCY RANGE: 0-4 GHz  
 VSWR: 1.3 Max.  
 WORKING VOLTAGE: 500 V rms @ sea level  
 TEMPERATURE RANGE: -65°C TO 85°C  
 INSULATION RESISTANCE: 5k M Ohms min.  
 FOR RG-58, 58A, 58C, 141, 141A, BELDEN 8240,  
 8262, 9201, 9203, 9310, 9311 & COMM/SCOPE 0268

RECOMMENDED CRIMP DIE: .068

RECOMMENDED STRIPPING DIM'S

1	SHELL	1	BRASS	NICKEL, 80 $\mu$ "	008974	
2	BODY	1	BRASS	NICKEL, 80 $\mu$ "		
3	INSULATOR	1	DELFIN	---		
4	GASKET	1	SILICONE	RED		
5	RETAINER RING	1	BRASS	NICKEL, 100 $\mu$ "		
6	SPRING	1	SK5	NICKEL, 200 $\mu$ "		
7	WASHER	1	BRASS	NICKEL, 80 $\mu$ "		
8	CLAMP	1	BRASS	NICKEL, 80 $\mu$ "		
9	GASKET	1	SILICONE	RED		
10	WASHER	1	BRASS	NICKEL, 80 $\mu$ "		
11	BACK NUT	1	BRASS	NICKEL, 80 $\mu$ "		
12	PIN	1	BRASS	GOLD, 3 $\mu$ "		
13						
14						
#	DESCRIPTION	QTY	MATRL	FINISH	APPROVALS	DATE

UNLESS OTHERWISE SPECIFIED:  
 1. REMOVE ALL BURRS  
 2. BREAK ALL CORNERS & EDGES .005 R. MAX.  
 3. CHAMFER 1ST & LAST THREADS 45°  
 4. SURFACE ROUGHNESS 63 FINISH MIL-STD-10  
 5. DIAMETERS ON COMMON CENTERS TO BE CONCENTRIC WITHIN .002 T.I.R.  
 6. ALL DIMENSIONS ARE AFTER PLATING.

DIMENSIONS ARE IN INCHES AND [MILLIMETERS]  
 UNLESS OTHERWISE NOTED TOLERANCES ARE:  
 DECIMALS .xxx±.003 [.08]  
 DIAMETER .xxx±.001 [.03]  
 .xx±.005 [.13]

**RFconnectors**  
 DIVISION OF RF INDUSTRIES, LTD.

7610 MIRAMAR RD  
 SAN DIEGO, CA 92126  
 (858) 549-6340  
 (858) 549-6345 FAX

**BNC PLUG, CLAMP**

SIZE	CABLE GROUP	DWG NO.	REV
A	C	RFB-1100-2	A
SCALE:	NTS	CAD FILE	OUTLINE
SHEET			1 OF 1