

## ISL62882, ISL62882B

Multiphase PWM Regulator for IMVP-6.5™ Mobile CPUs and GPUs

FN6890  
Rev 4.00  
June 21, 2011

The ISL62882 is a multiphase PWM buck regulator for microprocessor or graphics processor core power supply. The multiphase buck converter uses interleaved phases to reduce the total output voltage ripple with each phase carrying a portion of the total load current, providing better system performance, superior thermal management, lower component cost, reduced power dissipation, and smaller implementation area. The ISL62882 uses two integrated gate drivers to provide a complete solution. The PWM modulator is based on Intersil's Robust Ripple Regulator (R<sup>3</sup>) technology™. Compared with traditional modulators, the R<sup>3</sup>™ modulator commands variable switching frequency during load transients, achieving faster transient response. With the same modulator, the switching frequency is reduced at light load, increasing the regulator efficiency.

The ISL62882 can be configured as CPU or graphics Vcore controller and is fully compliant with IMVP-6.5™ specifications. It responds to PSI# and DPRSLPVR signals by adding or dropping Phase 2, adjusting overcurrent protection threshold accordingly, and entering/exiting diode emulation mode. It reports the regulator output current through the IMON pin. It senses the current by using either discrete resistor or inductor DCR whose variation over temperature can be thermally compensated by a single NTC thermistor. It uses differential remote voltage sensing to accurately regulate the processor die voltage. The unique split LGATE function further increases light load efficiency. The adaptive body diode conduction time reduction function minimizes the body diode conduction loss in diode emulation mode. User-selectable overshoot reduction function offers an option to aggressively reduce the output capacitors as well as the option to disable it for users concerned about increased system thermal stress. The ISL62882 offers the FB2 function to optimize 1-phase performance.

The ISL62882B has the same functions as the ISL62882, but comes in a different package.

## Features

- Programmable 1- or 2-Phase CPU Mode Operation or 1-Phase GPU Mode Operation
- Precision Multiphase Core Voltage Regulation
  - 0.5% System Accuracy Over-Temperature
  - Enhanced Load Line Accuracy
- Microprocessor Voltage Identification Input
  - 7-Bit VID Input, 0V to 1.500V in 12.5mV Steps
  - Supports VID Changes On-The-Fly
- Supports Multiple Current Sensing Methods
  - Lossless Inductor DCR Current Sensing
  - Precision Resistor Current Sensing
- Supports PSI# and DPRSLPVR modes
- Superior Noise Immunity and Transient Response
- Current Monitor and Thermal Monitor
- Differential Remote Voltage Sensing
- High Efficiency Across Entire Load Range
- Programmable 1- or 2-Phase Operation
- Two Integrated Gate Drivers
- Excellent Dynamic Current Balance Between Phases
- Split LGATE1 Drivers Increases Light Load Efficiency
- FB2 Function Optimizes 1-Phase Mode Performance
- Adaptive Body Diode Conduction Time Reduction
- User-selectable Overshoot Reduction Function
- Small Footprint 40 Ld 5x5 or 48 Ld 6x6 TQFN Packages
- Pb-Free (RoHS Compliant)

## Applications

- Notebook Core Voltage Regulator
- Notebook GPU Voltage Regulator

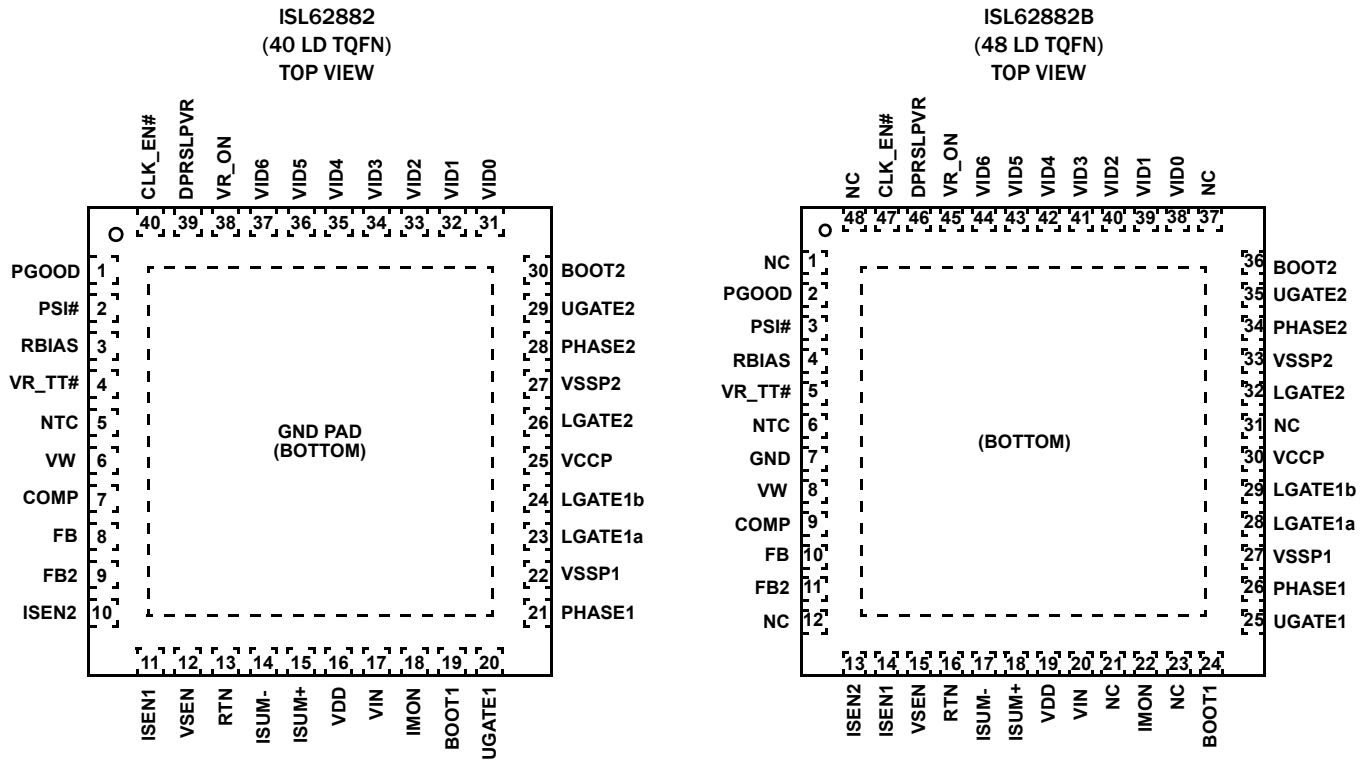
## Ordering Information

PART NUMBER (Notes 1, 2, 3)	PART MARKING	TEMP. RANGE (°C)	PACKAGE (Pb-Free)	PKG. DWG. #
ISL62882IRTZ	62882 IRTZ	-40 to +100	40 Ld 5x5 TQFN	L40.5x5
ISL62882HRTZ	62882 HRTZ	-10 to +100	40 Ld 5x5 TQFN	L40.5x5
ISL62882BHRTZ	62882 BHRTZ	-10 to +100	48 Ld 6x6 TQFN	L48.6x6

### NOTES:

1. Add "-T\*" suffix for tape and reel. Please refer to [TB347](#) for details on reel specifications.
2. These Intersil Pb-free plastic packaged products employ special Pb-free material sets, molding compounds/die attach materials, and 100% matte tin plate plus anneal (e3 termination finish, which is RoHS compliant and compatible with both SnPb and Pb-free soldering operations). Intersil Pb-free products are MSL classified at Pb-free peak reflow temperatures that meet or exceed the Pb-free requirements of IPC/JEDEC J STD-020.
3. For Moisture Sensitivity Level (MSL), please see device information page for [ISL62882](#), [ISL62882B](#). For more information on MSL please see techbrief [TB363](#).

## Pin Configurations



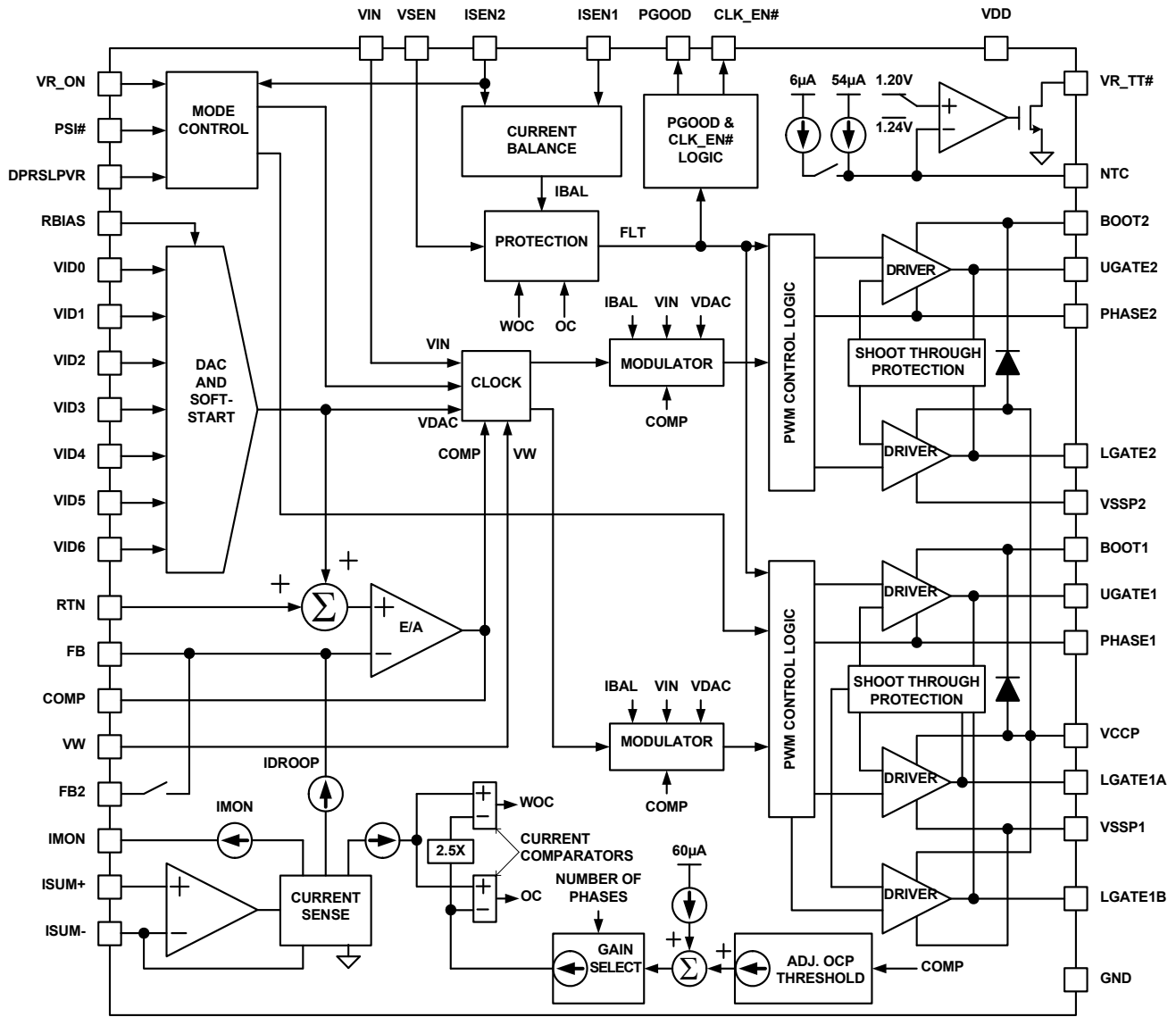
## Functional Pin Descriptions

ISL62882	ISL62882B	SYMBOL	DESCRIPTION
-	7	GND	Signal common of the IC. Unless otherwise stated, signals are referenced to the GND pin.
1	2	PGOOD	Power-Good open-drain output indicating when the regulator is able to supply regulated voltage. Pull-up externally with a 680Ω resistor to VCCP or 1.9kΩ to 3.3V.
2	3	PSI#	Low load current indicator input. When asserted low, indicates a reduced load current condition.
3	4	RBIAS	A resistor to GND sets internal current reference. Use 147kΩ or 47kΩ. The choice of Rbias value, together with the ISEN2 pin configuration and the external resistance from the COMP pin to GND, programs the controller to enable/disable the overshoot reduction function and to select the CPU/GPU mode.
4	5	VR_TT#	Thermal overload output indicator.
5	6	NTC	Thermistor input to VR_TT# circuit.
6	8	VW	A resistor from this pin to COMP programs the switching frequency (8kΩ gives approximately 300kHz).
7	9	COMP	This pin is the output of the error amplifier. Also, a resistor across this pin and GND adjusts the overcurrent threshold.
8	10	FB	This pin is the inverting input of the error amplifier.
9	11	FB2	There is a switch between the FB2 pin and the FB pin. The switch is on in 2-phase mode and is off in 1-phase mode. The components connecting to FB2 are used to adjust the compensation in 1-phase mode to achieve optimum performance.
10	13	ISEN2	Individual current sensing for Phase 2. When ISEN2 is pulled to 5V VDD, the controller will disable Phase 2.
11	14	ISEN1	Individual current sensing for phase 1.
12	15	VSEN	Remote core voltage sense input. Connect to microprocessor die.

## Functional Pin Descriptions (Continued)

ISL62882	ISL62882B	SYMBOL	DESCRIPTION
13	16	RTN	Remote voltage sensing return. Connect to ground at microprocessor die.
14, 15	17, 18	ISUM- and ISUM+	Droop current sense input.
16	19	VDD	5V bias power.
17	20	VIN	Battery supply voltage, used for feed-forward.
18	22	IMON	An analog output. IMON outputs a current proportional to the regulator output current.
19	24	BOOT1	Connect an MLCC capacitor across the BOOT1 and the PHASE1 pins. The boot capacitor is charged through an internal boot diode connected from the VCCP pin to the BOOT1 pin, each time the PHASE1 pin drops below VCCP minus the voltage dropped across the internal boot diode.
20	25	UGATE1	Output of the Phase-1 high-side MOSFET gate driver. Connect the UGATE1 pin to the gate of the Phase-1 high-side MOSFET.
21	26	PHASE1	Current return path for the Phase-1 high-side MOSFET gate driver. Connect the PHASE1 pin to the node consisting of the high-side MOSFET source, the low-side MOSFET drain, and the output inductor of Phase-1.
22	27	VSSP1	Current return path for the Phase-1 low-side MOSFET gate driver. Connect the VSSP1 pin to the source of the Phase-1 low-side MOSFET through a low impedance path, preferably in parallel with the traces connecting the LGATE1a and the LGATE1b pins to the gates of the Phase-1 low-side MOSFETs.
23	28	LGATE1a	Output of the Phase-1 low-side MOSFET gate driver that is always active. Connect the LGATE1a pin to the gate of the Phase-1 low-side MOSFET that is active all the time.
24	29	LGATE1b	Another output of the Phase-1 low-side MOSFET gate driver. This gate driver will be pulled low when the DPRSLPVR pin logic is high. Connect the LGATE1b pin to the gate of the Phase-1 low-side MOSFET that is idle in deeper sleep mode.
-	-	LGATE1	Output of the Phase-1 low-side MOSFET gate driver. Connect the LGATE1 pin to the gate of the Phase-1 low-side MOSFET.
25	30	VCCP	Input voltage bias for the internal gate drivers. Connect +5V to the VCCP pin. Decouple with at least 1 $\mu$ F of an MLCC capacitor to VSSP1 and VSSP2 pins respectively.
26	32	LGATE2	Output of the Phase-2 low-side MOSFET gate driver. Connect the LGATE2 pin to the gate of the Phase-2 low-side MOSFET.
27	33	VSSP2	Current return path for the Phase-2 converter low-side MOSFET gate driver. Connect the VSSP2 pin to the source of the Phase-2 low-side MOSFET through a low impedance path, preferably in parallel with the trace connecting the LGATE2 pin to the gate of the Phase-2 low-side MOSFET.
28	34	PHASE2	Current return path for the Phase-2 high-side MOSFET gate driver. Connect the PHASE2 pin to the node consisting of the high-side MOSFET source, the low-side MOSFET drain, and the output inductor of Phase-2.
29	35	UGATE2	Output of the Phase-2 high-side MOSFET gate driver. Connect the UGATE2 pin to the gate of the Phase-2 high-side MOSFET.
30	36	BOOT2	Connect an MLCC capacitor across the BOOT2 and the PHASE2 pins. The boot capacitor is charged through an internal boot diode connected from the VCCP pin to the BOOT2 pin, each time the PHASE2 pin drops below VCCP minus the voltage dropped across the internal boot diode.
31 thru 37	38 thru 44	VID0 thru VID6	VID input with VID0 = LSB and VID6 = MSB.
38	45	VR_ON	Voltage regulator enable input. A high level logic signal on this pin enables the regulator.
39	46	DPRSLPVR	Deeper sleep enable signal. A high level logic signal on this pin indicates that the microprocessor is in deeper sleep mode.
40	47	CLK_EN#	Open drain output to enable system PLL clock. It goes low 13 switching cycles after Vcore is within 10% of Vboot.
-	48	NC	No connect.
pad	pad	BOTTOM	The bottom pad of ISL62882B is electrically connected to the GND pin inside the IC.

# Block Diagram



## Absolute Maximum Ratings

Supply Voltage, VDD	-0.3V to +7V
Battery Voltage, VIN	+28V
Boot Voltage (BOOT)	-0.3V to +33V
Boot to Phase Voltage (BOOT-PHASE)	-0.3V to +7V(DC)
	-0.3V to +9V(<10ns)
Phase Voltage (PHASE)	-7V (<20ns Pulse Width, 10μJ)
UGATE Voltage (UGATE)	PHASE-0.3V (DC) to BOOT
	PHASE-5V (<20ns Pulse Width, 10μJ) to BOOT
LGATE1a and 1b and LGATE2 Voltage	-0.3V (DC) to VDD+0.3V
LGATE1a and 1b	
	-2.5V (<20ns Pulse Width, 2.5μJ) to VDD+0.3V
LGATE1a and 1b	
	-2.5V (<20ns Pulse Width, 5μJ) to VDD+0.3V
All Other Pins	-0.3V to (VDD +0.3V)
Open Drain Outputs, PGOOD, VR_TT#, CLK_EN#	-0.3V to +7V

## Thermal Information

Thermal Resistance (Typical)	$\theta_{JA}$ (°C/W)	$\theta_{JC}$ (°C/W)
40 Ld TQFN Package (Notes 4, 5)	32	3
48 Ld TQFN Package (Notes 4, 5)	29	2
Maximum Junction Temperature	+150°C	
Maximum Storage Temperature Range	-65°C to +150°C	
Maximum Junction Temperature (Plastic Package)	+150°C	
Storage Temperature Range	-65°C to +150°C	
Pb-Free Reflow Profile	see link below	
	<a href="http://www.intersil.com/pbfree/Pb-FreeReflow.asp">http://www.intersil.com/pbfree/Pb-FreeReflow.asp</a>	

## Recommended Operating Conditions

Supply Voltage, VDD	+5V ±5%
Battery Voltage, VIN	+4.5V to 25V
Ambient Temperature	
ISL62882HRTZ, ISL62882BHRTZ	-10°C to +100°C
ISL62882IRTZ	-40°C to +100°C
Junction Temperature	
ISL62882HRTZ, ISL62882BHRTZ	-10°C to +125°C
ISL62882IRTZ	-40°C to +125°C

**CAUTION:** Do not operate at or near the maximum ratings listed for extended periods of time. Exposure to such conditions may adversely impact product reliability and result in failures not covered by warranty.

### NOTE:

- $\theta_{JA}$  is measured in free air with the component mounted on a high effective thermal conductivity test board with “direct attach” features. See Tech Brief TB379.
- For  $\theta_{JC}$ , the “case temp” location is the center of the exposed metal pad on the package underside.

**Electrical Specifications** Operating Conditions: VDD = 5V, T<sub>A</sub> = -40°C to +100°C, f<sub>SW</sub> = 300kHz, unless otherwise noted. **Boldface limits apply over the operating temperature range, -40°C to +100°C.**

PARAMETER	SYMBOL	TEST CONDITIONS	MIN (Note 6)	TYP	MAX (Note 6)	UNITS
<b>INPUT POWER SUPPLY</b>						
+5V Supply Current	I <sub>VDD</sub>	VR_ON = 3.3V		4	<b>4.6</b>	mA
		VR_ON = 0V			<b>1</b>	μA
Battery Supply Current	I <sub>VIN</sub>	VR_ON = 0V			<b>1</b>	μA
V <sub>IN</sub> Input Resistance	R <sub>VIN</sub>	VR_ON = 3.3V		900		kΩ
Power-On-Reset Threshold	POR <sub>r</sub>	V <sub>DD</sub> rising		4.35	<b>4.5</b>	V
	POR <sub>f</sub>	V <sub>DD</sub> falling	<b>4.00</b>	4.15		V
<b>SYSTEM AND REFERENCES</b>						
System Accuracy	HRTZ %Error (V <sub>CC_CORE</sub> )	No load; closed loop, active mode range VID = 0.75V to 1.50V,	<b>-0.5</b>		<b>+0.5</b>	%
		VID = 0.5V to 0.7375V	<b>-8</b>		<b>+8</b>	mV
		VID = 0.3V to 0.4875V	<b>-15</b>		<b>+15</b>	mV
	IRTZ %Error (V <sub>CC_CORE</sub> )	No load; closed loop, active mode range VID = 0.75V to 1.50V	<b>-0.8</b>		<b>+0.8</b>	%
		VID = 0.5V to 0.7375V	<b>-10</b>		<b>+10</b>	mV
		VID = 0.3V to 0.4875V	<b>-18</b>		<b>+18</b>	mV
V <sub>BOOT</sub>			<b>1.0945</b>	1.100	<b>1.1055</b>	V
Maximum Output Voltage	V <sub>CC_CORE(max)</sub>	VID = [0000000]		1.500		V
Minimum Output Voltage	V <sub>CC_CORE(min)</sub>	VID = [1100000]		0.300		V
R <sub>BIAS</sub> Voltage		R <sub>BIAS</sub> = 147kΩ	<b>1.45</b>	1.47	<b>1.49</b>	V

**Electrical Specifications** Operating Conditions: VDD = 5V, T<sub>A</sub> = -40°C to +100°C, f<sub>SW</sub> = 300kHz, unless otherwise noted.  
**Boldface limits apply over the operating temperature range, -40°C to +100°C. (Continued)**

PARAMETER	SYMBOL	TEST CONDITIONS	MIN (Note 6)	TYP	MAX (Note 6)	UNITS
<b>CHANNEL FREQUENCY</b>						
Nominal Channel Frequency	f <sub>SW(nom)</sub>	R <sub>set</sub> = 7kΩ, 2-channel operation, V <sub>COMP</sub> = 1V	<b>285</b>	300	<b>315</b>	kHz
Adjustment Range			<b>200</b>		<b>500</b>	kHz
<b>AMPLIFIERS</b>						
Current-Sense Amplifier Input Offset		I <sub>FB</sub> = 0A	<b>-0.15</b>		<b>+0.15</b>	mV
Error Amp DC Gain	A <sub>VO</sub>			90		dB
Error Amp Gain-Bandwidth Product	GBW	C <sub>L</sub> = 20pF		18		MHz
<b>ISEN</b>						
Imbalance Voltage		Maximum of ISENs - Minimum of ISENs			<b>1</b>	mV
Input Bias Current				20		nA
<b>POWER-GOOD AND PROTECTION MONITORS</b>						
PGOOD Low Voltage	V <sub>OL</sub>	I <sub>PGOOD</sub> = 4mA		0.26	<b>0.4</b>	V
PGOOD Leakage Current	I <sub>OH</sub>	PGOOD = 3.3V	<b>-1</b>		<b>1</b>	μA
PGOOD Delay	tpgd	CLK_ENABLE# LOW to PGOOD HIGH	<b>6.3</b>	7.6	<b>8.9</b>	ms
<b>GATE DRIVER</b>						
UGATE Pull-Up Resistance	R <sub>UGPU</sub>	200mA Source Current		1.0	<b>1.5</b>	Ω
UGATE Source Current	I <sub>UGSRC</sub>	UGATE - PHASE = 2.5V		2.0		A
UGATE Sink Resistance	R <sub>UGPD</sub>	250mA Sink Current		1.0	<b>1.5</b>	Ω
UGATE Sink Current	I <sub>UGSNK</sub>	UGATE - PHASE = 2.5V		2.0		A
LGATE1a and 1b Pull-Up Resistance	R <sub>LGPU</sub>	250mA Source Current		2.0	<b>3</b>	Ω
LGATE1a and 1b Source Current	I <sub>LGSRC</sub>	LGATE1a and 1b - VSSP1 = 2.5V		1.0		A
LGATE1a and 1b Sink Resistance	R <sub>LGPD</sub>	250mA Sink Current		1	<b>1.8</b>	Ω
LGATE1a and 1b Sink Current	I <sub>LGSNK</sub>	LGATE1a and 1b - VSSP1 = 2.5V		2.0		A
UGATE1 to LGATE1a and 1b Deadtime	t <sub>UGFLGR</sub>	UGATE1 falling to LGATE1a and 1b rising, no load		23		ns
LGATE1a and 1b to UGATE1 Deadtime	t <sub>LGFLGR</sub>	LGATE1a and 1b falling to UGATE1 rising, no load		28		ns
LGATE Pull-Up Resistance	R <sub>LGPU</sub>	250mA Source Current		1.0	<b>1.5</b>	Ω
LGATE Source Current	I <sub>LGSRC</sub>	LGATE - VSSP = 2.5V		2.0		A
LGATE Sink Resistance	R <sub>LGPD</sub>	250mA Sink Current		0.5	<b>0.9</b>	Ω
LGATE Sink Current	I <sub>LGSNK</sub>	LGATE - VSSP = 2.5V		4.0		A
UGATE to LGATE Deadtime	t <sub>UGFLGR</sub>	UGATE falling to LGATE rising, no load		23		ns
LGATE to UGATE Deadtime	t <sub>LGFLGR</sub>	LGATE falling to UGATE rising, no load		28		ns
<b>BOOTSTRAP DIODE</b>						
Forward Voltage	V <sub>F</sub>	PVCC = 5V, I <sub>F</sub> = 2mA		0.58		V
Reverse Leakage	I <sub>R</sub>	V <sub>R</sub> = 25V		0.2		μA
<b>PROTECTION</b>						
Overvoltage Threshold	OV <sub>H</sub>	VSEN rising above setpoint for >1ms	<b>150</b>	195	<b>240</b>	mV
Severe Overvoltage Threshold	OV <sub>HS</sub>	VSEN rising for >2μs	<b>1.525</b>	1.55	<b>1.575</b>	V
OC Threshold Offset at R <sub>comp</sub> = Open Circuit		2-phase configuration, ISUM- pin current	<b>18.3</b>	20.2	<b>22.1</b>	μA
		1-phase configuration, ISUM- pin current	<b>8.2</b>	10.1	<b>12.0</b>	μA
Current Imbalance Threshold		One ISEN above another ISEN for >1.2ms		9		mV
Undervoltage Threshold	UV <sub>f</sub>	VSEN falling below setpoint for >1.2ms	<b>-355</b>	-295	<b>-235</b>	mV

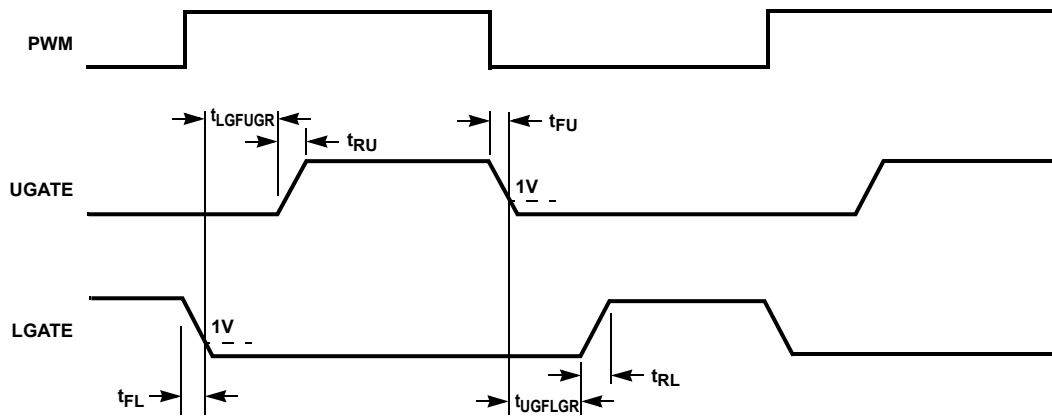
**Electrical Specifications** Operating Conditions: VDD = 5V, TA = -40°C to +100°C, fSW = 300kHz, unless otherwise noted.  
**Boldface limits apply over the operating temperature range, -40°C to +100°C. (Continued)**

PARAMETER	SYMBOL	TEST CONDITIONS	MIN (Note 6)	TYP	MAX (Note 6)	UNITS
<b>LOGIC THRESHOLDS</b>						
VR_ON Input Low	V <sub>IL(1.0V)</sub>				<b>0.3</b>	V
VR_ON Input High	V <sub>IH(1.0V)</sub>	ISL62882HRTZ	<b>0.7</b>			V
	V <sub>IH(1.0V)</sub>	ISL62882IRTZ	<b>0.75</b>			V
VID0-VID6, PSI#, and DPRSLPVR Input Low	V <sub>IL(1.0V)</sub>				<b>0.3</b>	V
VID0-VID6, PSI#, and DPRSLPVR Input High	V <sub>IH(1.0V)</sub>		<b>0.7</b>			V
<b>THERMAL MONITOR</b>						
NTC Source Current		NTC = 1.3V	<b>53</b>	60	<b>67</b>	μA
Over-Temperature Threshold		V (NTC) falling	<b>1.18</b>	1.2	<b>1.22</b>	V
VR_TT# Low Output Resistance	R <sub>TT</sub>	I = 20mA		6.5	<b>9</b>	Ω
<b>CLK_EN# OUTPUT LEVELS</b>						
CLK_EN# Low Output Voltage	V <sub>OL</sub>	I = 4mA		0.26	<b>0.4</b>	V
CLK_EN# Leakage Current	I <sub>OH</sub>	CLK_EN# = 3.3V	<b>-1</b>		<b>1</b>	μA
<b>CURRENT MONITOR</b>						
IMON Output Current	I <sub>IMON</sub>	ISUM- pin current = 20μA	<b>108</b>	120	<b>132</b>	μA
		ISUM- pin current = 10μA	<b>51</b>	60	<b>69</b>	μA
		ISUM- pin current = 5μA	<b>22</b>	30	<b>37.5</b>	μA
IMON Clamp Voltage	V <sub>IMONCLAMP</sub>			1.1	<b>1.15</b>	V
Current Sinking Capability				275		μA
<b>INPUTS</b>						
VR_ON Leakage Current	I <sub>VR_ON</sub>	VR_ON = 0V	<b>-1</b>	0		μA
		VR_ON = 1V		0	<b>1</b>	μA
VIDx Leakage Current	I <sub>VIDx</sub>	VIDx = 0V	<b>-1</b>	0		μA
		VIDx = 1V		0.45	<b>1</b>	μA
PSI# Leakage Current	I <sub>PSI#</sub>	PSI# = 0V	<b>-1</b>	0		μA
		PSI# = 1V		0.45	<b>1</b>	μA
DPRSLPVR Leakage Current	I <sub>DPRSLPVR</sub>	DPRSLPVR = 0V	<b>-1</b>	0		μA
		DPRSLPVR = 1V		0.45	<b>1</b>	μA
<b>SLEW RATE</b>						
Slew Rate (For VID Change)	SR		<b>5</b>		<b>6.5</b>	mV/μs

**NOTES:**

6. Parameters with MIN and/or MAX limits are 100% tested at +25°C, unless otherwise specified. Temperature limits established by characterization and are not production tested.

## Gate Driver Timing Diagram





# Simplified Application Circuits

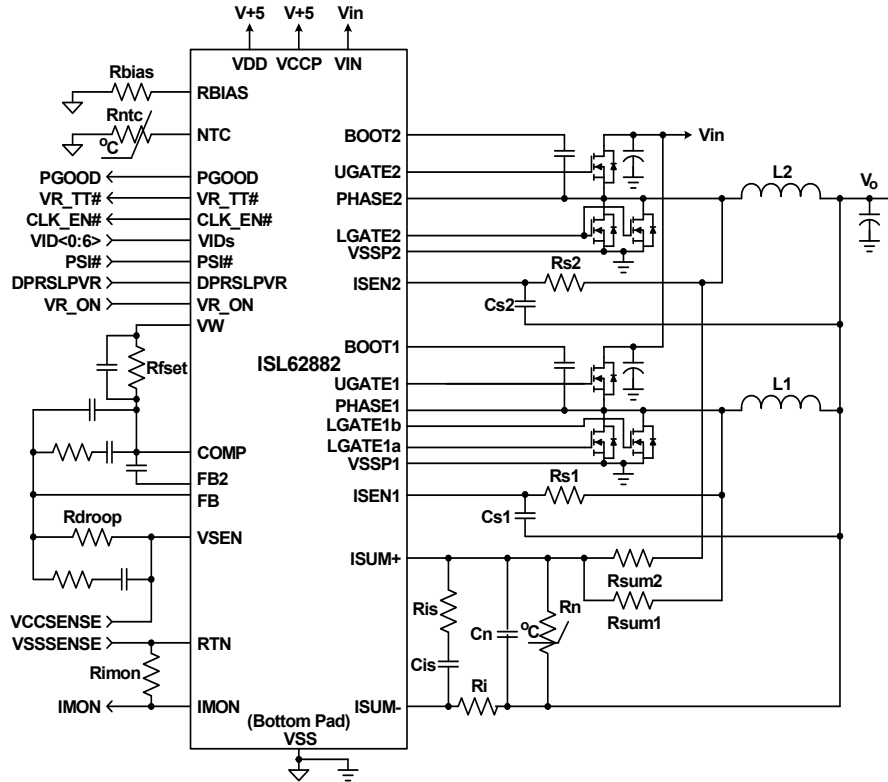


FIGURE 1. TYPICAL CPU APPLICATION CIRCUIT USING DCR SENSING

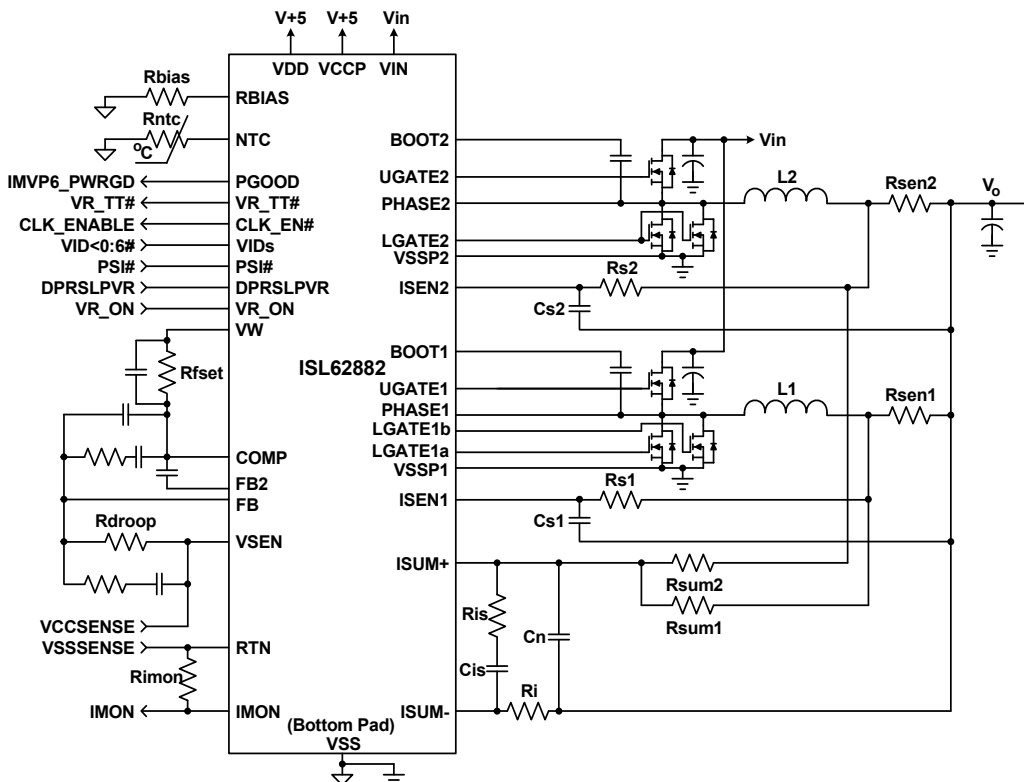


FIGURE 2. TYPICAL CPU APPLICATION CIRCUIT USING RESISTOR SENSING

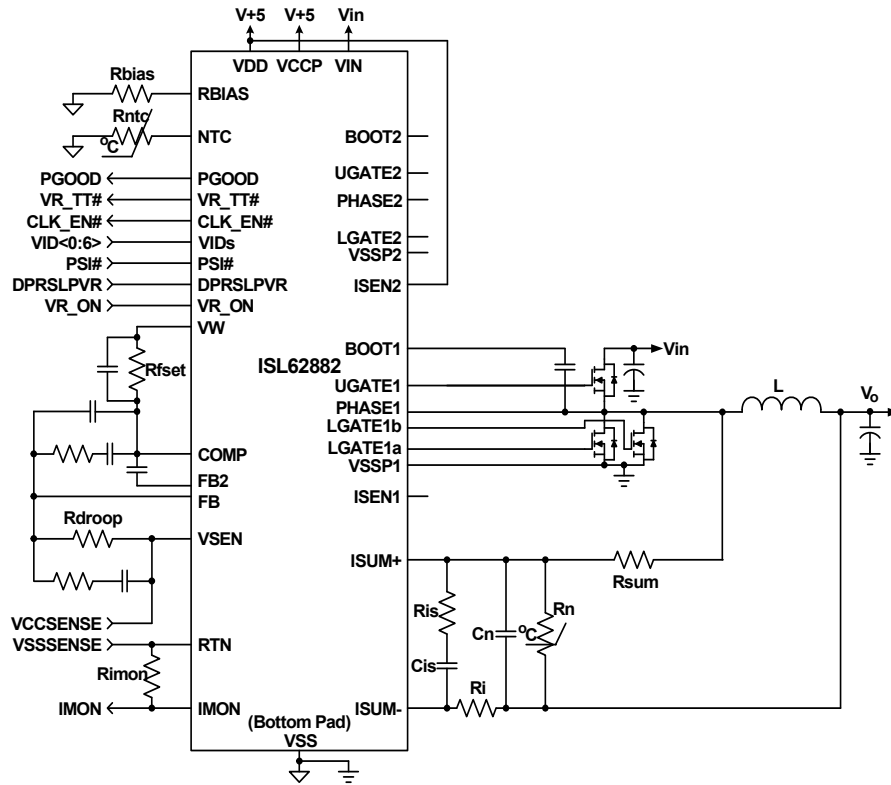


FIGURE 3. TYPICAL GPU APPLICATION CIRCUIT USING DCR SENSING

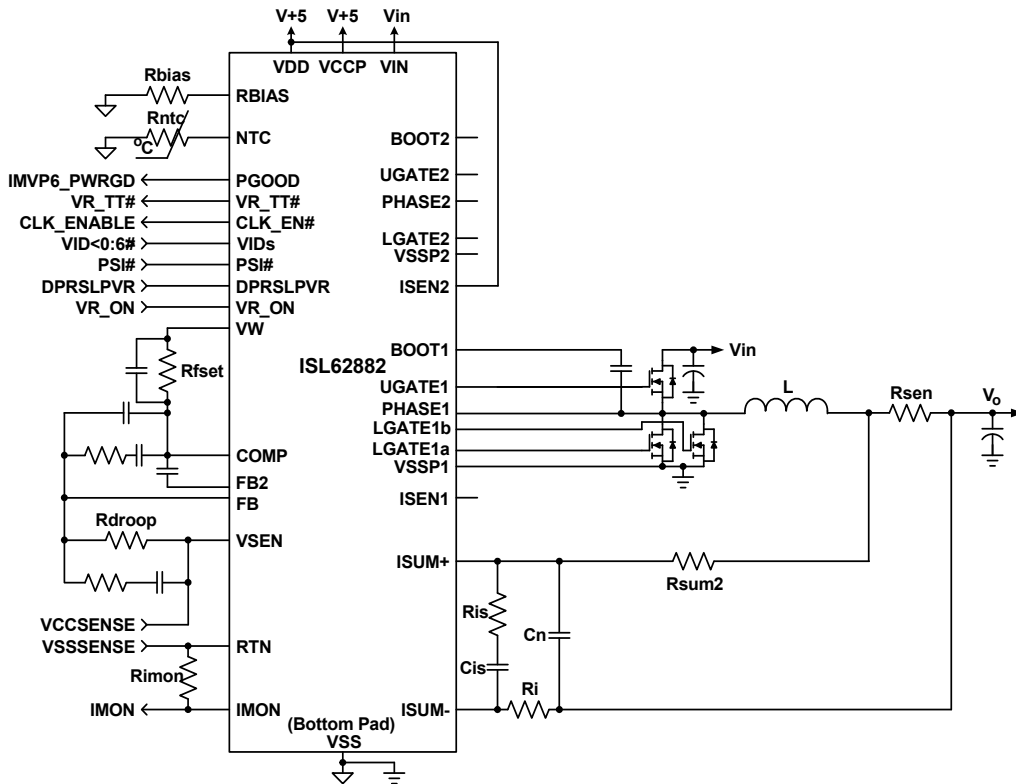


FIGURE 4. TYPICAL GPU APPLICATION CIRCUIT USING RESISTOR SENSING

# Theory of Operation

## Multiphase R<sup>3</sup>™ Modulator

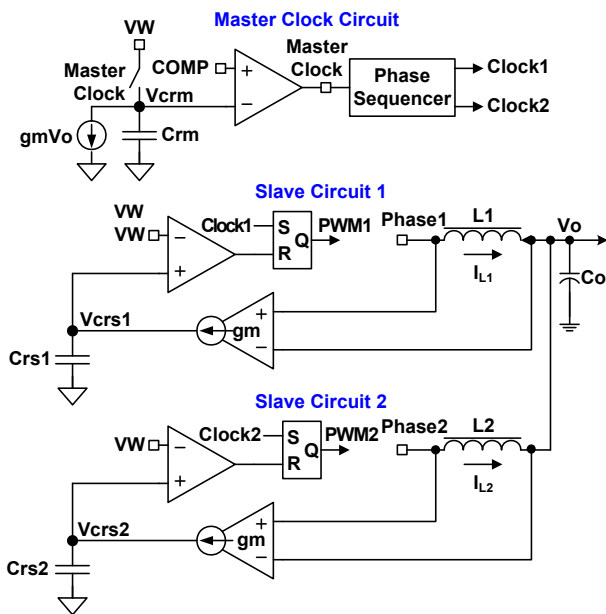


FIGURE 5. R<sup>3</sup>™ MODULATOR CIRCUIT

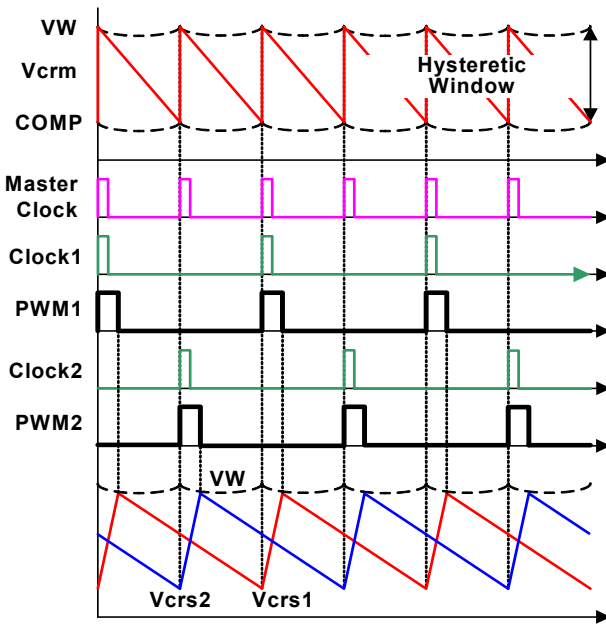


FIGURE 6. R<sup>3</sup>™ MODULATOR OPERATION PRINCIPLES IN STEADY STATE

Since the ISL62882 works with  $V_{crs}$ , which are large amplitude and noise-free synthesized signals, the ISL62882 achieves lower phase jitter than conventional hysteretic mode and fixed PWM

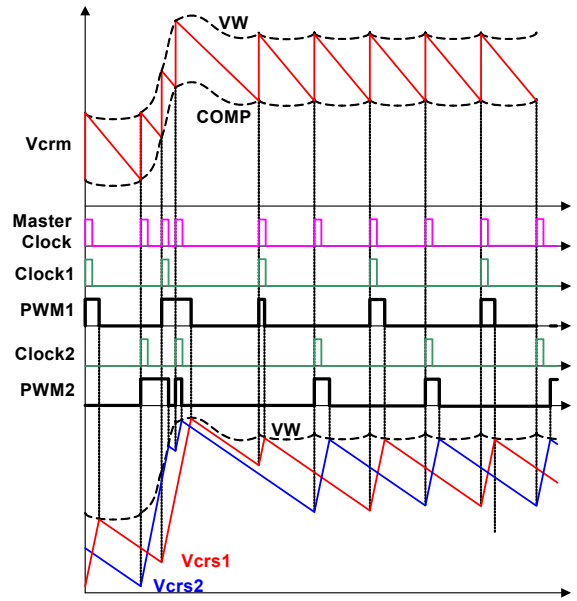


FIGURE 7. R<sup>3</sup>™ MODULATOR OPERATION PRINCIPLES IN LOAD INSERTION RESPONSE

The ISL62882 is a multiphase regulator implementing Intel® IMVP-6.5™ protocol. It can be programmed for 1- or 2-phase operation for microprocessor core applications. It uses Intel's patented R<sup>3</sup>™ (Robust Ripple Regulator™) modulator. The R<sup>3</sup>™ modulator combines the best features of fixed frequency PWM and hysteretic PWM while eliminating many of their shortcomings. Figure 5 conceptually shows the ISL62882 multiphase R<sup>3</sup>™ modulator circuit, and Figure 6 shows the operation principles.

A current source flows from the VW pin to the COMP pin, creating a voltage window set by the resistor between the two pins. This voltage window is called VW window in the following discussion.

Inside the IC, the modulator uses the master clock circuit to generate the clocks for the slave circuits. The modulator discharges the ripple capacitor  $C_{rm}$  with a current source equal to  $g_m V_o$ , where  $g_m$  is a gain factor.  $C_{rm}$  voltage  $V_{crm}$  is a sawtooth waveform traversing between the VW and COMP voltages. It resets to VW when it hits COMP, and generates a one-shot master clock signal. A phase sequencer distributes the master clock signal to the slave circuits. If the ISL62882 is in 2-phase mode, the master clock signal will be distributed to Phases 1 and 2, and the Clock1 and Clock2 signals will be 180° out-of-phase. If the ISL62882 is in 1-phase mode, the master clock signal will be distributed to Phases 1 only and be the Clock1 signal.

Each slave circuit has its own ripple capacitor  $C_{rs}$ , whose voltage mimics the inductor ripple current. A  $g_m$  amplifier converts the inductor voltage into a current source to charge and discharge  $C_{rs}$ . The slave circuit turns on its PWM pulse upon receiving the clock signal, and the current source charges  $C_{rs}$ . When  $C_{rs}$  voltage  $V_{crs}$  hits VW, the slave circuit turns off the PWM pulse, and the current source discharges  $C_{rs}$ .

mode controllers. Unlike conventional hysteretic mode converters, the ISL62882 has an error amplifier that allows the controller to maintain a 0.5% output voltage accuracy.

Figure 7 shows the operation principles during load insertion response. The COMP voltage rises during load insertion, generating the master clock signal more quickly, so the PWM pulses turn on earlier, increasing the effective switching frequency, which allows for higher control loop bandwidth than conventional fixed frequency PWM controllers. The VW voltage rises as the COMP voltage rises, making the PWM pulses wider. During load release response, the COMP voltage falls. It takes the master clock circuit longer to generate the next master clock signal so the PWM pulse is held off until needed. The VW voltage falls as the VW voltage falls, reducing the current PWM pulse width. This kind of behavior gives the ISL62882 excellent response speed.

The fact that both phases share the same VW window voltage also ensures excellent dynamic current balance between phases.

### Diode Emulation and Period Stretching

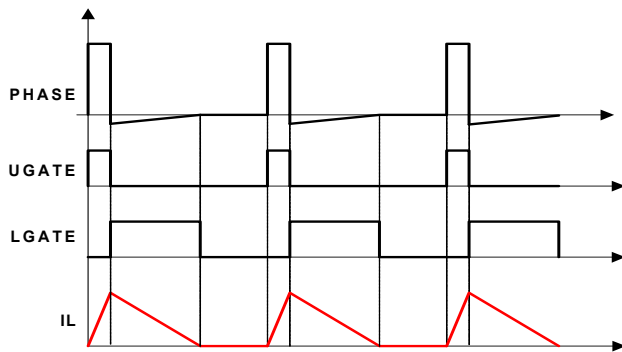


FIGURE 8. DIODE EMULATION

ISL62882 can operate in diode emulation (DE) mode to improve light load efficiency. In DE mode, the low-side MOSFET conducts when the current is flowing from source to drain and does not allow reverse current, emulating a diode. As Figure 8 shows, when LGATE is on, the low-side MOSFET carries current, creating negative voltage on the phase node due to the voltage drop across the ON-resistance. The ISL62882 monitors the current through monitoring the phase node voltage. It turns off LGATE when the phase node voltage reaches zero to prevent the inductor current from reversing the direction and creating unnecessary power loss.

If the load current is light enough, as Figure 8 shows, the inductor current will reach and stay at zero before the next phase node pulse, and the regulator is in discontinuous conduction mode (DCM). If the load current is heavy enough, the inductor current will never reach 0A, and the regulator is in CCM although the controller is in DE mode.

Figure 9 shows the operation principle in diode emulation mode at light load. The load gets incrementally lighter in the three cases from top to bottom. The PWM on-time is determined by the VW window size, therefore is the same, making the inductor current triangle the same in the three cases. The ISL62882 clamps the ripple capacitor voltage  $V_{CRS}$  in DE mode to make it mimic the

inductor current. It takes the COMP voltage longer to hit  $V_{CRS}$ , naturally stretching the switching period. The inductor current triangles move further apart from each other such that the inductor current average value is equal to the load current. The reduced switching frequency helps to increase light load efficiency.

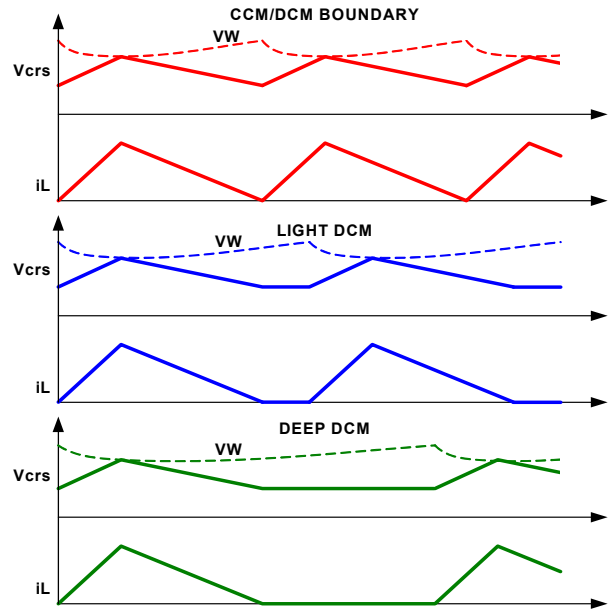


FIGURE 9. PERIOD STRETCHING

### Start-up Timing

With the controller's  $V_{DD}$  voltage above the POR threshold, the start-up sequence begins when  $VR_{ON}$  exceeds the 3.3V logic high threshold. Figure 10 shows the typical start-up timing when the ISL62882 is configured for CPU VR application. The ISL62882 uses digital soft-start to ramp-up DAC to the boot voltage of 1.1V at about  $2.5mV/\mu s$ . Once the output voltage is within 10% of the boot voltage for 13 PWM cycles ( $43\mu s$  for frequency = 300kHz),  $CLK_{EN\#}$  is pulled low and DAC slews at  $5mV/\mu s$  to the voltage set by the VID pins. PGOOD is asserted high in approximately 7ms. Similar results occur if  $VR_{ON}$  is tied to  $V_{DD}$ , with the soft-start sequence starting  $120\mu s$  after  $V_{DD}$  crosses the POR threshold.

Figure 11 shows the typical start-up timing when the ISL62882 is configured for GPU VR application. The ISL62882 uses digital soft start to ramp up DAC to the voltage set by the VID pins. The slew rate is  $5mV/\mu s$  when there is  $DPRSLPVR = 0$ , and is doubled when there is  $DPRSLPVR = 1$ . Once the output voltage is within 10% of the target voltage for 13 PWM cycles ( $43\mu s$  for frequency = 300kHz),  $CLK_{EN\#}$  is pulled low. PGOOD is asserted high in approximately 7ms. Similar results occur if  $VR_{ON}$  is tied to  $V_{DD}$ , with the soft-start sequence starting  $120\mu s$  after  $V_{DD}$  crosses the POR threshold.

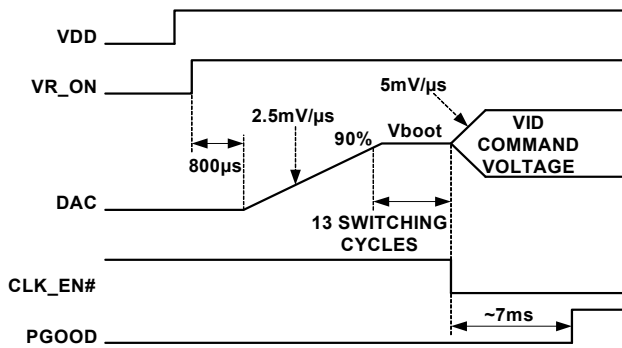


FIGURE 10. SOFT-START WAVEFORMS FOR CPU VR APPLICATION

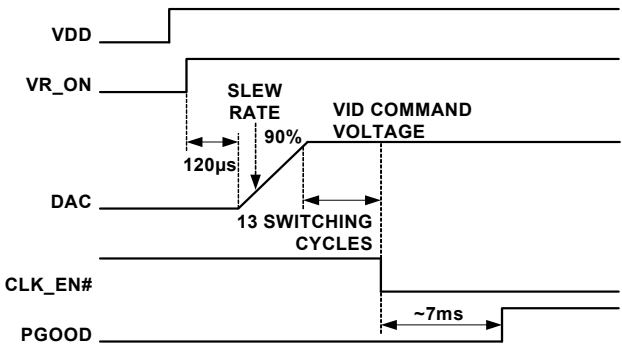


FIGURE 11. SOFT-START WAVEFORMS FOR GPU VR APPLICATION

### Voltage Regulation and Load Line Implementation

After the start sequence, the ISL62882 regulates the output voltage to the value set by the VID inputs per Table 1. The ISL62882 will control the no-load output voltage to an accuracy of  $\pm 0.5\%$  over the range of 0.75V to 1.5V. A differential amplifier allows voltage sensing for precise voltage regulation at the microprocessor die.

TABLE 1. VID TABLE

VID6	VID5	VID4	VID3	VID2	VID1	VID0	V <sub>O</sub> (V)
0	0	0	0	0	0	0	1.5000
0	0	0	0	0	0	1	1.4875
0	0	0	0	0	1	0	1.4750
0	0	0	0	0	1	1	1.4625
0	0	0	0	1	0	0	1.4500
0	0	0	0	1	0	1	1.4375
0	0	0	0	1	1	0	1.4250
0	0	0	0	1	1	1	1.4125
0	0	0	1	0	0	0	1.4000
0	0	0	1	0	0	1	1.3875
0	0	0	1	0	1	0	1.3750
0	0	0	1	0	1	1	1.3625

TABLE 1. VID TABLE (Continued)

VID6	VID5	VID4	VID3	VID2	VID1	VID0	V <sub>O</sub> (V)
0	0	0	1	1	0	0	1.3500
0	0	0	1	1	0	1	1.3375
0	0	0	1	1	1	0	1.3250
0	0	0	1	1	1	1	1.3125
0	0	1	0	0	0	0	1.3000
0	0	1	0	0	0	1	1.2875
0	0	1	0	0	1	0	1.2750
0	0	1	0	0	1	1	1.2625
0	0	1	0	1	0	0	1.2500
0	0	1	0	1	0	1	1.2375
0	0	1	0	1	1	0	1.2250
0	0	1	0	1	1	1	1.2125
0	0	1	1	0	0	0	1.2000
0	0	1	1	0	0	1	1.1875
0	0	1	1	0	1	0	1.1750
0	0	1	1	0	1	1	1.1625
0	0	1	1	1	0	0	1.1500
0	0	1	1	1	0	1	1.1375
0	0	1	1	1	1	0	1.1250
0	0	1	1	1	1	1	1.1125
0	1	0	0	0	0	0	1.1000
0	1	0	0	0	0	1	1.0875
0	1	0	0	0	1	0	1.0750
0	1	0	0	0	1	1	1.0625
0	1	0	0	1	0	0	1.0500
0	1	0	0	1	0	1	1.0375
0	1	0	0	1	1	0	1.0250
0	1	0	0	1	1	1	1.0125
0	1	0	1	0	0	0	1.0000
0	1	0	1	0	0	1	0.9875
0	1	0	1	0	1	0	0.9750
0	1	0	1	0	1	1	0.9625
0	1	0	1	1	0	0	0.9500
0	1	0	1	1	0	1	0.9375
0	1	0	1	1	1	0	0.9250
0	1	0	1	1	1	1	0.9125
0	1	1	0	0	0	0	0.9000
0	1	1	0	0	0	1	0.8875
0	1	1	0	0	1	0	0.8750

TABLE 1. VID TABLE (Continued)

VID6	VID5	VID4	VID3	VID2	VID1	VID0	V <sub>0</sub> (V)
0	1	1	0	0	1	1	0.8625
0	1	1	0	1	0	0	0.8500
0	1	1	0	1	0	1	0.8375
0	1	1	0	1	1	0	0.8250
0	1	1	0	1	1	1	0.8125
0	1	1	1	0	0	0	0.8000
0	1	1	1	0	0	1	0.7875
0	1	1	1	0	1	0	0.7750
0	1	1	1	0	1	1	0.7625
0	1	1	1	1	0	0	0.7500
0	1	1	1	1	0	1	0.7375
0	1	1	1	1	1	0	0.7250
0	1	1	1	1	1	1	0.7125
1	0	0	0	0	0	0	0.7000
1	0	0	0	0	0	1	0.6875
1	0	0	0	0	1	0	0.6750
1	0	0	0	0	1	1	0.6625
1	0	0	0	1	0	0	0.6500
1	0	0	0	1	0	1	0.6375
1	0	0	0	1	1	0	0.6250
1	0	0	0	1	1	1	0.6125
1	0	0	1	0	0	0	0.6000
1	0	0	1	0	0	1	0.5875
1	0	0	1	0	1	0	0.5750
1	0	0	1	0	1	1	0.5625
1	0	0	1	1	0	0	0.5500
1	0	0	1	1	0	1	0.5375
1	0	0	1	1	1	0	0.5250
1	0	0	1	1	1	1	0.5125
1	0	1	0	0	0	0	0.5000
1	0	1	0	0	0	1	0.4875
1	0	1	0	0	1	0	0.4750
1	0	1	0	0	1	1	0.4625
1	0	1	0	1	0	0	0.4500
1	0	1	0	1	0	1	0.4375
1	0	1	0	1	1	0	0.4250
1	0	1	0	1	1	1	0.4125
1	0	1	1	0	0	0	0.4000
1	0	1	1	0	0	1	0.3875

TABLE 1. VID TABLE (Continued)

VID6	VID5	VID4	VID3	VID2	VID1	VID0	V <sub>0</sub> (V)
1	0	1	1	0	1	0	0.3750
1	0	1	1	0	1	1	0.3625
1	0	1	1	1	0	0	0.3500
1	0	1	1	1	0	1	0.3375
1	0	1	1	1	1	0	0.3250
1	0	1	1	1	1	1	0.3125
1	1	0	0	0	0	0	0.3000
1	1	0	0	0	0	1	0.2875
1	1	0	0	0	1	0	0.2750
1	1	0	0	0	1	1	0.2625
1	1	0	0	1	0	0	0.2500
1	1	0	0	1	0	1	0.2375
1	1	0	0	1	1	0	0.2250
1	1	0	0	1	1	1	0.2125
1	1	0	1	0	0	0	0.2000
1	1	0	1	0	0	1	0.1875
1	1	0	1	0	1	0	0.1750
1	1	0	1	0	1	1	0.1625
1	1	0	1	1	0	0	0.1500
1	1	0	1	1	0	1	0.1375
1	1	0	1	1	1	0	0.1250
1	1	0	1	1	1	1	0.1125
1	1	1	0	0	0	0	0.1000
1	1	1	0	0	0	1	0.0875
1	1	1	0	0	1	0	0.0750
1	1	1	0	0	1	1	0.0625
1	1	1	0	1	0	0	0.0500
1	1	1	0	1	0	1	0.0375
1	1	1	0	1	1	0	0.0250
1	1	1	0	1	1	1	0.0125
1	1	1	1	0	0	0	0.0000
1	1	1	1	0	0	1	0.0000
1	1	1	1	0	1	0	0.0000
1	1	1	1	0	1	1	0.0000
1	1	1	1	1	0	0	0.0000
1	1	1	1	1	0	1	0.0000
1	1	1	1	1	1	0	0.0000
1	1	1	1	1	1	1	0.0000

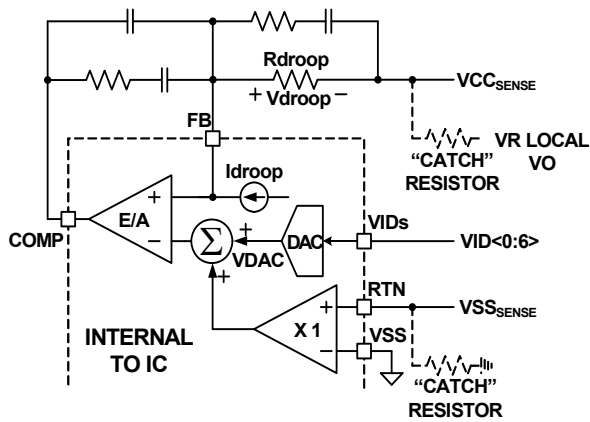


FIGURE 12. DIFFERENTIAL SENSING AND LOAD LINE IMPLEMENTATION

As the load current increases from zero, the output voltage will droop from the VID table value by an amount proportional to the load current to achieve the load line. The ISL62882 can sense the inductor current through the intrinsic DC Resistance (DCR) of the inductors as shown in Figure 1 or through resistors in series with the inductors as shown in Figure 2. In both methods, capacitor  $C_n$  voltage represents the inductor total currents. A droop amplifier converts  $C_n$  voltage into an internal current source with the gain set by resistor  $R_i$ . The current source is used for load line implementation, current monitor and overcurrent protection.

Figure 12 shows the load line implementation. The ISL62882 drives a current source  $I_{droop}$  out of the FB pin, described by Equation 1.

$$I_{droop} = \frac{2 \times V_{Cn}}{R_i} \quad (\text{EQ. 1})$$

When using inductor DCR current sensing, a single NTC element is used to compensate the positive temperature coefficient of the copper winding thus sustaining the load line accuracy with reduced cost.

$I_{droop}$  flows through resistor  $R_{droop}$  and creates a voltage drop as shown in Equation 2.

$$V_{droop} = R_{droop} \times I_{droop} \quad (\text{EQ. 2})$$

$V_{droop}$  is the droop voltage required to implement load line. Changing  $R_{droop}$  or scaling  $I_{droop}$  can both change the load line slope. Since  $I_{droop}$  also sets the overcurrent protection level, it is recommended to first scale  $I_{droop}$  based on OCP requirement, then select an appropriate  $R_{droop}$  value to obtain the desired load line slope.

## Differential Sensing

Figure 12 also shows the differential voltage sensing scheme.  $V_{CCSENSE}$  and  $V_{SSSENSE}$  are the remote voltage sensing signals from the processor die. A unity gain differential amplifier senses the  $V_{SSSENSE}$  voltage and add it to the DAC output. The error amplifier regulates the inverting and the non-inverting input voltages to be equal as shown in Equation 3:

$$V_{CCSENSE} + V_{droop} = V_{DAC} + V_{SSSENSE} \quad (\text{EQ. 3})$$

Rewriting Equation 3 and substitution of Equation 2 gives:

$$V_{CCSENSE} - V_{SSSENSE} = V_{DAC} - R_{droop} \times I_{droop} \quad (\text{EQ. 4})$$

Equation 4 is the exact equation required for load line implementation.

The  $V_{CCSENSE}$  and  $V_{SSSENSE}$  signals come from the processor die. The feedback will be open circuit in the absence of the processor. As Figure 12 shows, it is recommended to add a "catch" resistor to feed the VR local output voltage back to the compensator, and add another "catch" resistor to connect the VR local output ground to the RTN pin. These resistors, typically  $10\Omega \sim 100\Omega$ , will provide voltage feedback if the system is powered up without a processor installed.

## Phase Current Balancing

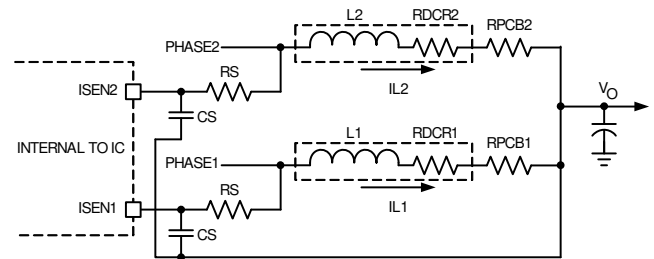


FIGURE 13. CURRENT BALANCING CIRCUIT

The ISL62882 monitors individual phase average current by monitoring the ISEN1 and ISEN2 voltages. Figure 13 shows the current balancing circuit recommended for ISL62882. Each phase node voltage is averaged by a low-pass filter consisting of  $R_s$  and  $C_s$ , and presented to the corresponding ISEN pin.  $R_s$  should be routed to inductor phase-node pad in order to eliminate the effect of phase node parasitic PCB DCR. Equations 5 and 6 give the ISEN pin voltages:

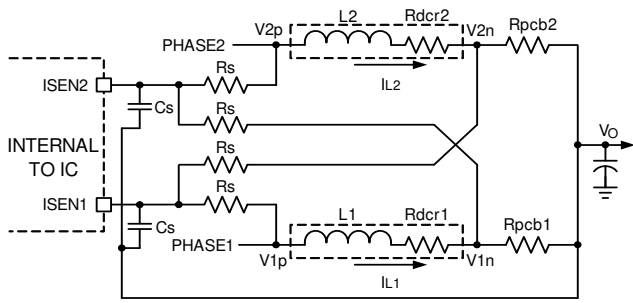
$$V_{ISEN1} = (R_{dcr1} + R_{pcb1}) \times I_{L1} \quad (\text{EQ. 5})$$

$$V_{ISEN2} = (R_{dcr2} + R_{pcb2}) \times I_{L2} \quad (\text{EQ. 6})$$

where  $R_{dcr1}$  and  $R_{dcr2}$  are inductor DCR;  $R_{pcb1}$  and  $R_{pcb2}$  are parasitic PCB DCR between the inductor output side pad and the output voltage rail; and  $I_{L1}$  and  $I_{L2}$  are inductor average currents.

The ISL62882 will adjust the phase pulse-width relative to the other phase to make  $V_{ISEN1} = V_{ISEN2}$ , thus to achieve  $I_{L1} = I_{L2}$ , when there are  $R_{dcr1} = R_{dcr2}$  and  $R_{pcb1} = R_{pcb2}$ .

Using same components for L1 and L2 will provide a good match of  $R_{dcr1}$  and  $R_{dcr2}$ . Board layout will determine  $R_{pcb1}$  and  $R_{pcb2}$ . It is recommended to have symmetrical layout for the power delivery path between each inductor and the output voltage rail, such that  $R_{pcb1} = R_{pcb2}$ .



**FIGURE 14. DIFFERENTIAL-SENSING CURRENT BALANCING CIRCUIT**

Sometimes, it is difficult to implement symmetrical layout. For the circuit Figure 13 shows, asymmetric layout causes different  $R_{pcb1}$  and  $R_{pcb2}$  thus current imbalance. Figure 14 shows a differential-sensing current balancing circuit recommended for ISL62882. The current sensing traces should be routed to the inductor pads so they only pick up the inductor DCR voltage. Each ISEN pin sees the average voltage of two sources: its own phase inductor phase-node pad, and the other phase inductor output side pad. Equations 7 and 8 give the ISEN pin voltages:

$$V_{ISEN1} = V_{1p} + V_{2n} \quad (EQ. 7)$$

$$V_{ISEN2} = V_{2p} + V_{1n} \quad (EQ. 8)$$

The ISL62882 will make  $V_{ISEN1} = V_{ISEN2}$ . So there are:

$$V_{1p} + V_{2n} = V_{2p} + V_{1n} \quad (EQ. 9)$$

Rewriting Equation 9 gives:

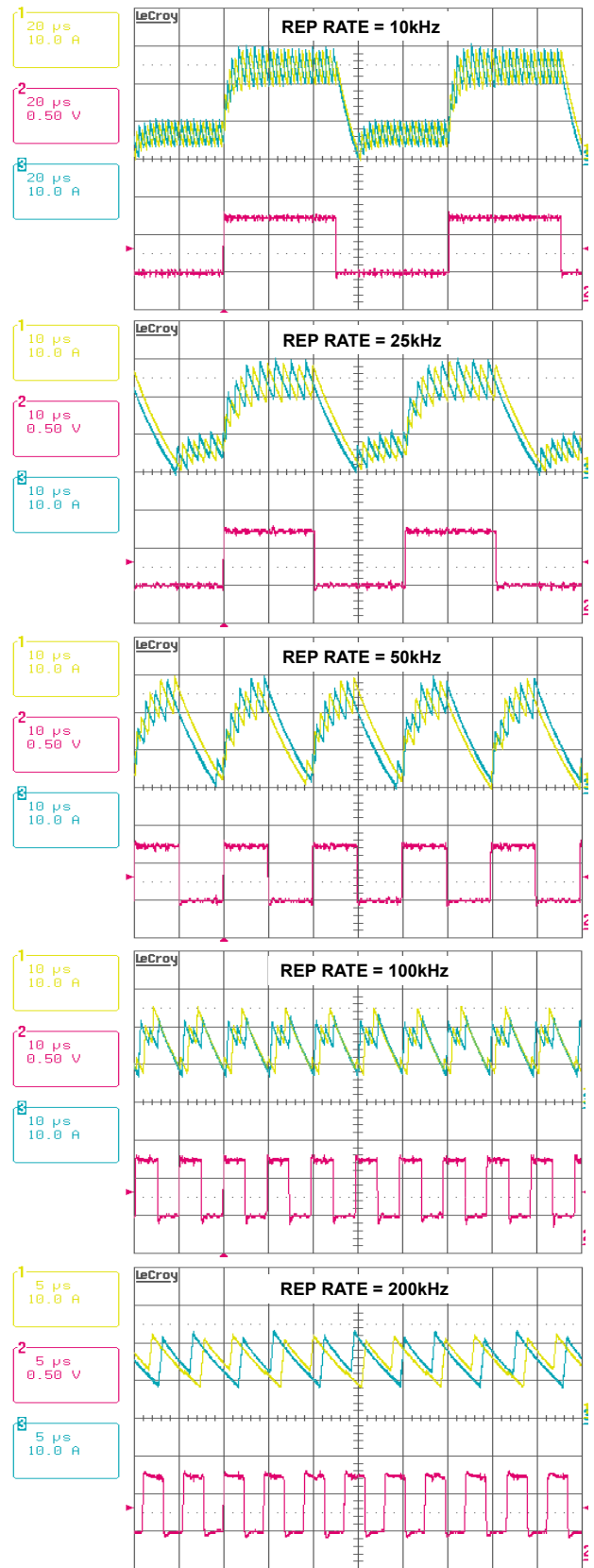
$$V_{1p} - V_{1n} = V_{2p} - V_{2n} \quad (EQ. 10)$$

Therefore:

$$R_{dcr1} \times I_{L1} = R_{dcr2} \times I_{L2} \quad (EQ. 11)$$

Current balancing ( $I_{L1} = I_{L2}$ ) will be achieved when there is  $R_{dcr1} = R_{dcr2}$ .  $R_{pcb1}$  and  $R_{pcb2}$  will not have any effect.

Since the slave ripple capacitor voltages mimic the inductor currents,  $R^3$ ™ modulator can naturally achieve excellent current balancing during steady state and dynamic operations. Figure 15 shows current balancing performance of the ISL62882 evaluation board with load transient of 15A/50A at different rep rates. The inductor currents follow the load current dynamic change with the output capacitors supplying the difference. The inductor currents can track the load current well at a low rep rate, but cannot keep up when the rep rate gets into the hundred-kHz range, where it's out of the control loop bandwidth. The controller achieves excellent current balancing in all cases.



**FIGURE 15. ISL62882 EVALUATION BOARD CURRENT BALANCING DURING DYNAMIC OPERATION.**  
Ch1: IL1, Ch2:  $I_{load}$ , Ch3: IL2



## CCM Switching Frequency

The  $R_{fset}$  resistor between the COMP and the VW pins sets the VW windows size, therefore sets the switching frequency. When the ISL62882 is in continuous conduction mode (CCM), the switching frequency is not absolutely constant due to the nature of the  $R^3$ ™ modulator. As explained in the “Multiphase  $R^3$ ™ Modulator” on page 11, the effective switching frequency will increase during load insertion and will decrease during load release to achieve fast response. On the other hand, the switching frequency is relatively constant at steady state. Variation is expected when the power stage condition, such as input voltage, output voltage, load, etc. changes. The variation is usually less than 15% and doesn't have any significant effect on output voltage ripple magnitude. Equation 12 gives an estimate of the frequency-setting resistor  $R_{fset}$  value.  $8k\Omega R_{fset}$  gives approximately 300kHz switching frequency. Lower resistance gives higher switching frequency.

$$R_{fset}(k\Omega) = (\text{Period}(\mu\text{s}) - 0.29) \times 2.65 \quad (\text{EQ. 12})$$

## Modes of Operation

TABLE 2. ISL62882 CONFIGURATIONS

ISEN2	Rbias (kΩ)	CONFIGURATION	OVERSHOOT REDUCTION FUNCTION
Connected to the Power Stage	147	2-phase CPU VR	Disabled
	47		Enabled
Tied to 5V	147	1-phase CPU VR	See Table 4
	47	1-phase GPU VR	

TABLE 3. ISL62882 MODES OF OPERATION

CONFIG.	PSI#	DPRSLPVR	OPERATIONAL MODE	VOLTAGE SLEW RATE
2-phase CPU Configuration	0	0	1-phase CCM	5mV/μs
	0	1	1-phase DE	
	1	0	2-phase CCM	
	1	1	1-phase DE	
1-phase CPU Configuration	x	0	1-phase CCM	
		1	1-phase DE	
1-phase GPU Configuration	x	0	1-phase CCM	10mV/μs
		1	1-phase DE	

The ISL62882 can be configured for 2- or 1-phase operation.

For 1-phase configuration, tie the ISEN2 pin to 5V. In this configuration, only phase-1 is active.

Table 2 shows the ISL62882 configurations, programmed by the ISEN2 pin status and the Rbias value.

If the ISEN2 pin is connected to the power stage, the ISL62882 is in 2-phase CPU VR configuration. Rbias = 147kΩ disables the overshoot reduction function and Rbias = 47kΩ enables it.

If ISEN2 is tied to 5V, the ISL62882 is configured for 1-phase operation. Rbias = 147kΩ sets 1-phase CPU VR configuration and Rbias = 47kΩ sets 1-phase GPU configuration.

Table 3 shows the ISL62882 operational modes, programmed by the logic status of the PSI# and DPRSLPVR pins.

In 2-phase configuration, the ISL62882 enters 1-phase CCM for (PSI# = 0 and DPRSLPVR = 0). It drops phase 2 and reduces the overcurrent and the way-overcurrent protection levels to 1/2 of the initial values. The ISL62882 enters 1-phase DE mode when DPRSLPVR = 1 by dropping phase 2.

In 1-phase configuration, the ISL62882 does not change the operational mode when the PSI# signal changes status. It enters 1-phase DE mode when DLPRSLPVR = 1.

## Dynamic Operation

When the ISL62882 is configured for CPU VR application, it responds to VID changes by slewing to the new voltage at 5mV/μs slew rate. As the output approaches the VID command voltage, the dv/dt moderates to prevent overshoot. Geyserville-III transitions commands one LSB VID step (12.5mV) every 2.5μs, controlling the effective dv/dt at 5mV/μs. The ISL62882 is capable of 5mV/μs slew rate.

When the ISL62882 is configured for GPU VR application, it responds to VID changes by slewing to the new voltage at a slew rate set by the logic status on the DPRSLPVR pin. The slew rate is 5mV/μs when DPRSLPVR = 0 and is doubled when DPRSLPVR = 1.

When the ISL62882 is in DE mode, it will actively drive the output voltage up when the VID changes to a higher value. It'll resume DE mode operation after reaching the new voltage level. If the load is light enough to warrant DCM, it will enter DCM after the inductor current has crossed zero for four consecutive cycles. The ISL62882 will remain in DE mode when the VID changes to a lower value. The output voltage will decay to the new value and the load will determine the slew rate. Over-voltage protection is blanked during VID down transition in DE mode until the output voltage is within 60mV of the VID value.

During load insertion response, the Fast Clock function increases the PWM pulse response speed. The ISL62882 monitors the VSEN pin voltage and compares it to 100ns-filtered version. When the unfiltered version is 20mV below the filtered version, the controller knows there is a fast voltage dip due to load insertion, hence issues an additional master clock signal to deliver a PWM pulse immediately.

The  $R^3$ ™ modulator intrinsically has voltage feed-forward. The output voltage is insensitive to a fast slew rate input voltage change.

## Protections

The ISL62882 provides overcurrent, current-balance, undervoltage, overvoltage, and over-temperature protections.

The ISL62882 determines overcurrent protection (OCP) by comparing the average value of the droop current  $I_{droop}$  with an internal current source threshold. It declares OCP when  $I_{droop}$  is above the threshold for 120μs. A resistor  $R_{comp}$  from the COMP pin to GND programs the OCP current source threshold, as well

as the overshoot reduction function in 1-phase configuration, as Table 4 shows. It is recommended to use the nominal  $R_{comp}$  value. The ISL62882 detects the  $R_{comp}$  value at the beginning of start-up, and sets the internal OCP threshold accordingly. It remembers the  $R_{comp}$  value until the VR\_ON signal drops below the POR threshold.

**TABLE 4. ISL62882  $R_{comp}$  PROGRAMABILITY**

$R_{comp}$			2-PHASE CONFIG.	1-PHASE CONFIG.	
MIN (k $\Omega$ )	NOMINAL (k $\Omega$ )	MAX (k $\Omega$ )	OCP THRESHOLD ( $\mu$ A)		OVERSHOOT REDUCTION FUNCTION
	none	none	40	20	Disabled
320	400	480	45.3	22.7	
210	235	260	41.3	20.7	
155	165	175	36	18	
104	120	136	37.33	20	Enabled
78	85	92	38.7	22.7	
62	66	70	42.7	20.7	
45	50	55	44	18	

The default OCP threshold is the value when  $R_{comp}$  is not populated. It is recommended to scale the droop current  $I_{droop}$  such that the default OCP threshold gives approximately the desired OCP level, then use  $R_{comp}$  to fine tune the OCP level if necessary.

For overcurrent conditions above 2.5x the OCP level, the PWM outputs will immediately shut off and PGOOD will go low to maximize protection. This protection is also referred to as way-overcurrent protection or fast-overcurrent protection, for short-circuit protections.

The ISL62882 monitors the ISEN pin voltages to determine current-balance protection. If the ISEN pin voltage difference is greater than 9mV for 1ms, the controller will declare a fault and latch off.

The ISL62882 will declare undervoltage (UV) fault and latch off if the output voltage is less than the VID set value by 300mV or more for 1ms. It'll turn off the PWM outputs and de-assert PGOOD.

The ISL62882 has two levels of overvoltage protections. The first level of overvoltage protection is referred to as PGOOD overvoltage protection. If the output voltage exceeds the VID set value by +200mV for 1ms, the ISL62882 will declare a fault and de-assert PGOOD.

The ISL62882 takes the same actions for all of the above fault protections: de-assertion of PGOOD and turn-off of the high-side and low-side power MOSFETs. Any residual inductor current will decay through the MOSFET body diodes. These fault conditions can be reset by bringing VR\_ON low or by bringing  $V_{DD}$  below the POR threshold. When VR\_ON and  $V_{DD}$  return to their high operating levels, a soft-start will occur.

The second level of overvoltage protection is different. If the output voltage exceeds 1.55V, the ISL62882 will immediately declare an OV fault, de-assert PGOOD, and turn on the low-side power MOSFETs. The low-side power MOSFETs remain on until the output voltage is pulled down below 0.85V when all power MOSFETs are turned off. If the output voltage rises above 1.55V again, the protection process is repeated. This behavior provides the maximum amount of protection against shorted high-side power MOSFETs while preventing output ringing below ground. Resetting VR\_ON cannot clear the 1.55V OVP. Only resetting  $V_{DD}$  will clear it. The 1.55V OVP is active all the time when the controller is enabled, even if one of the other faults have been declared. This ensures that the processor is protected against high-side power MOSFET leakage while the MOSFETs are commanded off.

The ISL62882 has a thermal throttling feature. If the voltage on the NTC pin goes below the 1.18V OT threshold, the VR\_TT# pin is pulled low indicating the need for thermal throttling to the system. No other action is taken within the ISL62882 in response to NTC pin voltage.

Table 5 summarizes the fault protections.

**TABLE 5. FAULT PROTECTION SUMMARY**

FAULT TYPE	FAULT DURATION BEFORE PROTECTION	PROTECTION ACTION	FAULT RESET
Overcurrent	120 $\mu$ s	PWM tri-state, PGOOD latched low	VR_ON toggle or VDD toggle
Way-Overcurrent (2.5xOC)	<2 $\mu$ s		
Overvoltage +200mV	1ms		
Undervoltage -300mV			
Phase Current Unbalance			
Overvoltage 1.55V	Immediately	Low-side MOSFET on until $V_{CORE}$ <0.85V, then PWM tri-state, PGOOD latched low.	VDD toggle
Over-Temperature		1ms	N/A

## Current Monitor

The ISL62882 provides the current monitor function. The IMON pin outputs a high-speed analog current source that is 3 times of the droop current flowing out of the FB pin. Thus Equation 13:

$$I_{\text{IMON}} = 3 \times I_{\text{droop}} \quad (\text{EQ. 13})$$

As Figures 1 and 2 show, a resistor  $R_{\text{imon}}$  is connected to the IMON pin to convert the IMON pin current to voltage. A capacitor can be paralleled with  $R_{\text{imon}}$  to filter the voltage information. The IMVP-6.5™ specification requires that the IMON voltage information be referenced to  $V_{\text{SSSENSE}}$ .

The IMON pin voltage range is 0V to 1.1V. A clamp circuit prevents the IMON pin voltage from going above 1.1V.

## FB2 Function

The FB2 function is only available when the ISL62882 is in 2-phase configuration.

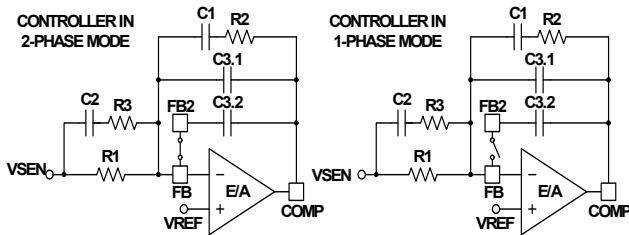


FIGURE 16. FB2 FUNCTION IN 2-PHASE MODE

Figure 16 shows the FB2 function. A switch (called FB2 switch) turns on to short the FB and the FB2 pins when the controller is in 2-phase mode. Capacitors C3.1 and C3.2 are in parallel, serving as part of the compensator. When the controller enters 1-phase mode, the FB2 switch turns off, removing C3.2 and leaving only C3.1 in the compensator. The compensator gain will increase with the removal of C3.2. By properly sizing C3.1 and C3.2, the compensator can be optimal for both 2-phase mode and 1-phase mode.

When the FB2 switch is off, C3.2 is disconnected from the FB pin. However, the controller still actively drives the FB2 pin voltage to follow the FB pin voltage such that C3.2 voltage always follows C3.1 voltage. When the controller turns on the FB2 switch, C3.2 will be reconnected to the compensator smoothly.

The FB2 function ensures excellent transient response in both 2-phase mode and 1-phase mode. If one decides not to use the FB2 function, simply populate C3.1 only.

## Adaptive Body Diode Conduction Time Reduction

In DCM, the controller turns off the low-side MOSFET when the inductor current approaches zero. During on-time of the low-side MOSFET, phase voltage is negative and the amount is the MOSFET  $r_{\text{DS(ON)}}$  voltage drop, which is proportional to the inductor current. A phase comparator inside the controller monitors the phase voltage during on-time of the low-side MOSFET and compares it with a threshold to determine the zero-crossing point of the inductor current. If the inductor current

has not reached zero when the low-side MOSFET turns off, it'll flow through the low-side MOSFET body diode, causing the phase node to have a larger voltage drop until it decays to zero. If the inductor current has crossed zero and reversed the direction when the low-side MOSFET turns off, it'll flow through the high-side MOSFET body diode, causing the phase node to have a spike until it decays to zero. The controller continues monitoring the phase voltage after turning off the low-side MOSFET and adjusts the phase comparator threshold voltage accordingly in iterative steps such that the low-side MOSFET body diode conducts for approximately 40ns to minimize the body diode-related loss.

## Overshoot Reduction Function

The ISL62882 has an optional overshoot reduction function. Tables 2 and 4 show to enable and disable it.

When a load release occurs, the energy stored in the inductors will dump to the output capacitor, causing output voltage overshoot. The inductor current freewheels through the low-side MOSFET during this period of time. The overshoot reduction function turns off the low-side MOSFET during the output voltage overshoot, forcing the inductor current to freewheel through the low-side MOSFET body diode. Since the body diode voltage drop is much higher than MOSFET  $R_{\text{dson}}$  voltage drop, more energy is dissipated on the low-side MOSFET therefore the output voltage overshoot is lower.

If the overshoot reduction function is enabled, the ISL62882 monitors the COMP pin voltage to determine the output voltage overshoot condition. The COMP voltage will fall and hit the clamp voltage when the output voltage overshoots. The ISL62882 will turn off LGATE1 and LGATE2 when COMP is being clamped. All the low-side MOSFETs in the power stage will be turned off. When the output voltage has reached its peak and starts to come down, the COMP voltage starts to rise and is no longer clamped. The ISL62882 will resume normal PWM operation.

When  $\text{PSI\#}$  is low, indicating a low power state of the CPU, the controller will disable the overshoot reduction function as large magnitude transient event is not expected and overshoot is not a concern.

While the overshoot reduction function reduces the output voltage overshoot, energy is dissipated on the low-side MOSFET, causing additional power loss. The more frequent transient event, the more power loss dissipated on the low-side MOSFET. The MOSFET may face severe thermal stress when transient events happen at a high repetitive rate. User discretion is advised when this function is enabled.

## Key Component Selection

### R<sub>BIAS</sub>

The ISL62882 uses a resistor (1% or better tolerance is recommended) from the R<sub>BIAS</sub> pin to GND to establish highly accurate reference current sources inside the IC. Refer to Table 2 to select the resistance according to desired configuration. Do not connect any other components to this pin. Do not connect any capacitor to the R<sub>BIAS</sub> pin as it will create instability.

Care should be taken in layout that the resistor is placed very close to the R<sub>BIAS</sub> pin and that a good quality signal ground is connected to the opposite side of the R<sub>BIAS</sub> resistor.

### R<sub>IS</sub> and C<sub>IS</sub>

As Figures 1 thru 4 show, the ISL62882 needs the R<sub>IS</sub> - C<sub>IS</sub> network across the ISUM+ and the ISUM- pins to stabilize the droop amplifier. The preferred values are R<sub>IS</sub> = 82.5Ω and C<sub>IS</sub> = 0.01μF. Slight deviations from the recommended values are acceptable. Large deviations may result in instability.

### Inductor DCR Current-Sensing Network

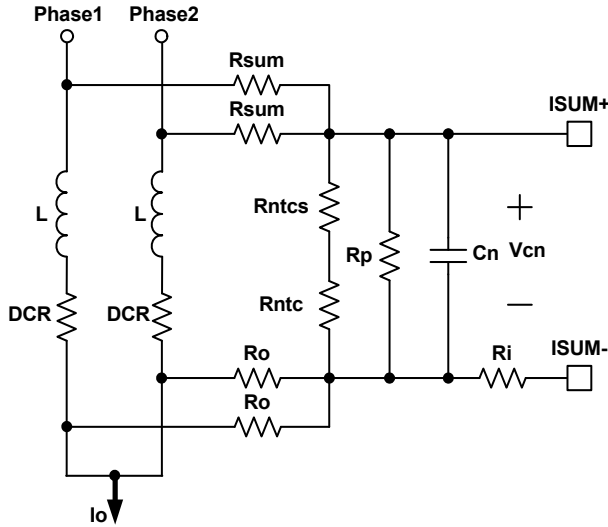


FIGURE 17. DCR CURRENT-SENSING NETWORK

Figure 17 shows the inductor DCR current-sensing network for a 2-phase solution. An inductor current flows through the DCR and creates a voltage drop. Each inductor has two resistors in R<sub>sum</sub> and R<sub>o</sub> connected to the pads to accurately sense the inductor current by sensing the DCR voltage drop. The R<sub>sum</sub> and R<sub>o</sub> resistors are connected in a summing network as shown, and feed the total current information to the NTC network (consisting of R<sub>ntcs</sub>, R<sub>ntc</sub> and R<sub>p</sub>) and capacitor C<sub>n</sub>. R<sub>ntc</sub> is a negative temperature coefficient (NTC) thermistor, used to temperature-compensate the inductor DCR change.

The inductor output side pads are electrically shorted in the schematic, but have some parasitic impedance in actual board layout, which is why one cannot simply short them together for the current-sensing summing network. It is recommended to use 1Ω~10Ω R<sub>o</sub> to create quality signals. Since R<sub>o</sub> value is much smaller than the rest of the current sensing circuit, the following analysis will ignore it for simplicity.

The summed inductor current information is presented to the capacitor C<sub>n</sub>. Equations 14 thru 18 describe the frequency-domain relationship between inductor total current I<sub>o</sub>(s) and C<sub>n</sub> voltage V<sub>Cn</sub>(s).

$$V_{Cn}(s) = \left( \frac{R_{ntcnet}}{R_{ntcnet} + \frac{R_{sum}}{N}} \times \frac{DCR}{N} \right) \times I_o(s) \times A_{cs}(s) \quad (EQ. 14)$$

$$R_{ntcnet} = \frac{(R_{ntcs} + R_{ntc}) \times R_p}{R_{ntcs} + R_{ntc} + R_p} \quad (EQ. 15)$$

$$A_{cs}(s) = \frac{1 + \frac{s}{\omega_L}}{1 + \frac{s}{\omega_{sns}}} \quad (EQ. 16)$$

$$\omega_L = \frac{DCR}{L} \quad (EQ. 17)$$

$$\omega_{sns} = \frac{1}{\frac{R_{ntcnet} \times \frac{R_{sum}}{N}}{R_{ntcnet} + \frac{R_{sum}}{N}} \times C_n} \quad (EQ. 18)$$

where N is the number of phases.

Transfer function A<sub>cs</sub>(s) always has unity gain at DC. The inductor DCR value increases as the winding temperature increases, giving higher reading of the inductor DC current. The NTC R<sub>ntc</sub> values decreases as its temperature decreases. Proper selections of R<sub>sum</sub>, R<sub>ntcs</sub>, R<sub>p</sub> and R<sub>ntc</sub> parameters ensure that V<sub>Cn</sub> represent the inductor total DC current over the temperature range of interest.

There are many sets of parameters that can properly temperature-compensate the DCR change. Since the NTC network and the R<sub>sum</sub> resistors form a voltage divider, V<sub>Cn</sub> is always a fraction of the inductor DCR voltage. It is recommended to have a higher ratio of V<sub>Cn</sub> to the inductor DCR voltage, so the droop circuit has higher signal level to work with.

A typical set of parameters that provide good temperature compensation are: R<sub>sum</sub> = 3.65kΩ, R<sub>p</sub> = 11kΩ, R<sub>ntcs</sub> = 2.61kΩ and R<sub>ntc</sub> = 10kΩ (ERT-J1VR103J). The NTC network parameters may need to be fine tuned on actual boards. One can apply full load DC current and record the output voltage reading immediately; then record the output voltage reading again when the board has reached the thermal steady state. A good NTC network can limit the output voltage drift to within 2mV. It is recommended to follow the Intersil evaluation board layout and current-sensing network parameters to minimize engineering time.

V<sub>Cn</sub>(s) also needs to represent real-time I<sub>o</sub>(s) for the controller to achieve good transient response. Transfer function A<sub>cs</sub>(s) has a pole ω<sub>sns</sub> and a zero ω<sub>L</sub>. One needs to match ω<sub>L</sub> and ω<sub>sns</sub> so A<sub>cs</sub>(s) is unity gain at all frequencies. By forcing ω<sub>L</sub> equal to ω<sub>sns</sub> and solving for the solution, Equation 19 gives C<sub>n</sub> value.

$$C_n = \frac{L}{\frac{R_{ntcnet} \times \frac{R_{sum}}{N}}{R_{ntcnet} + \frac{R_{sum}}{N}} \times DCR} \quad (EQ. 19)$$

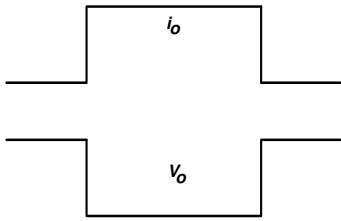


FIGURE 18. DESIRED LOAD TRANSIENT RESPONSE WAVEFORMS

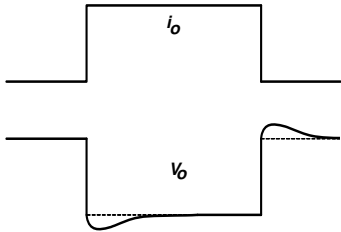


FIGURE 19. LOAD TRANSIENT RESPONSE WHEN  $C_n$  IS TOO SMALL

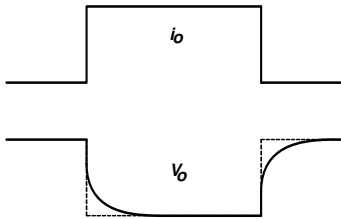


FIGURE 20. LOAD TRANSIENT RESPONSE WHEN  $C_n$  IS TOO LARGE

For example, given  $N = 2$ ,  $R_{sum} = 3.65k\Omega$ ,  $R_p = 11k\Omega$ ,  $R_{ntcs} = 2.61k\Omega$ ,  $R_{ntc} = 10k\Omega$ ,  $DCR = 0.88m\Omega$  and  $L = 0.36\mu H$ , Equation 19 gives  $C_n = 0.294\mu F$ .

Assuming the compensator design is correct, Figure 18 shows the expected load transient response waveforms if  $C_n$  is correctly selected. When the load current  $I_{core}$  has a square change, the output voltage  $V_{core}$  also has a square response.

If  $C_n$  value is too large or too small,  $V_{Cn}(s)$  will not accurately represent real-time  $I_o(s)$  and will worsen the transient response. Figure 19 shows the load transient response when  $C_n$  is too small.  $V_{core}$  will sag excessively upon load insertion and may create a system failure. Figure 20 shows the transient response when  $C_n$  is too large.  $V_{core}$  is sluggish in drooping to its final value. There will be excessive overshoot if load insertion occurs during this time, which may potentially hurt the CPU reliability.

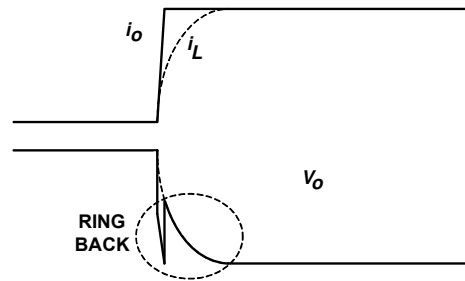


FIGURE 21. OUTPUT VOLTAGE RING BACK PROBLEM

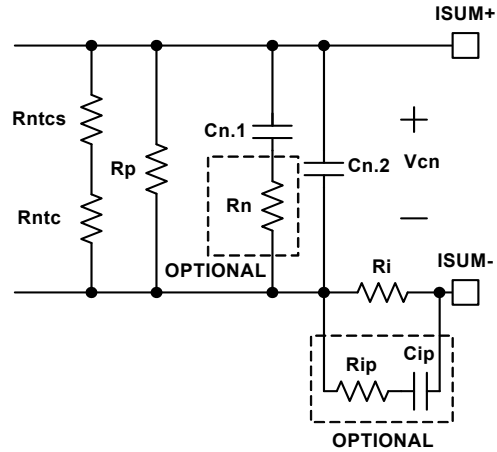


FIGURE 22. OPTIONAL CIRCUITS FOR RING BACK REDUCTION

Figure 21 shows the output voltage ring back problem during load transient response. The load current  $i_o$  has a fast step change, but the inductor current  $i_L$  cannot accurately follow. Instead,  $i_L$  responds in first order system fashion due to the nature of current loop. The ESR and ESL effect of the output capacitors makes the output voltage  $V_o$  dip quickly upon load current change. However, the controller regulates  $V_o$  according to the droop current  $i_{droop}$ , which is a real-time representation of  $i_L$ ; therefore it pulls  $V_o$  back to the level dictated by  $i_L$ , causing the ring back problem. This phenomenon is not observed when the output capacitor have very low ESR and ESL, such as all ceramic capacitors.

Figure 22 shows two optional circuits for reduction of the ring back.

$C_n$  is the capacitor used to match the inductor time constant. It usually takes the parallel of two (or more) capacitors to get the desired value. Figure 22 shows that two capacitors  $C_{n.1}$  and  $C_{n.2}$  are in parallel. Resistor  $R_n$  is an optional component to reduce the  $V_o$  ring back. At steady state,  $C_{n.1} + C_{n.2}$  provides the desired  $C_n$  capacitance. At the beginning of  $i_o$  change, the effective capacitance is less because  $R_n$  increases the impedance of the  $C_{n.1}$  branch. As Figure 19 explains,  $V_o$  tends to dip when  $C_n$  is too small, and this effect will reduce the  $V_o$  ring back. This effect is more pronounced when  $C_{n.1}$  is much larger than  $C_{n.2}$ . It is also more pronounced when  $R_n$  is bigger. However, the presence of  $R_n$  increases the ripple of the  $V_n$  signal if  $C_{n.2}$  is too small. It is recommended to keep  $C_{n.2}$  greater than 2200pF.  $R_n$  value usually is a few ohms.  $C_{n.1}$ ,  $C_{n.2}$  and  $R_n$  values should be determined through tuning the load transient response waveforms on an actual board.

$R_{ip}$  and  $C_{ip}$  form an R-C branch in parallel with  $R_i$ , providing a lower impedance path than  $R_i$  at the beginning of  $i_o$  change.  $R_{ip}$  and  $C_{ip}$  do not have any effect at steady state. Through proper selection of  $R_{ip}$  and  $C_{ip}$  values,  $i_{droop}$  can resemble  $i_o$  rather than  $i_L$ , and  $V_o$  will not ring back. The recommended value for  $R_{ip}$  is  $100\Omega$ .  $C_{ip}$  should be determined through tuning the load transient response waveforms on an actual board. The recommended range for  $C_{ip}$  is  $100pF\sim 2000pF$ . However, it should be noted that the  $R_{ip}\text{-}C_{ip}$  branch may distort the  $i_{droop}$  waveform. Instead of being triangular as the real inductor current,  $i_{droop}$  may have sharp spikes, which may adversely affect  $i_{droop}$  average value detection and therefore may affect OCP accuracy. User discretion is advised.

## Resistor Current-Sensing Network

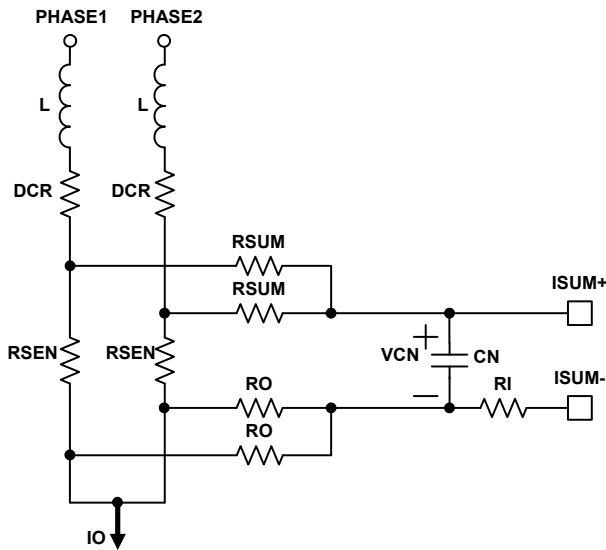


FIGURE 23. RESISTOR CURRENT-SENSING NETWORK

Figure 23 shows the resistor current-sensing network for a 2-phase solution. Each inductor has a series current-sensing resistor  $R_{sen}$ .  $R_{sum}$  and  $R_o$  are connected to the  $R_{sen}$  pads to accurately capture the inductor current information. The  $R_{sum}$  and  $R_o$  resistors are connected to capacitor  $C_n$ .  $R_{sum}$  and  $C_n$  form a filter for noise attenuation. Equations 20 thru 22 give  $V_{Cn}(s)$  expression

$$V_{Cn}(s) = \frac{R_{sen}}{N} \times I_o(s) \times A_{Rsen}(s) \quad (EQ. 20)$$

$$A_{Rsen}(s) = \frac{1}{1 + \frac{s}{\omega_{Rsen}}} \quad (EQ. 21)$$

$$\omega_{Rsen} = \frac{1}{\frac{R_{sum}}{N} \times C_n} \quad (EQ. 22)$$

Transfer function  $A_{Rsen}(s)$  always has unity gain at DC. Current-sensing resistor  $R_{sen}$  value will not have significant variation over-temperature, so there is no need for the NTC network.

The recommended values are  $R_{sum} = 1k\Omega$  and  $C_n = 560pF$ .

## Overcurrent Protection

Refer to Equation 1 on page 15 and Figures 12, 17 and 23; resistor  $R_i$  sets the droop current  $I_{droop}$ . Table 4 shows the internal OCP threshold. It is recommended to design  $I_{droop}$  without using the  $R_{comp}$  resistor.

For example, the OCP threshold is  $40\mu A$  for 2-phase solution. We will design  $I_{droop}$  to be  $34.3\mu A$  at full load, so the OCP trip level is  $1.16x$  of the full load current.

For inductor DCR sensing, Equation 23 gives the DC relationship of  $V_{Cn}(s)$  and  $I_o(s)$ .

$$V_{Cn} = \left( \frac{R_{ntcnet}}{R_{ntcnet} + \frac{R_{sum}}{N}} \times \frac{DCR}{N} \right) \times I_o \quad (EQ. 23)$$

Substitution of Equation 23 into Equation 1 gives Equation 24:

$$I_{droop} = \frac{2}{R_i} \times \frac{R_{ntcnet}}{R_{ntcnet} + \frac{R_{sum}}{N}} \times \frac{DCR}{N} \times I_o \quad (EQ. 24)$$

Therefore:

$$R_i = \frac{2R_{ntcnet} \times DCR \times I_o}{N \times \left( R_{ntcnet} + \frac{R_{sum}}{N} \right) \times I_{droop}} \quad (EQ. 25)$$

Substitution of Equation 15 and application of the OCP condition in Equation 25 gives Equation 26:

$$R_i = \frac{2 \times \left( \frac{R_{ntcs} + R_{ntc}}{R_{ntcs} + R_{ntc} + R_p} \right) \times R_p \times DCR \times I_{o,max}}{N \times \left( \frac{R_{ntcs} + R_{ntc}}{R_{ntcs} + R_{ntc} + R_p} + \frac{R_{sum}}{N} \right) \times I_{droop,max}} \quad (EQ. 26)$$

where  $I_{o,max}$  is the full load current,  $I_{droop,max}$  is the corresponding droop current. For example, given  $N = 2$ ,  $R_{sum} = 3.65k\Omega$ ,  $R_p = 11k\Omega$ ,  $R_{ntcs} = 2.61k\Omega$ ,  $R_{ntc} = 10k\Omega$ ,  $DCR = 0.88m\Omega$ ,  $I_{o,max} = 51A$  and  $I_{droop,max} = 34.3\mu A$ , Equation 26 gives  $R_i = 998\Omega$ .

For resistor sensing, Equation 27 gives the DC relationship of  $V_{Cn}(s)$  and  $I_o(s)$ .

$$V_{Cn} = \frac{R_{sen}}{N} \times I_o \quad (EQ. 27)$$

Substitution of Equation 27 into Equation 1 gives Equation 28:

$$I_{droop} = \frac{2}{R_i} \times \frac{R_{sen}}{N} \times I_o \quad (EQ. 28)$$

Therefore

$$R_i = \frac{2R_{sen} \times I_o}{N \times I_{droop}} \quad (EQ. 29)$$

Substitution of Equation 29 and application of the OCP condition in Equation 25 gives Equation 30:

$$R_i = \frac{2R_{sen} \times I_{o,max}}{N \times I_{droop,max}} \quad (EQ. 30)$$

where  $I_{o\max}$  is the full load current,  $I_{\text{droopmax}}$  is the corresponding droop current. For example, given  $N = 2$ ,  $R_{\text{sen}} = 1\text{m}\Omega$ ,  $I_{o\max} = 51\text{A}$  and  $I_{\text{droopmax}} = 34.3\mu\text{A}$ , Equation 30 gives  $R_i = 1.487\text{k}\Omega$ .

A resistor from COMP to GND can adjust the internal OCP threshold, providing another dimension of fine-tune flexibility. Table 4 shows the detail. It is recommended to scale  $I_{\text{droop}}$  such that the default OCP threshold gives approximately the desired OCP level, then use  $R_{\text{comp}}$  to fine tune the OCP level if necessary.

## Load Line Slope

Refer to Figure 12.

For inductor DCR sensing, substitution of Equation 24 into Equation 2 gives the load line slope expression:

$$LL = \frac{V_{\text{droop}}}{I_o} = \frac{2R_{\text{droop}}}{R_i} \times \frac{R_{\text{ntcnet}}}{R_{\text{ntcnet}} + \frac{R_{\text{sum}}}{N}} \times \frac{\text{DCR}}{N} \quad (\text{EQ. 31})$$

For resistor sensing, substitution of Equation 28 into Equation 2 gives the load line slope expression:

$$LL = \frac{V_{\text{droop}}}{I_o} = \frac{2R_{\text{sen}} \times R_{\text{droop}}}{N \times R_i} \quad (\text{EQ. 32})$$

Substitution of Equation 25 and rewriting Equation 31, or substitution of Equation 29 and rewriting Equation 32 give the same result in Equation 33:

$$R_{\text{droop}} = \frac{I_o}{I_{\text{droop}}} \times LL \quad (\text{EQ. 33})$$

One can use the full load condition to calculate  $R_{\text{droop}}$ . For example, given  $I_{o\max} = 51\text{A}$ ,  $I_{\text{droopmax}} = 34.3\mu\text{A}$  and  $LL = 1.9\text{m}\Omega$ , Equation 33 gives  $R_{\text{droop}} = 2.825\text{k}\Omega$ .

It is recommended to start with the  $R_{\text{droop}}$  value calculated by Equation 33, and fine tune it on the actual board to get accurate load line slope. One should record the output voltage readings at no load and at full load for load line slope calculation. Reading the output voltage at lighter load instead of full load will increase the measurement error.

## Current Monitor

Refer to Equation 13 for the IMON pin current expression.

Refer to Figures 1 and 2, the IMON pin current flows through  $R_{\text{imon}}$ . The voltage across  $R_{\text{imon}}$  is expressed in Equation 34:

$$V_{\text{Rimon}} = 3 \times I_{\text{droop}} \times R_{\text{imon}} \quad (\text{EQ. 34})$$

Rewriting Equation 33 gives Equation 35:

$$I_{\text{droop}} = \frac{I_o}{R_{\text{droop}}} \times LL \quad (\text{EQ. 35})$$

Substitution of Equation 35 into Equation 34 gives Equation 36:

$$V_{\text{Rimon}} = \frac{3I_o \times LL}{R_{\text{droop}}} \times R_{\text{imon}} \quad (\text{EQ. 36})$$

Rewriting Equation 36 and application of full load condition gives Equation 37:

$$R_{\text{imon}} = \frac{V_{\text{Rimon}} \times R_{\text{droop}}}{3I_o \times LL} \quad (\text{EQ. 37})$$

For example, given  $LL = 1.9\text{m}\Omega$ ,  $R_{\text{droop}} = 2.825\text{k}\Omega$ ,  $V_{\text{Rimon}} = 963\text{mV}$  at  $I_{o\max} = 51\text{A}$ , Equation 37 gives  $R_{\text{imon}} = 9.358\text{k}\Omega$ .

A capacitor  $C_{\text{imon}}$  can be paralleled with  $R_{\text{imon}}$  to filter the IMON pin voltage. The  $R_{\text{imon}}C_{\text{imon}}$  time constant is the user's choice. It is recommended to have a time constant long enough such that switching frequency ripples are removed.

## Compensator

Figure 18 shows the desired load transient response waveforms. Figure 24 shows the equivalent circuit of a voltage regulator (VR) with the droop function. A VR is equivalent to a voltage source (= VID) and output impedance  $Z_{\text{out}}(s)$ . If  $Z_{\text{out}}(s)$  is equal to the load line slope LL, i.e., constant output impedance, in the entire frequency range,  $V_o$  will have square response when  $I_o$  has a square change.

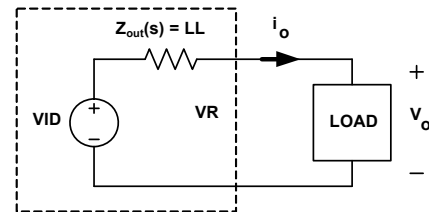


FIGURE 24. VOLTAGE REGULATOR EQUIVALENT CIRCUIT

Intersil provides a Microsoft Excel-based spreadsheet to help design the compensator and the current sensing network, so the VR achieves constant output impedance as a stable system. Figure 27 shows a screenshot of the spreadsheet.

A VR with active droop function is a dual-loop system consisting of a voltage loop and a droop loop which is a current loop. However, neither loop alone is sufficient to describe the entire system. The spreadsheet shows two loop gain transfer functions,  $T1(s)$  and  $T2(s)$ , that describe the entire system. Figure 25 conceptually shows  $T1(s)$  measurement set-up and Figure 26 conceptually shows  $T2(s)$  measurement set-up. The VR senses the inductor current, multiplies it by a gain of the load line slope, then adds it on top of the sensed output voltage and feeds it to the compensator.  $T(1)$  is measured after the summing node, and  $T2(s)$  is measured in the voltage loop before the summing node. The spreadsheet gives both  $T1(s)$  and  $T2(s)$  plots. However, only  $T2(s)$  can be actually measured on an ISL62882 regulator.

$T1(s)$  is the total loop gain of the voltage loop and the droop loop. It always has a higher crossover frequency than  $T2(s)$  and has more meaning of system stability.

$T2(s)$  is the voltage loop gain with closed droop loop. It has more meaning of output voltage response.

Design the compensator to get stable  $T1(s)$  and  $T2(s)$  with sufficient phase margin, and output impedance equal or smaller than the load line slope.

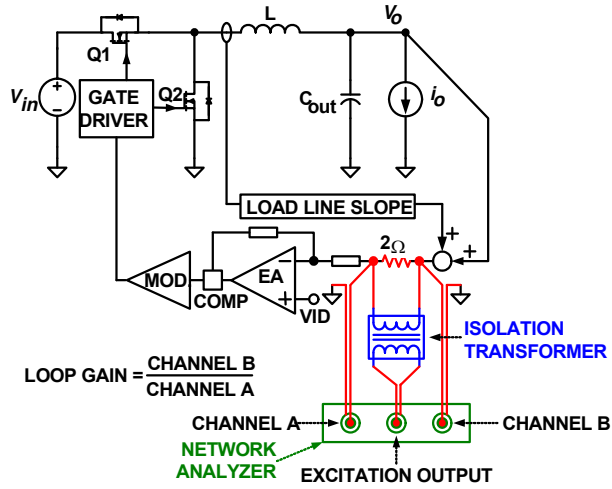


FIGURE 25. LOOP GAIN T1(s) MEASUREMENT SET-UP

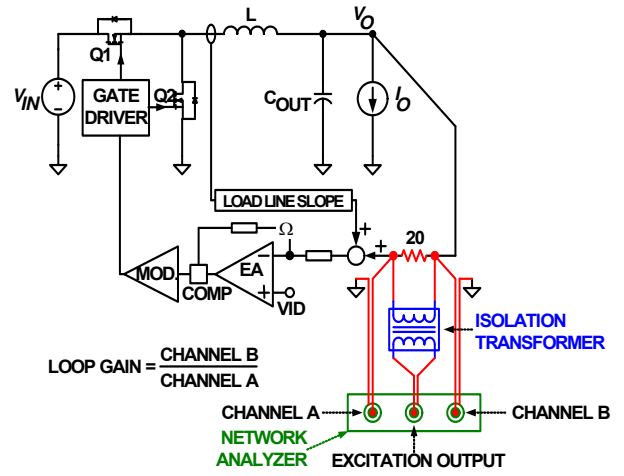


FIGURE 26. LOOP GAIN T2(s) MEASUREMENT SET-UP



**Compensation & Current Sensing Network Design for Intersil Multiphase R^3 Regulators for IMVP-6.5**

Jia Wei, jwei@intersil.com, 919-405-3605

Attention: 1. "Analysis ToolPak" Add-in is required. To turn on, go to Tools--Add-Ins, and check "Analysis ToolPak".

**2. Green cells require user input**

Operation Parameters	
Controller Part Number:	ISL6288x
Phase Number:	2
Vin:	12 volts
Vo:	1.15 volts
Full Load Current:	50 Amps
Estimated Full-Load Efficiency:	87 %
Number of Output Bulk Capacitors:	3
Capacitance of Each Output Bulk Capacitor:	470 uF
ESR of Each Output Bulk Capacitor:	4.5 mΩ
ESL of Each Output Bulk Capacitor:	0.6 nH
Number of Output Ceramic Capacitors:	30
Capacitance of Each Output Ceramic Capacitor:	10 uF
ESR of Each Output Ceramic Capacitor:	3 mΩ
ESL of Each Output Ceramic Capacitor:	3 nH
Switching Frequency:	300 kHz
Inductance Per Phase:	0.36 uH
CPU Socket Resistance:	0.9 mΩ
Desired Load-Line Slope:	1.9 mΩ
Desired ISUM- Pin Current at Full Load:	33.1 uA
(This sets the over-current protection level)	

**Compensator Parameters**

$$A_v(s) = \frac{K \omega_i \cdot \omega_p \cdot \left(1 + \frac{s}{2\pi f_{z1}}\right) \cdot \left(1 + \frac{s}{2\pi f_{z2}}\right)}{s \cdot \left(1 + \frac{s}{2\pi f_{p1}}\right) \cdot \left(1 + \frac{s}{2\pi f_{p2}}\right)}$$

Recommended Value	User-Selected Value
R1 2.870 kΩ	R1 2.87 kΩ
R2 387.248 kΩ	R2 412 kΩ
R3 0.560 kΩ	R3 0.562 kΩ
C1 188.980 pF	C1 150 pF
C2 498.514 pF	C2 390 pF
C3 32.245 pF	C3 32 pF

Use User-Selected Value (Y/N)?  Y  N

**Performance and Stability**

T1 Bandwidth:	190kHz	T2 Bandwidth:	52kHz
T1 Phase Margin:	63.4°	T2 Phase Margin:	94.7°

**Current Sensing Network Parameters**

**Operation Parameters**

Inductor DCR	0.88 mΩ
Rsum	3.65 kΩ
Rntc	10 kΩ
Rntcs	2.61 kΩ
Rp	11 kΩ

**Recommended Value**

Cn	0.294 uF
Ri	1014.245 Ω

**User Selected Value**

Cn	0.294 uF
Ri	1000 Ω

Changing the settings in red requires deep understanding of control loop design

Place the 2nd compensator pole fp2 at: 1.9 xfs (Switching Frequency)

Tune Kwi to get the desired loop gain bandwidth

Tune the compensator gain factor Kwi: 1.15  
(Recommended Kwi range is 0.8~2)

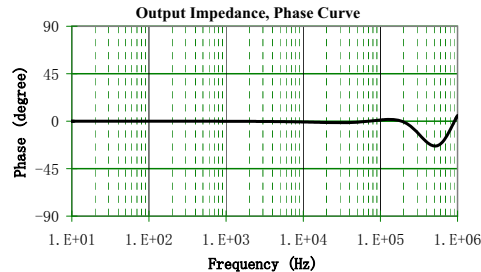
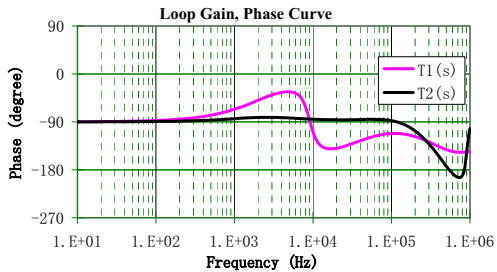
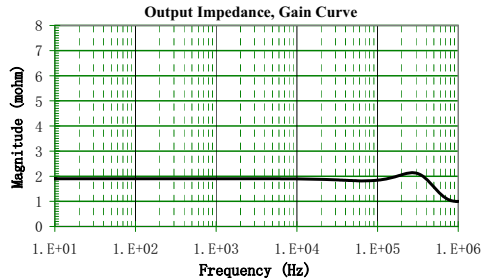
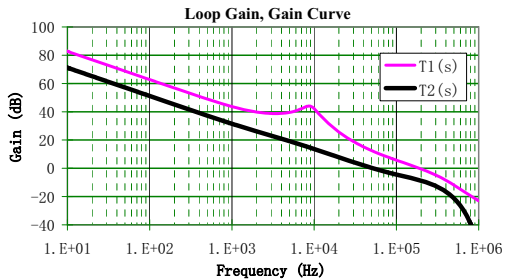


FIGURE 27. SCREENSHOT OF THE COMPENSATOR DESIGN SPREADSHEET

### Optional Slew Rate Compensation Circuit For 1-Tick VID Transition

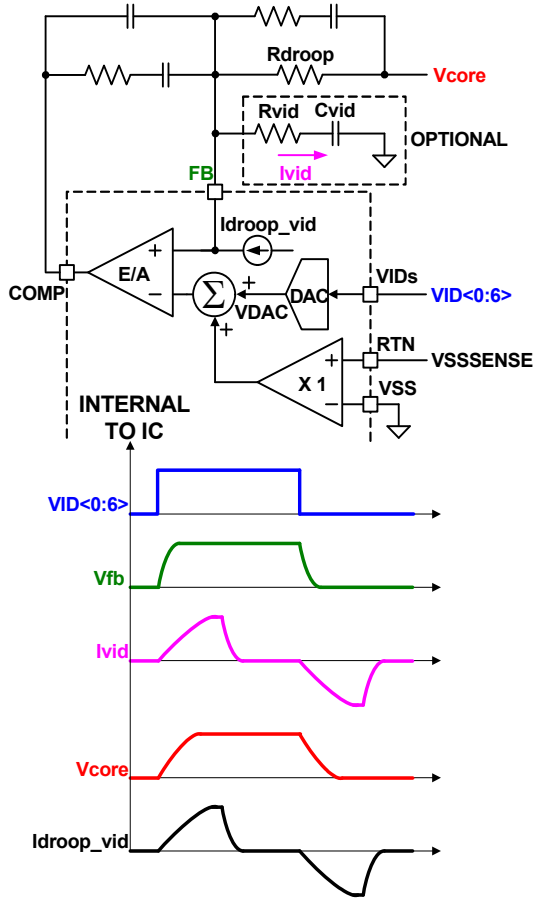


FIGURE 28. OPTIONAL SLEW RATE COMPENSATION CIRCUIT FOR 1-TICK VID TRANSITION

During a large VID transition, the DAC steps through the VIDs at a controlled slew rate. For example, the DAC may change a tick (12.5mV) per 2.5µs per, controlling output voltage V<sub>core</sub> slew rate at 5mV/µs.

Figure 28 shows the waveforms of 1-tick VID transition. During 1-tick VID transition, the DAC output changes at approximately 15mV/µs slew rate, but the DAC cannot step through multiple VIDs to control the slew rate. Instead, the control loop response speed determines V<sub>core</sub> slew rate. Ideally, V<sub>core</sub> will follow the FB pin voltage slew rate. However, the controller senses the inductor current increase during the up transition, as the I<sub>droop\_vid</sub> waveform shows, and will droop the output voltage V<sub>core</sub> accordingly, making V<sub>core</sub> slew rate slow. Similar behavior occurs during the down transition.

To control V<sub>core</sub> slew rate during 1-tick VID transition, one can add the R<sub>vid</sub>-C<sub>vid</sub> branch, whose current I<sub>vid</sub> cancels I<sub>droop\_vid</sub>.

When V<sub>core</sub> increases, the time domain expression of the induced I<sub>droop</sub> change is

$$I_{droop}(t) = \frac{C_{out} \times LL}{R_{droop}} \times \frac{dV_{core}}{dt} \times \left( 1 - e^{-\frac{t}{C_{out} \times LL}} \right) \quad (EQ. 38)$$

where C<sub>out</sub> is the total output capacitance.

In the mean time, the R<sub>vid</sub>-C<sub>vid</sub> branch current I<sub>vid</sub> time domain expression is:

$$I_{vid}(t) = C_{vid} \times \frac{dV_{fb}}{dt} \times \left( 1 - e^{-\frac{t}{R_{vid} \times C_{vid}}} \right) \quad (EQ. 39)$$

It is desired to let I<sub>vid</sub>(t) cancel I<sub>droop\_vid</sub>(t). So there are:

$$C_{vid} \times \frac{dV_{fb}}{dt} = \frac{C_{out} \times LL}{R_{droop}} \times \frac{dV_{core}}{dt} \quad (EQ. 40)$$

and:

$$R_{vid} \times C_{vid} = C_{out} \times LL \quad (EQ. 41)$$

The result is expressed in Equation 42:

$$R_{vid} = R_{droop} \quad (EQ. 42)$$

and:

$$C_{vid} = \frac{C_{out} \times LL}{R_{droop}} \times \frac{dV_{core}/dt}{dV_{fb}/dt} \quad (EQ. 43)$$

For example: given LL = 1.9mΩ, R<sub>droop</sub> = 2.87kΩ, C<sub>out</sub> = 1710µF, dV<sub>core</sub>/dt = 5mV/µs and dV<sub>fb</sub>/dt = 15mV/µs, Equation 42 gives R<sub>vid</sub> = 2.87kΩ and Equation 43 gives C<sub>vid</sub> = 377pF.

It's recommended to select the calculated R<sub>vid</sub> value and start with the calculated C<sub>vid</sub> value and tweak it on the actual board to get the best performance.

During normal transient response, the FB pin voltage is held constant, therefore is virtual ground in small signal sense. The R<sub>vid</sub> - C<sub>vid</sub> network is between the virtual ground and the real ground, and hence has no effect on transient response.

### Voltage Regulator Thermal Throttling

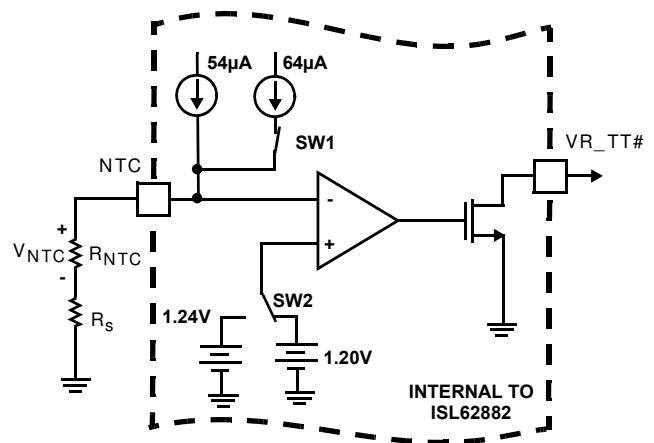


FIGURE 29. CIRCUITRY ASSOCIATED WITH THE THERMAL THROTTLING FEATURE OF THE ISL62882

Figure 29 shows the thermal throttling feature with hysteresis. An NTC network is connected between the NTC pin and GND. At low temperature, SW1 is on and SW2 connects to the 1.20V side. The total current flowing out of the NTC pin is 60μA. The voltage on NTC pin is higher than threshold voltage of 1.20V and the comparator output is low. VR\_TT# is pulled up by the external resistor.

When temperature increases, the NTC thermistor resistance decreases so the NTC pin voltage drops. When the NTC pin voltage drops below 1.20V, the comparator changes polarity and turns SW1 off and throws SW2 to 1.24V. This pulls VR\_TT# low and sends the signal to start thermal throttle. There is a 6μA current reduction on NTC pin and 40mV voltage increase on threshold voltage of the comparator in this state. The VR\_TT# signal will be used to change the CPU operation and decrease the power consumption. When the temperature drops down, the NTC thermistor voltage will go up. If NTC voltage increases to above 1.24V, the comparator will flip back. The external resistance difference in these two conditions is shown in Equation 44:

$$\frac{1.24V}{54\mu A} - \frac{1.20V}{60\mu A} = 2.96k \quad (\text{EQ. 44})$$

One needs to properly select the NTC thermistor value such that the required temperature hysteresis correlates to 2.96kΩ resistance change. A regular resistor may need to be in series with the NTC thermistor to meet the threshold voltage values.

For example, given Panasonic NTC thermistor with B = 4700, the resistance will drop to 0.03322 of its nominal at +105°C, and drop to 0.03956 of its nominal at +100°C. If the required temperature hysteresis is +105°C to +100°C, the required resistance of NTC will be as shown in Equation 45:

$$\frac{2.96k\Omega}{(0.03956 - 0.03322)} = 467k\Omega \quad (\text{EQ. 45})$$

Therefore, a larger value thermistor such as 470k NTC should be used.

At +105°C, 470kΩ NTC resistance becomes  $(0.03322 \times 470k\Omega) = 15.6k\Omega$ . With 60μA on the NTC pin, the voltage is only  $(15.6k\Omega \times 60\mu A) = 0.937V$ . This value is much lower than the threshold voltage of 1.20V. Therefore, a regular resistor needs to be in series with the NTC. The required resistance can be calculated by Equation 46:

$$\frac{1.20V}{60\mu A} - 15.6k\Omega = 4.4k\Omega \quad (\text{EQ. 46})$$

4.42k is a standard resistor value. Therefore, the NTC branch should have a 470k NTC and 4.42k resistor in series. The part number for the NTC thermistor is ERTJOEV474J. It is a 0402 package. NTC thermistor will be placed in the hot spot of the board.

## Current Balancing

Refer to Figures 1 and 2. The ISL62882 achieves current balancing through matching the ISEN pin voltages.  $R_S$  and  $C_S$  form filters to remove the switching ripple of the phase node voltages. It is recommended to use rather long  $R_S C_S$  time constant such that the ISEN voltages have minimal ripple and represent the DC current flowing through the inductors. Recommended values are  $R_S = 10k\Omega$  and  $C_S = 0.22\mu F$ .

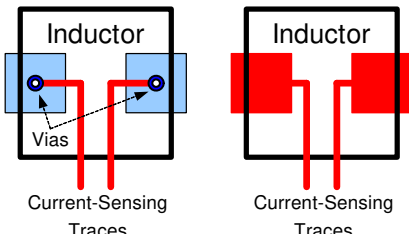
## Layout Guidelines

Table 6 shows the layout considerations. The designators refer to the reference design shown in Figure 31.

TABLE 6. LAYOUT CONSIDERATION

PIN	NAME	LAYOUT CONSIDERATION
EP	GND	Create analog ground plane underneath the controller and the analog signal processing components. Don't let the power ground plane overlap with the analog ground plane. Avoid noisy planes/traces (e.g.: phase node) from crossing over/overlapping with the analog plane.
1	PGOOD	No special consideration
2	PSI#	No special consideration
3	RBIAS	Place the $R_{BIAS}$ resistor (R16) in general proximity of the controller. Low impedance connection to the analog ground plane.
4	VR_TT#	No special consideration
5	NTC	The NTC thermistor (R9) needs to be placed close to the thermal source that is monitor to determine thermal throttling. Usually it's placed close to phase-1 high-side MOSFET.
6	VW	Place the capacitor (C4) across VW and COMP in close proximity of the controller
7	COMP	Place the compensator components (C3, C5, C6 R7, R11, R10 and C11) in general proximity of the controller.
8	FB	
9	FB2	
10	ISEN2	A capacitor (C9) decouples it to VSUM-. Place it in general proximity of the controller.
11	ISEN1	A capacitor (C10) decouples it to VSUM-. Place it in general proximity of the controller.
12	VSEN	Place the VSEN/RTN filter (C12, C13) in close proximity of the controller for good decoupling.
13	RTN	

**TABLE 6. LAYOUT CONSIDERATION (Continued)**

PIN	NAME	LAYOUT CONSIDERATION
14	ISUM-	Place the current sensing circuit in general proximity of the controller.
15	ISUM+	Place C82 very close to the controller. Place NTC thermistors R42 next to phase-1 inductor (L1) so it senses the inductor temperature correctly. Each phase of the power stage sends a pair of VSUM+ and VSUM- signals to the controller. Run these two signals traces in parallel fashion with decent width (>20mil). <b>IMPORTANT:</b> Sense the inductor current by routing the sensing circuit to the inductor pads. Route R63 and R71 to the phase-1 side pad of inductor L1. Route R88 to the output side pad of inductor L1. Route R65 and R72 to the phase-2 side pad of inductor L2. Route R90 to the output side pad of inductor L2. If possible, route the traces on a different layer from the inductor pad layer and use vias to connect the traces to the center of the pads. If no via is allowed on the pad, consider routing the traces into the pads from the inside of the inductor. The following drawings show the two preferred ways of routing current sensing traces.
		
16	VDD	A capacitor (C16) decouples it to GND. Place it in close proximity of the controller.
17	VIN	A capacitor (C17) decouples it to GND. Place it in close proximity of the controller.
18	IMON	Place the filter capacitor (C21) close to the CPU.
19	BOOT1	Use decent wide trace (>30mil). Avoid any sensitive analog signal trace from crossing over or getting close.
20	UGATE1	Run these two traces in parallel fashion with decent width (>30mil). Avoid any sensitive analog signal trace from crossing over or getting close.
21	PHASE1	Recommend routing PHASE1 trace to the phase-1 high-side MOSFET (Q2 and Q8) source pins instead of general phase-1 node copper.
22	VSSP1	Run these two traces in parallel fashion with decent width (>30mil). Avoid any sensitive analog signal trace from crossing over or getting close.
23	LGATE1a	Recommend routing VSSP1 to the phase-1 low-side MOSFET (Q3 and Q9) source pins instead of general power ground plane for better performance.
24	LGATE1b	
25	VCCP	A capacitor (C22) decouples it to GND. Place it in close proximity of the controller.

**TABLE 6. LAYOUT CONSIDERATION (Continued)**

PIN	NAME	LAYOUT CONSIDERATION
26	LGATE2	Run these two traces in parallel fashion with decent width (>30mil). Avoid any sensitive analog signal trace from crossing over or getting close.
27	VSSP2	Recommend routing VSSP2 to the phase-2 low-side MOSFET (Q5 and Q1) source pins instead of general power ground plane for better performance.
28	PHASE2	Run these two traces in parallel fashion with decent width (>30mil). Avoid any sensitive analog signal trace from crossing over or getting close.
29	UGATE2	Recommend routing PHASE2 trace to the phase-2 high-side MOSFET (Q4 and Q10) source pins instead of general phase-2 node copper.
30	BOOT2	Use decent wide trace (>30mil). Avoid any sensitive analog signal trace from crossing over or getting close.
31~37	VID0~6	No special consideration.
38	VR_ON	No special consideration.
39	DPRSLPVR	No special consideration.
40	CLK_EN#	No special consideration.
Other	Phase Node	Minimize phase node copper area. Don't let the phase node copper overlap with/getting close to other sensitive traces. Cut the power ground plane to avoid overlapping with phase node copper.
Other		Minimize the loop consisting of input capacitor, high-side MOSFETs and low-side MOSFETs (e.g., C27, C33, Q2, Q8, Q3 and Q9).

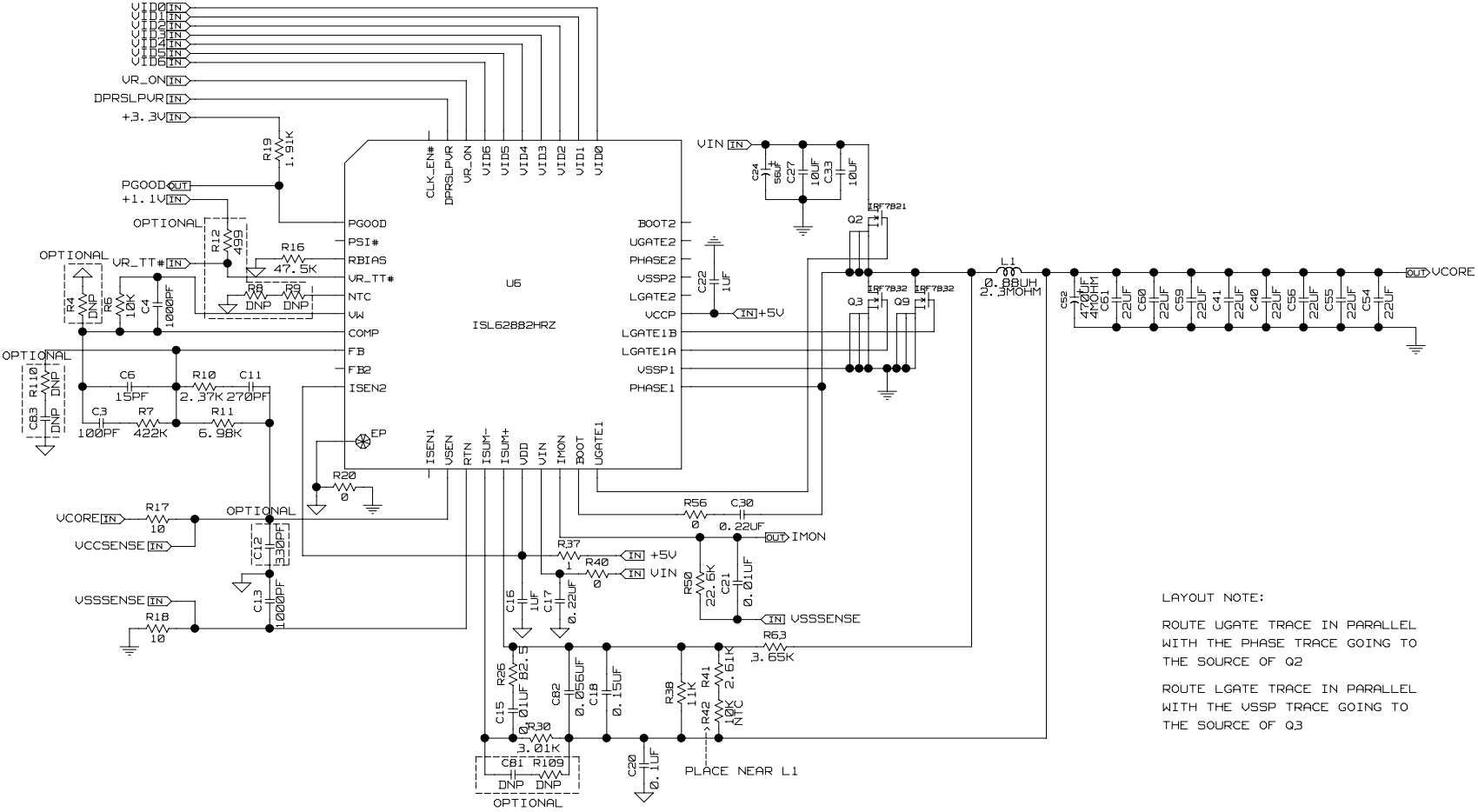
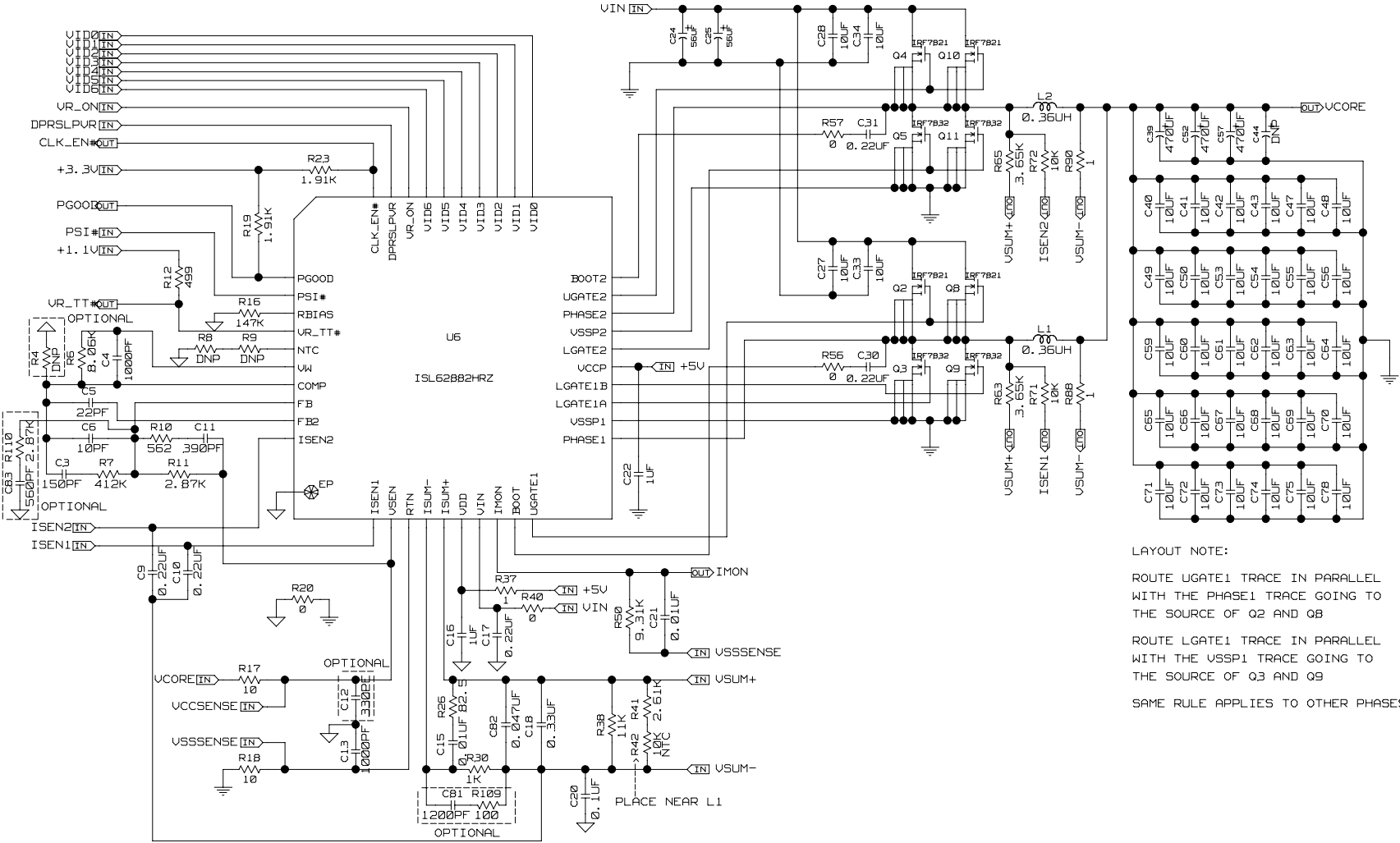


FIGURE 30. 1-PHASE GPU APPLICATION REFERENCE DESIGN

LAYOUT NOTE:  
 ROUTE UGATE TRACE IN PARALLEL WITH THE PHASE TRACE GOING TO THE SOURCE OF Q2  
 ROUTE LGATE TRACE IN PARALLEL WITH THE VSSP TRACE GOING TO THE SOURCE OF Q3



LAYOUT NOTE:  
 ROUTE UGATE1 TRACE IN PARALLEL WITH THE PHASE1 TRACE GOING TO THE SOURCE OF Q2 AND Q8  
 ROUTE LGATE1 TRACE IN PARALLEL WITH THE VSSP1 TRACE GOING TO THE SOURCE OF Q3 AND Q9  
 SAME RULE APPLIES TO OTHER PHASES

FIGURE 31. 2-PHASE CPU APPLICATION REFERENCE DESIGN

## 1-Phase GPU Application Reference Design Bill of Materials

QTY	REFERENCE	VALUE	DESCRIPTION	MANUFACTURER	PART NUMBER	PACKAGE
1	C11	270pF	Multilayer Cap, 16V, 10%	GENERIC	H1045-00271-16V10	SM0603
1	C12	330pF	Multilayer Cap, 16V, 10%	GENERIC	H1045-00331-16V10	SM0603
1	C13	1000pF	Multilayer Cap, 16V, 10%	GENERIC	H1045-00102-16V10	SM0603
1	C15	0.01μF	Multilayer Cap, 16V, 10%	GENERIC	H1045-00103-16V10	SM0603
2	C16,C22	1μF	Multilayer Cap, 16V, 20%	GENERIC	H1045-00105-16V20	SM0603
1	C18	0.15μF	Multilayer Cap, 16V, 10%	GENERIC	H1045-00154-16V10	SM0603
1	C20	0.1μF	Multilayer Cap, 16V, 10%	GENERIC	H1045-00104-16V10	SM0603
3	C17, C21, C30	0.22μF	Multilayer Cap, 25V, 10%	GENERIC	H1045-00224-25V10	SM0603
1	C24	56μF	Radial SP Series Cap, 25V, 20%	SANYO	25SP56M	CASE-CC
2	C27,C33	10μF	Multilayer Cap, 25V, 20%	GENERIC	H1065-00106-25V20	SM1206
1	C3	100pF	Multilayer Cap, 16V, 10%	GENERIC	H1045-00101-16V10	SM0603
1	C52	470μF	SPCAP, 2V, 4MΩ POLYMER CAP, 2.5V, 4.5MΩ	PANASONIC KEMET	EEXSX0D471E4 T520V477M2R5A(1)E4R5-6666	
1	C4	1000pF	Multilayer Cap, 16V, 10%	GENERIC	H1045-00102-16V10	SM0603
8	C40, C41, C54-C56, C59-C61	10μF	Multilayer Cap, 6.3V, 20%	MURATA PANASONIC TDK	GRM21BR61C106KE15L ECJ2FB0J106K C2012X5R0J106K	SM0805
1	C6	15pF	Multilayer Cap, 16V, 10%	GENERIC	H1045-00150-16V10	SM0603
1	C82	0.056μF	Multilayer Cap, 16V, 10%	GENERIC	H1045-00563-16V10	SM0603
0	C81, C83	DNP				
1	L1	0.88μH	Inductor, Inductance 20%, DCR 7%	NEC-TOKIN	MPC1040LR88	10mmx10mm
1	Q2		N-Channel Power MOSFET	IR	IRF7821	PWRPAKS08
2	Q3, Q9		N-Channel Power MOSFET	IR	IRF7832	PWRPAKS08
1	R10	2.37k	Thick Film Chip Resistor, 1%	GENERIC	H2511-02371-1/16W1	SM0603
1	R11	6.98k	Thick Film Chip Resistor, 1%	GENERIC	H2511-06981-1/16W1	SM0603
1	R16	47.5k	Thick Film Chip Resistor, 1%	GENERIC	H2511-04752-1/16W1	SM0603
2	R17, R18	10	Thick Film Chip Resistor, 1%	GENERIC	H2511-00100-1/16W1	SM0603
1	R19	1.91k	Thick Film Chip Resistor, 1%	GENERIC	H2511-01911-1/16W1	SM0603
1	R26	82.5	Thick Film Chip Resistor, 1%	GENERIC	H2511-082R5-1/16W1	SM0603
3	R20, R40, R56	0	Thick Film Chip Resistor, 1%	GENERIC	H2511-00R00-1/16W1	SM0603
1	R30	3.01k	Thick Film Chip Resistor, 1%	GENERIC	H2511-03011-1/16W1	SM0603
1	R37	1	Thick Film Chip Resistor, 1%	GENERIC	H2511-01R00-1/16W1	SM0603
1	R38	11k	Thick Film Chip Resistor, 1%	GENERIC	H2511-01102-1/16W1	SM0603
1	R41	2.61k	Thick Film Chip Resistor, 1%	GENERIC	H2511-02611-1/16W1	SM0603
1	R42	10k NTC	Thermistor, 10k NTC	PANASONIC	ERT-J1VR103J	SM0603
1	R50	22.6k	Thick Film Chip Resistor, 1%	GENERIC	H2511-02262-1/16W1	SM0603

**1-Phase GPU Application Reference Design Bill of Materials** (Continued)

QTY	REFERENCE	VALUE	DESCRIPTION	MANUFACTURER	PART NUMBER	PACKAGE
1	R6	10k	Thick Film Chip Resistor, 1%	GENERIC	H2511-01002-1/16W1	SM0603
1	R63	3.65k	Thick Film Chip Resistor, 1%	GENERIC	H2511-03651-1/16W1	SM0805
1	R7	412k	Thick Film Chip Resistor, 1%	GENERIC	H2511-04123-1/16W1	SM0603
0	R109, R110, R4, R8, R9	DNP				
1	U6		IMVP-6.5 PWM Controller	INTERSIL	ISL62882HRTZ	QFN-40

**2-Phase CPU Application Reference Design Bill of Materials**

QTY	REFERENCE	VALUE	DESCRIPTION	MANUFACTURER	PART NUMBER	PACKAGE
1	C11	390pF	Multilayer Cap, 16V, 10%	GENERIC	H1045-00391-16V10	SM0603
1	C12	330pF	Multilayer Cap, 16V, 10%	GENERIC	H1045-00331-16V10	SM0603
1	C13	1000pF	Multilayer Cap, 16V, 10%	GENERIC	H1045-00102-16V10	SM0603
2	C15, C21	0.01μF	Multilayer Cap, 16V, 10%	GENERIC	H1045-00103-16V10	SM0603
2	C16, C22	1μF	Multilayer Cap, 16V, 20%	GENERIC	H1045-00105-16V20	SM0603
1	C18	0.33μF	Multilayer Cap, 16V, 10%	GENERIC	H1045-00334-16V10	SM0603
1	C20	0.1μF	Multilayer Cap, 16V, 10%	GENERIC	H1045-00104-16V10	SM0603
5	C9, C10, C17, C30, C31	0.22μF	Multilayer Cap, 25V, 10%	GENERIC	H1045-00224-25V10	SM0603
2	C24, C25	56μF	Radial SP Series Cap, 25V, 20%	SANYO	25SP56M	CASE-CC
4	C27, C28, C33, C34	10μF	Multilayer Cap, 25V, 20%	GENERIC	H1065-00106-25V20	SM1206
1	C3	150pF	Multilayer Cap, 16V, 10%	GENERIC	H1045-00151-16V10	SM0603
3	C39, C52, C57	470μF	SPCAP, 2V, 4MΩ POLYMER CAP, 2.5V, 4.5MΩ	PANASONIC KEMET	EEXSX0D471E4 T520V477M2R5A(1)E4R5-6666	
1	C4	1000pF	Multilayer Cap, 16V, 10%	GENERIC	H1045-00102-16V10	SM0603
30	C40-C43, C47-C50, C53-C56, C59-C75, C78	10μF	Multilayer Cap, 6.3V, 20%	MURATA PANASONIC TDK	GRM21BR61C106KE15L ECJ2FB0J106K C2012X5R0J106K	SM0805
1	C5	22pF	Multilayer Cap, 16V, 10%	GENERIC	H1045-00220-16V10	SM0603
1	C6	10pF	Multilayer Cap, 16V, 10%	GENERIC	H1045-00100-16V10	SM0603
1	C81	1200pF	Multilayer Cap, 16V, 10%	GENERIC	H1045-00122-16V10	SM0603
1	C82	0.047μF	Multilayer Cap, 16V, 10%	GENERIC	H1045-00473-16V10	SM0603
1	C83	560pF	Multilayer Cap, 16V, 10%	GENERIC	H1045-00561-16V10	SM0603
2	L1, L2	0.36μH	Inductor, Inductance 20%, DCR 7%	NEC-TOKIN PANASONIC	MPCH1040LR36 ETQP4LR36AFC	10mmx10mm
4	Q2, Q4, Q8, Q10		N-Channel Power MOSFET	IR	IRF7821	PWRPAKS08
4	Q3, Q5, Q9, Q11		N-Channel Power MOSFET	IR	IRF7832	PWRPAKS08
1	R10	562	Thick Film Chip Resistor, 1%	GENERIC	H2511-05620-1/16W1	SM0603
1	R109	100	Thick Film Chip Resistor, 1%	GENERIC	H2511-01000-1/16W1	SM0603
1	R11	2.87k	Thick Film Chip Resistor, 1%	GENERIC	H2511-02871-1/16W1	SM0603
1	R110	2.87k	Thick Film Chip Resistor, 1%	GENERIC	H2511-02871-1/16W1	SM0603
1	R12	499	Thick Film Chip Resistor, 1%	GENERIC	H2511-04990-1/16W1	SM0603
1	R16	147k	Thick Film Chip Resistor, 1%	GENERIC	H2511-01473-1/16W1	SM0603



## 2-Phase CPU Application Reference Design Bill of Materials (Continued)

QTY	REFERENCE	VALUE	DESCRIPTION	MANUFACTURER	PART NUMBER	PACKAGE
2	R17, R18	10	Thick Film Chip Resistor, 1%	GENERIC	H2511-00100-1/16W1	SM0603
3	R19, R71, R72	10k	Thick Film Chip Resistor, 1%	GENERIC	H2511-01002-1/16W1	SM0603
1	R23	1.91k	Thick Film Chip Resistor, 1%	GENERIC	H2511-01911-1/16W1	SM0603
1	R26	82.5	Thick Film Chip Resistor, 1%	GENERIC	H2511-082R5-1/16W1	SM0603
4	R20, R40, R56, R57	0	Thick Film Chip Resistor, 1%	GENERIC	H2511-00R00-1/16W1	SM0603
1	R30	1k	Thick Film Chip Resistor, 1%	GENERIC	H2511-01001-1/16W1	SM0603
3	R37, R88, R90	1	Thick Film Chip Resistor, 1%	GENERIC	H2511-01R00-1/16W1	SM0603
1	R38	11k	Thick Film Chip Resistor, 1%	GENERIC	H2511-01102-1/16W1	SM0603
1	R4	DNP				
1	R41	2.61k	Thick Film Chip Resistor, 1%	GENERIC	H2511-02611-1/16W1	SM0603
1	R42	10k NTC	Thermistor, 10k NTC	PANASONIC	ERT-J1VR103J	SM0603
1	R50	9.31k	Thick Film Chip Resistor, 1%	GENERIC	H2511-09311-1/16W1	SM0603
1	R6	8.06k	Thick Film Chip Resistor, 1%	GENERIC	H2511-08061-1/16W1	SM0603
2	R63, R65	3.65k	Thick Film Chip Resistor, 1%	GENERIC	H2511-03651-1/16W1	SM0805
2	R8, R9	DNP				
1	R7	412k	Thick Film Chip Resistor, 1%	GENERIC	H2511-04123-1/16W1	SM0603
1	U6		IMVP-6.5 PWM Controller	INTERSIL	ISL62882HRTZ	QFN-40

# Typical Performance

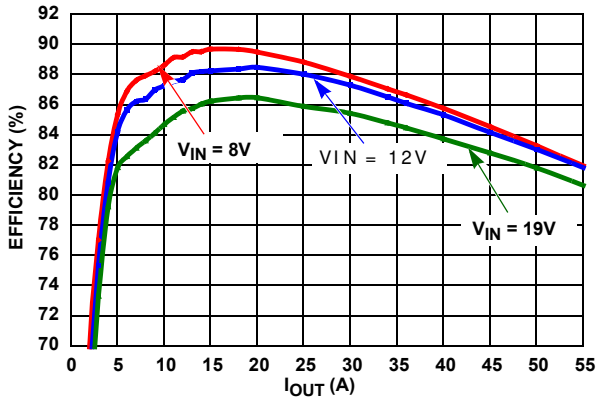


FIGURE 32. 2-PHASE CCM EFFICIENCY, VID = 1.075V, VIN1 = 8V, VIN2 = 12.6V AND VIN3 = 19V

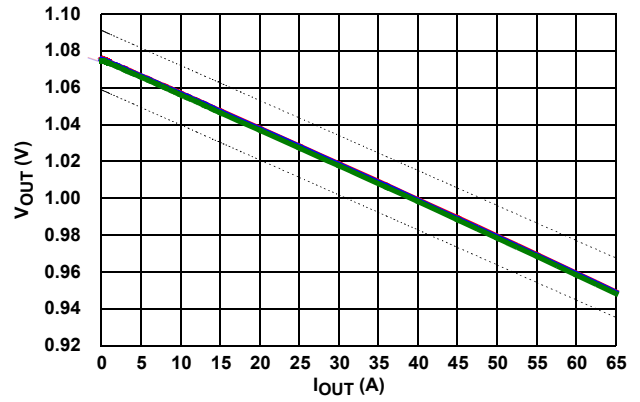


FIGURE 33. 2-PHASE CCM LOAD LINE, VID = 1.075V, VIN1 = 8V, VIN2 = 12.6V AND VIN3 = 19V

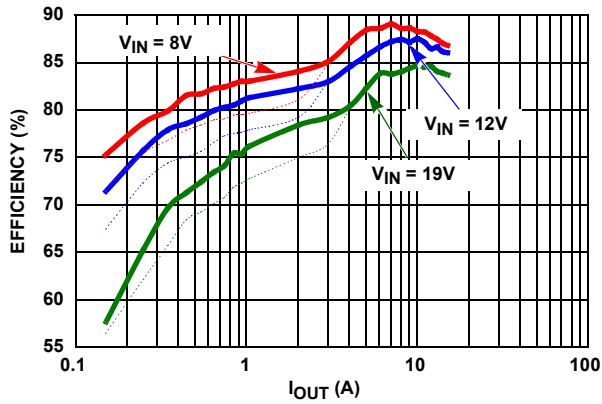


FIGURE 34. 1-PHASE DEM EFFICIENCY, VID = 0.875V, DPRSLPVR IS ASSERTED FOR IOUT < 3A, VIN1 = 8V, VIN2 = 12.6V AND VIN3 = 19V. SOLID LINES: ISL62882 EFFICIENCY, DOTTED LINES: WOULD-BE EFFICIENCY IF LGATE1b WAS NOT TURNED OFF IN DPRSLPVR MODE

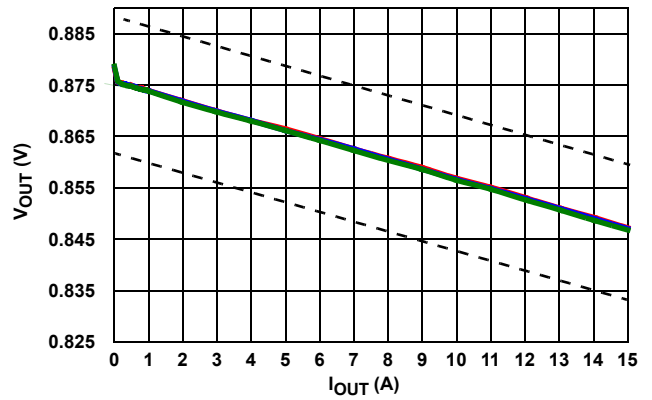


FIGURE 35. 1-PHASE DEM LOAD LINE, VID = 0.875V, DPRSLPVR IS ASSERTED FOR IOUT < 3A VIN1 = 8V, VIN2 = 12.6V AND VIN3 = 19V

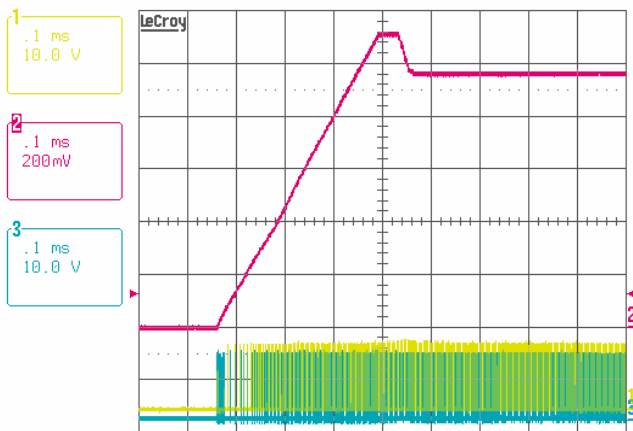


FIGURE 36. 2-PHASE CPU MODE SOFT-START, VIN = 19V, IO = 0A, VID = 0.95V, Ch1: PHASE1, Ch2: V0, Ch3: PHASE2

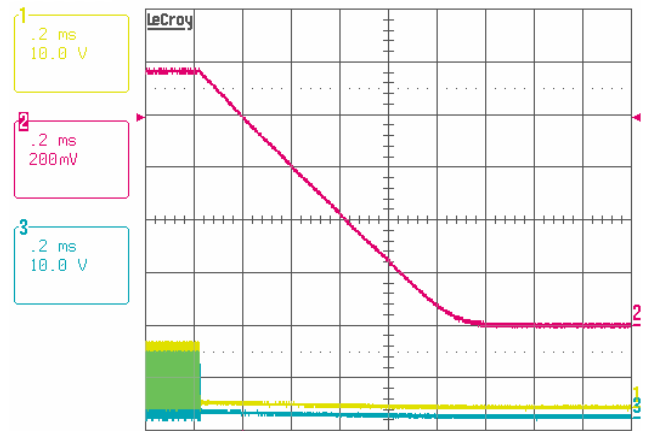
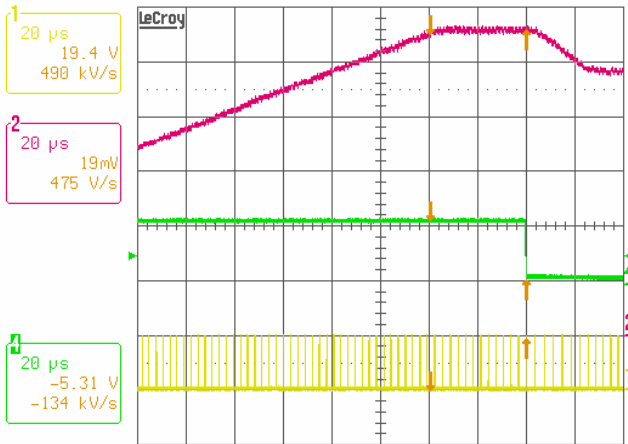
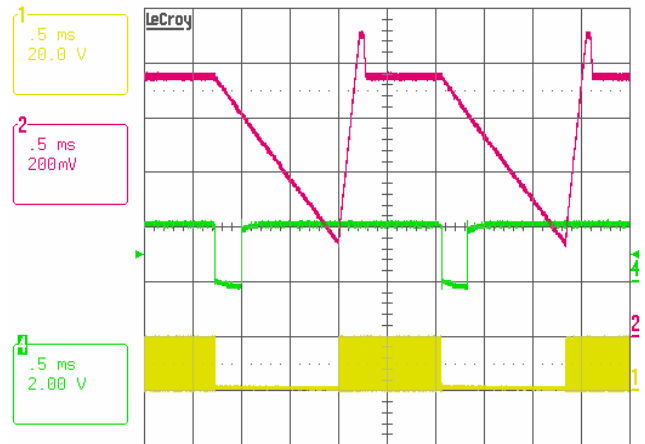


FIGURE 37. 2-PHASE CPU MODESHUT DOWN, VIN = 19V, IO = 1A, VID = 0.95V, Ch1: PHASE1, Ch2: V0, Ch3: PHASE2

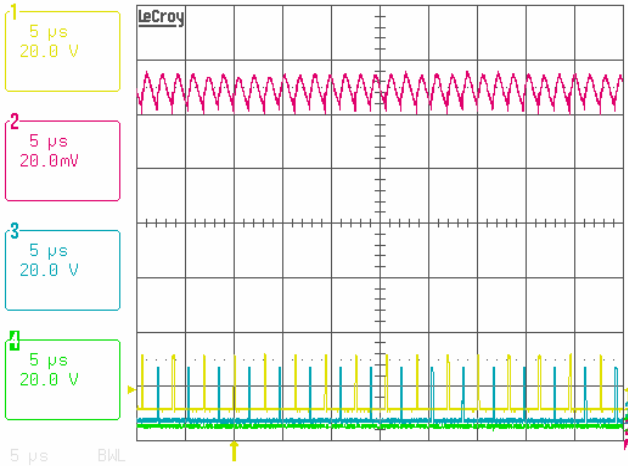
## Typical Performance (Continued)



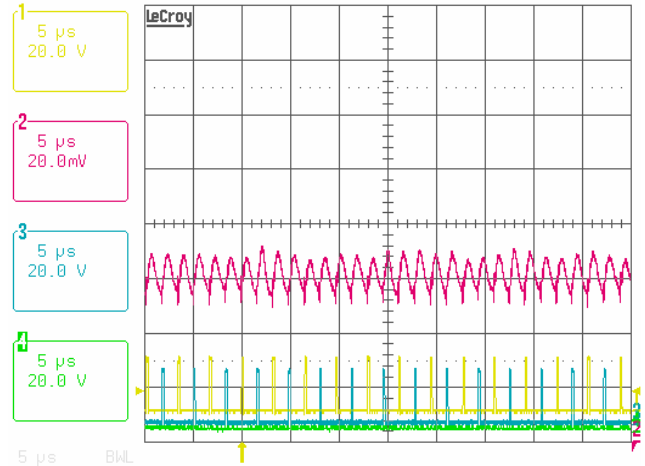
**FIGURE 38. 2-PHASE CPU MODE CLK\_EN# DELAY,  $V_{IN} = 19V$ ,  $I_O = 2A$ ,  $V_{ID} = 1.5V$ , Ch1: PHASE1, Ch2:  $V_O$ , Ch4: CLK\_EN#**



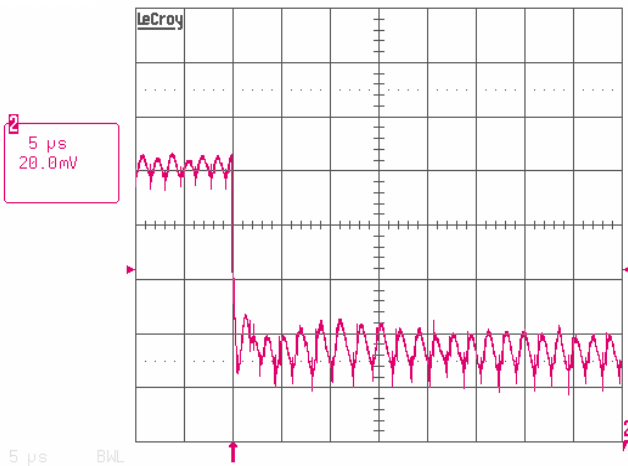
**FIGURE 39. 2-PHASE CPU MODE PRE-CHARGED START UP,  $V_{IN} = 19V$ ,  $V_{ID} = 0.95V$ , Ch1: PHASE1, Ch2:  $V_O$ , Ch4: VR\_ON**



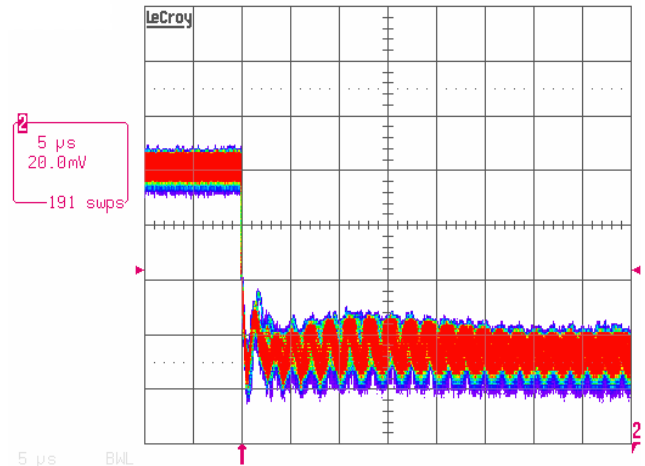
**FIGURE 40. STEADY STATE,  $V_{IN} = 19V$ ,  $I_O = 0A$ ,  $V_{ID} = 1.075V$ , Ch1: PHASE1, Ch2:  $V_O$ , Ch3: PHASE2**



**FIGURE 41. STEADY STATE,  $V_{IN} = 19V$ ,  $I_O = 35A$ ,  $V_{ID} = 1.075V$ , Ch1: PHASE1, Ch2:  $V_O$ , Ch3: PHASE2**

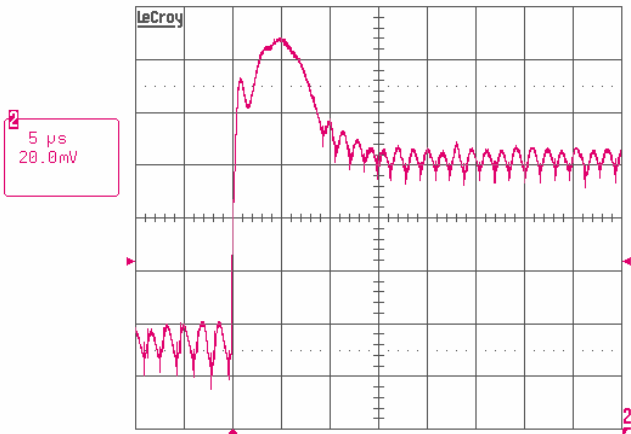


**FIGURE 42. LOAD TRANSIENT RESPONSE WITH OVERSHOOT REDUCTION FUNCTION DISABLED,  $V_{IN} = 19V$ ,  $V_{ID} = 1.075V$ ,  $I_O = 15A/50A$ ,  $di/dt = \text{“FASTEST”}$**

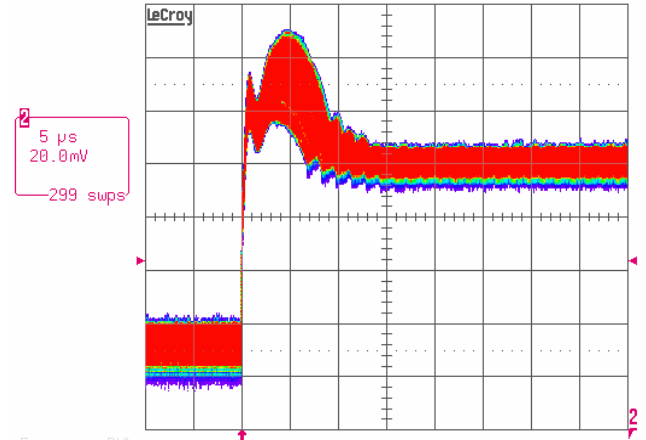


**FIGURE 43. LOAD TRANSIENT RESPONSE WITH OVERSHOOT REDUCTION FUNCTION DISABLED,  $V_{IN} = 19V$ ,  $V_{ID} = 1.075V$ ,  $I_O = 15A/50A$ ,  $di/dt = \text{“FASTEST”}$**

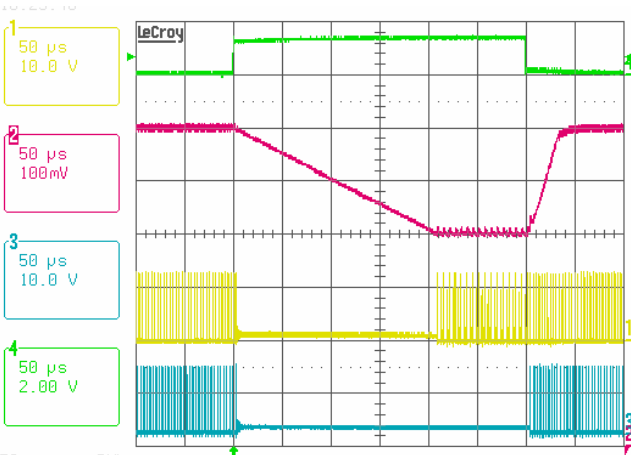
# Typical Performance (Continued)



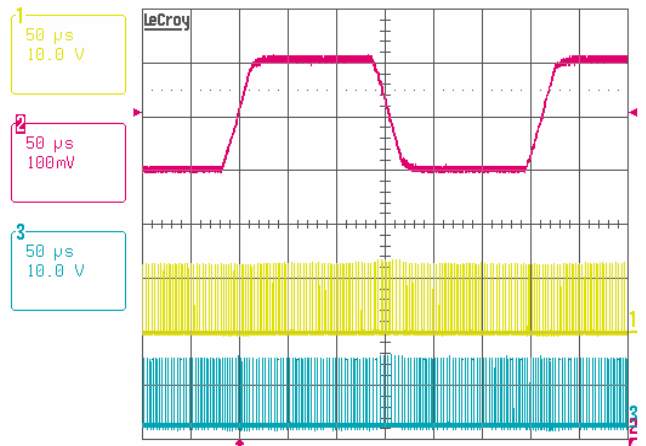
**FIGURE 44. LOAD TRANSIENT RESPONSE WITH OVERSHOOT REDUCTION FUNCTION DISABLED,  $V_{IN} = 19V$ ,  $VID = 1.075V$ ,  $I_O = 15A/50A$ ,  $di/dt = \text{“FASTEST”}$**



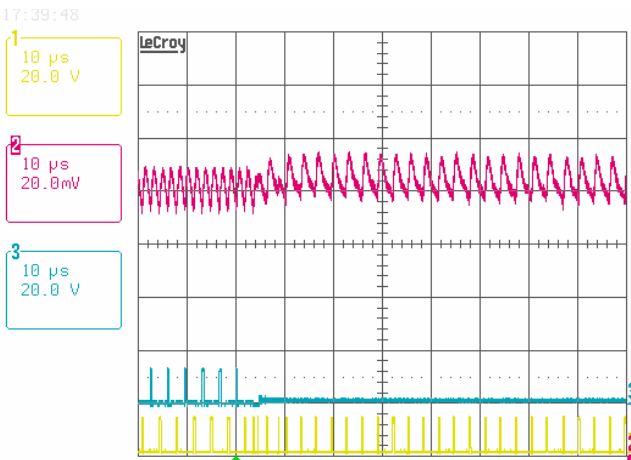
**FIGURE 45. LOAD TRANSIENT RESPONSE WITH OVERSHOOT REDUCTION FUNCTION DISABLED,  $V_{IN} = 19V$ ,  $VID = 1.075V$ ,  $I_O = 15A/50A$ ,  $di/dt = \text{“FASTEST”}$**



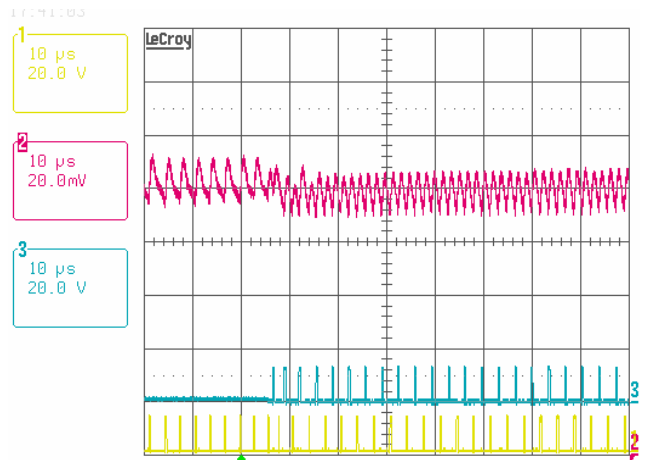
**FIGURE 46. 2-PHASE CPU MODE DEEPER SLEEP MODE ENTRY/EXIT,  $I_O = 1.5A$ , HFM  $VID = 1.075V$ , LFM  $VID = 0.875V$ , DEEPER SLEEP  $VID = 0.875V$ , Ch1: PHASE1, Ch2:  $V_O$ , Ch3: PHASE2, CH4: DPRSLPVR**



**FIGURE 47. 2-PHASE CPU MODE VID ON THE FLY, 1.075V/0.875V, 2-PHASE CONFIGURATION,  $PSI\# = 1$ ,  $DPRSLPVR = 0$ , Ch1: PHASE1, Ch2:  $V_O$ , Ch3: PHASE2**

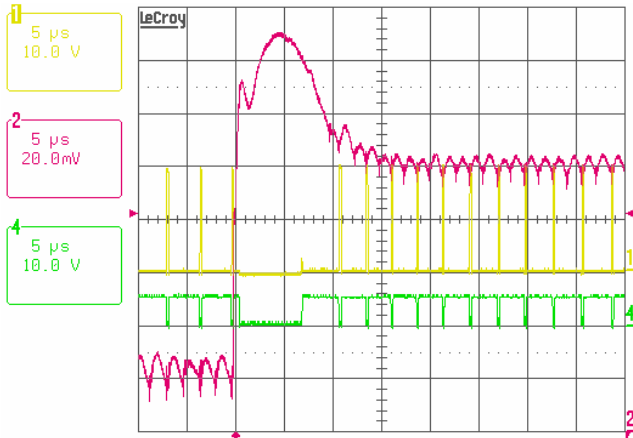


**FIGURE 48. PHASE ADDING ( $PSI\#$  TOGGLE),  $I_O = 15A$ ,  $VID = 1.075V$ , Ch1: PHASE1, Ch2:  $V_O$ , Ch3: PHASE2, Ch4: N/A**

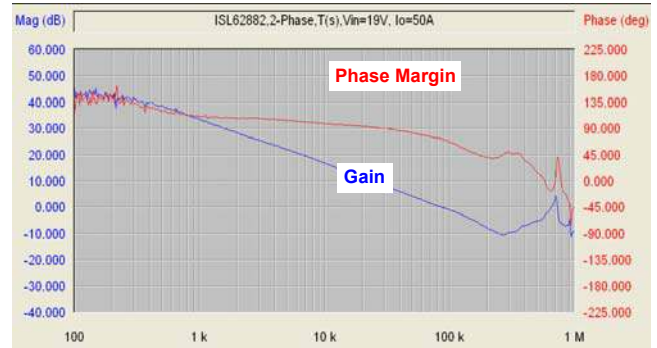


**FIGURE 49. PHASE DROPPING ( $PSI\#$  TOGGLE),  $I_O = 15A$ ,  $VID = 1.075V$ , Ch1: PHASE1, Ch2:  $V_O$ , Ch3: PHASE2, Ch4: N/A**

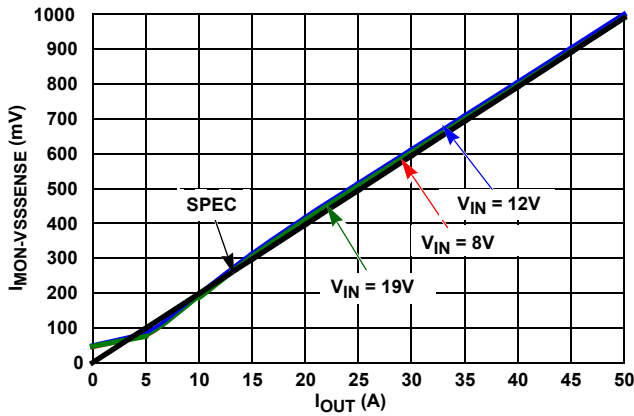
**Typical Performance** (Continued)



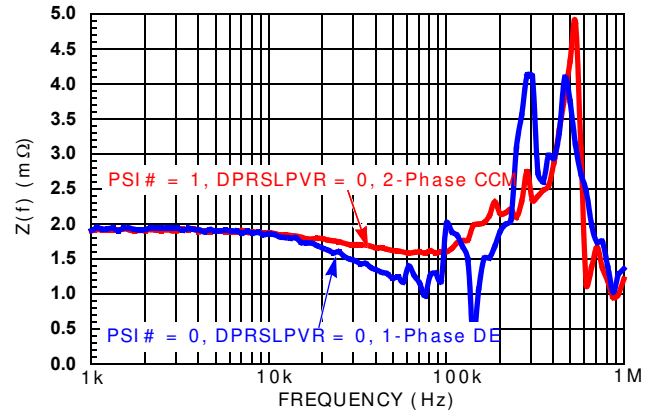
**FIGURE 50. TRANSIENT RESPONSE WITH OVERSHOOT REDUCTION FUNCTION ENABLED,  $V_{IN} = 19V$ ,  $V_{ID} = 0.95V$ ,  $I_O = 12A/51A$ ,  $di/dt = \text{“FASTEST”}$ , Ch1: PHASE1, Ch2:  $V_O$ , Ch3: N/A, Ch4: LGATE1**



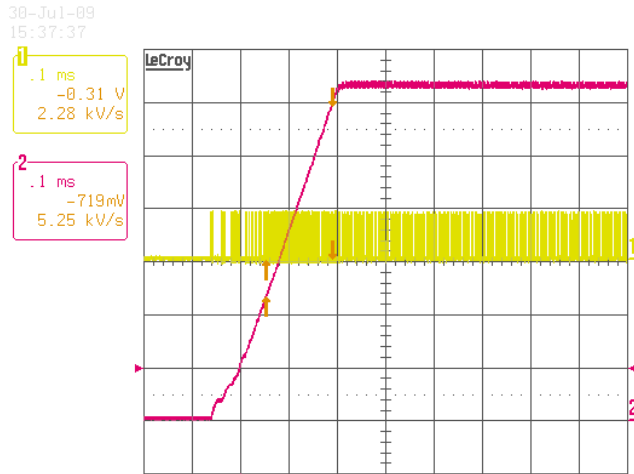
**FIGURE 51. 2-PHASE CPU MODE REFERENCE DESIGN LOOP GAIN T2(s) MEASUREMENT RESULT**



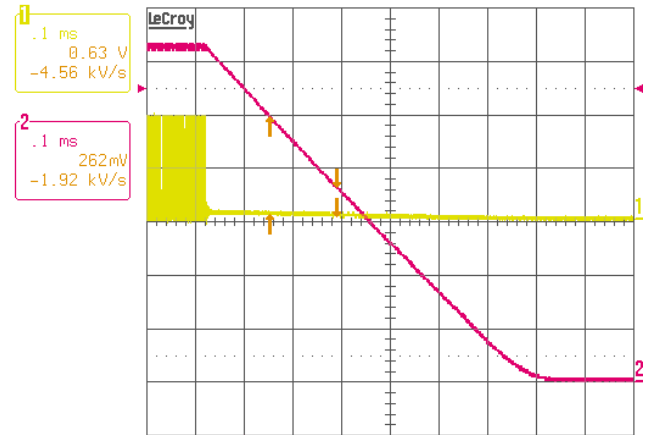
**FIGURE 52.  $I_{MON}$ ,  $V_{ID} = 1.075$**



**FIGURE 53. REFERENCE DESIGN FDIM RESULT**

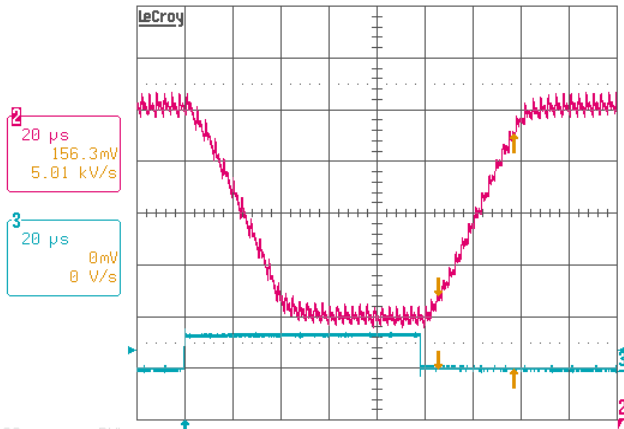


**FIGURE 54. 1-PHASE GPU MODE SOFT-START,  $DPRSLPVR=0$ ,  $V_{IN} = 8V$ ,  $I_O = 0A$ ,  $V_{ID} = 1.2375V$ , Ch1: PHASE1, Ch2:  $V_O$**

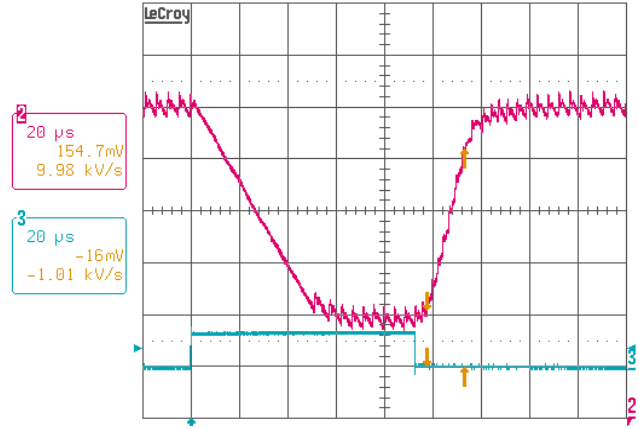


**FIGURE 55. 1-PHASE GPU MODE SHUT DOWN,  $V_{IN} = 8V$ ,  $I_O = 1A$ ,  $V_{ID} = 1.2375V$ , Ch1: PHASE1, Ch2:  $V_O$**

## Typical Performance (Continued)



**FIGURE 56. 1-PHASE GPU MODE VID TRANSITION, DPRSLPVR = 0,  $I_0 = 2A$ , VID = 1.2375V/1.0375V, Ch2:  $V_0$ , Ch3: VID4**



**FIGURE 57. 1-PHASE GPU MODE VID TRANSITION, DPRSLPVR = 1,  $I_0 = 2A$ , VID = 1.2375V/1.0375V, Ch2:  $V_0$ , Ch3: VID4**

© Copyright Intersil Americas LLC 2009-2011. All Rights Reserved.  
 All trademarks and registered trademarks are the property of their respective owners.

For additional products, see [www.intersil.com/en/products.html](http://www.intersil.com/en/products.html)

Intersil products are manufactured, assembled and tested utilizing ISO9001 quality systems as noted in the quality certifications found at [www.intersil.com/en/support/qualandreliability.html](http://www.intersil.com/en/support/qualandreliability.html)

*Intersil products are sold by description only. Intersil may modify the circuit design and/or specifications of products at any time without notice, provided that such modification does not, in Intersil's sole judgment, affect the form, fit or function of the product. Accordingly, the reader is cautioned to verify that datasheets are current before placing orders. Information furnished by Intersil is believed to be accurate and reliable. However, no responsibility is assumed by Intersil or its subsidiaries for its use; nor for any infringements of patents or other rights of third parties which may result from its use. No license is granted by implication or otherwise under any patent or patent rights of Intersil or its subsidiaries.*

For information regarding Intersil Corporation and its products, see [www.intersil.com](http://www.intersil.com)

## Revision History

The revision history provided is for informational purposes only and is believed to be accurate, but not warranted. Please go to web to make sure you have the latest Rev.

DATE	REVISION	CHANGE
5/6/11	FN6890.4	Updated to most current Intersil template. Page 8, Electrical Spec table: Added min and max limits for IMON Output Current, Condition ISUM – pin current = 5µA, Min: 22 Max: 37.5 Page 8, Note 6: Updated over temp note in Min Max column of spec tables from "Compliance to datasheet limits is assured by one or more methods: production test, characterization and/or design." To: "Parameters with MIN and/or MAX limits are 100% tested at +25° C, unless otherwise specified. Temperature limits established by characterization and are not production tested."
2/10/11	FN6890.3	Page 7, Electrical Spec table: removed min and max limits for IMON Output Current, Condition ISUM – pin current = 5µA Pg 2 - Updated Tape & Reel note in Ordering Information from "Add "-T" suffix for tape and reel." to new standard "Add "-T*" suffix for tape and reel." The "*" covers all possible tape and reel options. Removed -T FGs that are covered by "-T*" note (IRTZ-T, HRTZ-T, BHRTZ-T) Updated Intersil Trademark statement at bottom of page 1 per directive from Legal. Updated over temp note in Min Max column of spec tables from "Parameters with MIN and/or MAX limits are 100% tested at +25° C, unless otherwise specified. Temperature limits established by characterization and are not production tested." to new standard "Compliance to datasheet limits is assured by one or more methods: production test, characterization and/or design." Electrical Spec table: Removed Note 7 "Limits established by characterization and are not production tested." and references to it in the table. Updated L40.5x5 POD to rev .1. Changes from rev 0: Added Note 7 (JEDEC reference drawing: MO-220WHHE-1) Added Note 4 callout to Dimension b in bottom view
12/3/09	FN6890.2	Removed ISL62882A device from data sheet.
11/4/09	FN6890.2	Converted to new Intersil template. On page 19, Modes of Operation section last paragraph Changed from "Rbias = 147kohm enables the overshoot reduction function and Rbias = 47kohm disables it" to "Rbias = 147kohm disables the overshoot reduction function and Rbias = 47kohm enables it". Applied Intersil Standards as follows: Ordering information with notes and links, Added bold verbiage to Electrical spec conditions for over-temp and bolded min and max value columns. Pin Descriptions placed in Table.
8/24/09	FN6890.1	8/18/09 - See attached .doc file for changes. 7/10/09: Updated Figures 1, 2, 10, 11 and 27. Per Jia, "All the drawings have updated the way ISEN capacitors are connected. They used to be connected to from ISEN to GND, now they are connected from ISEN to Vo. It's an application patch that helps to avoid false IBAL fault during phase dropping due to an IC design error." Changed "GND" to "VSUM-" for pins 10 and 11 in table 5. Pin 10 now reads "A capacitor (C9) decouples it to VSUM-. Place it in general proximity of the controller." Pin 11 now reads "A capacitor (C10) decouples it to VSUM-. Place it in general proximity of the controller." 5/19/09: Changed under Recommended Operating Conditions- Battery Voltage VIN from "+5V to 21V" to "+5V to 25V"
04/01/09	FN6890.0	Initial Release to web

## Products

Intersil Corporation is a leader in the design and manufacture of high-performance analog semiconductors. The Company's products address some of the industry's fastest growing markets, such as, flat panel displays, cell phones, handheld products, and notebooks. Intersil's product families address power management and analog signal processing functions. Go to [www.intersil.com/products](http://www.intersil.com/products) for a complete list of Intersil product families.

\*For a complete listing of Applications, Related Documentation and Related Parts, please see the respective device information page on intersil.com: [ISL62882](http://www.intersil.com/products), [ISL62882B](http://www.intersil.com/products)

To report errors or suggestions for this datasheet, please go to [www.intersil.com/askourstaff](http://www.intersil.com/askourstaff)

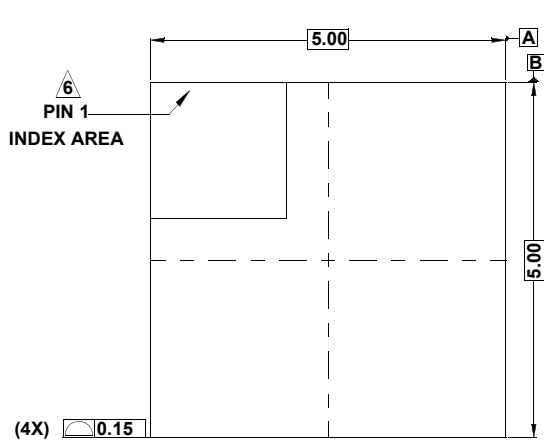
FITs are available from our website at <http://rel.intersil.com/reports/search.php>

# Package Outline Drawing

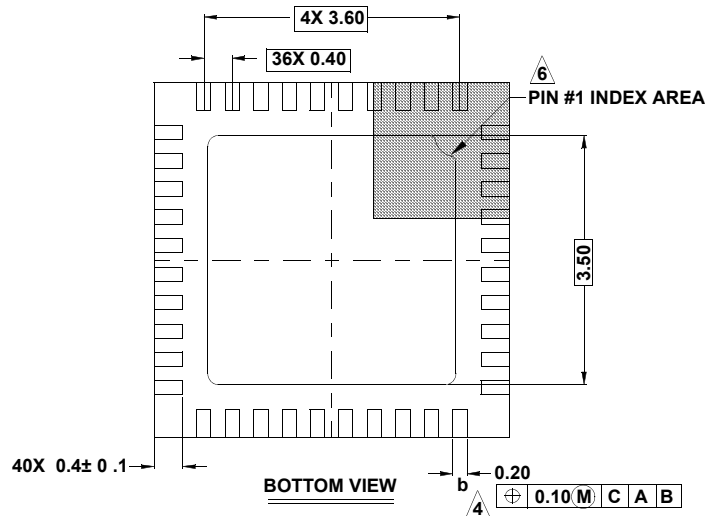
L40.5x5

40 LEAD THIN QUAD FLAT NO-LEAD PLASTIC PACKAGE

Rev 1, 9/ 10

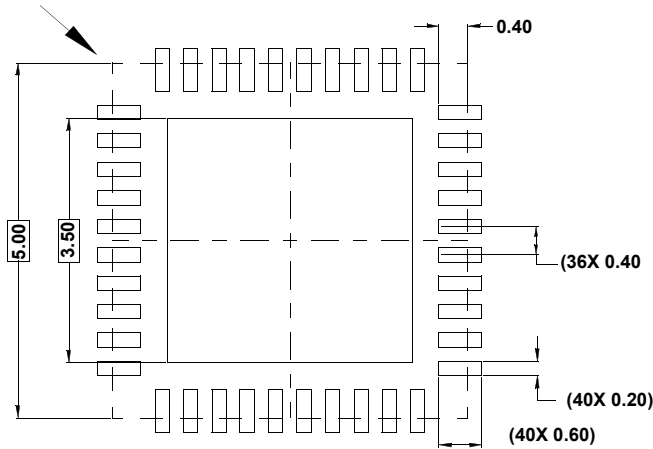


TOP VIEW

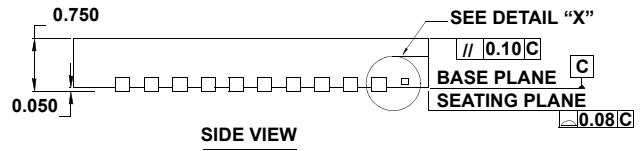


BOTTOM VIEW

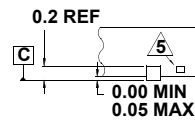
**PACKAGE OUTLINE**



TYPICAL RECOMMENDED LAND PATTERN



SIDE VIEW



DETAIL "X"

**NOTES:**

1. Dimensions are in millimeters.  
Dimensions in ( ) for Reference Only.
2. Dimensioning and tolerancing conform to AMSE Y14.5m-1994.
3. Unless otherwise specified, tolerance : Decimal ± 0.05
4. Dimension b applies to the metallized terminal and is measured between 0.15mm and 0.27mm from the terminal tip.
5. Tiebar shown (if present) is a non-functional feature.
6. The configuration of the pin #1 identifier is optional, but must be located within the zone indicated. The pin #1 identifier may be either a mold or mark feature.
7. JEDEC reference drawing: MO-220WHHE-1

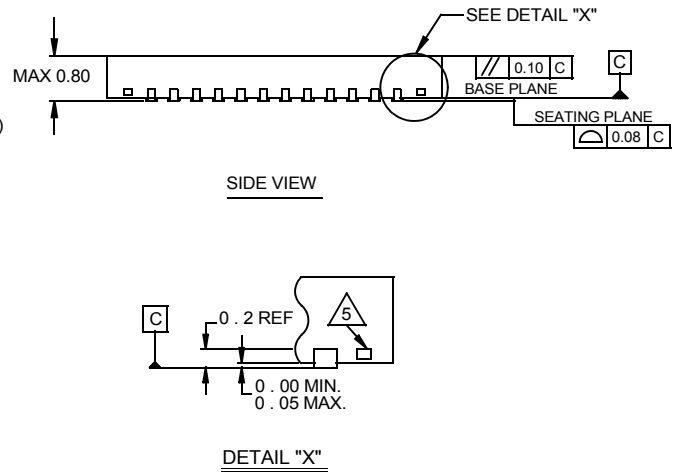
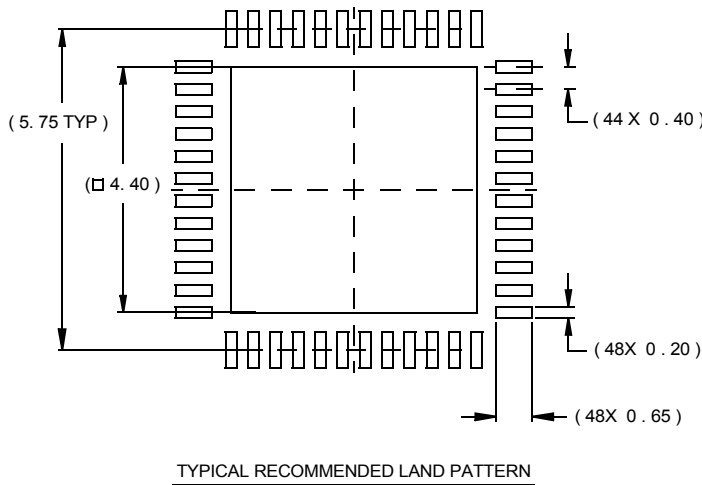
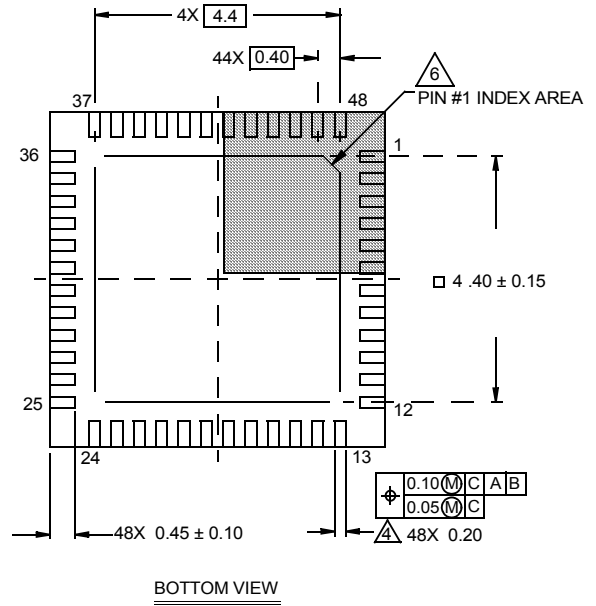
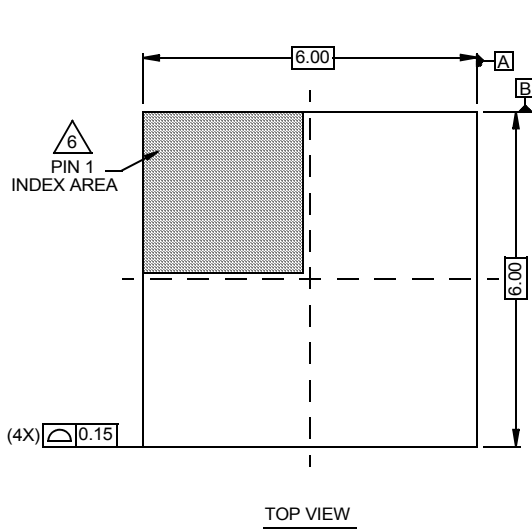


# Package Outline Drawing

## L48.6x6

48 LEAD THIN QUAD FLAT NO-LEAD PLASTIC PACKAGE

Rev 1, 4/07



NOTES:

1. Dimensions are in millimeters.  
Dimensions in ( ) for Reference Only.
2. Dimensioning and tolerancing conform to AMSE Y14.5m-1994.
3. Unless otherwise specified, tolerance : Decimal ± 0.05
4. Dimension b applies to the metallized terminal and is measured between 0.15mm and 0.30mm from the terminal tip.
5. Tiebar shown (if present) is a non-functional feature.
6. The configuration of the pin #1 identifier is optional, but must be located within the zone indicated. The pin #1 identifier may be either a mold or mark feature.