

DATA SHEET

Part No.	AN17831A
Package Code No.	HSIP012-P-0000E

Maintenance/Discontinued includes following lifecycle stage.
planned maintenance type
maintenance type
planned discontinued type
discontinued type
Please visit following URL about latest information.
<http://www.semicon.panasonic.co.jp/en/>

Contents

■ Applications	3
■ Package	3
■ Type	3
■ Application Circuit Example	4
■ Block Diagram	5
■ Pin Descriptions	5
■ Absolute Maximum Ratings	6
■ Operating Supply Voltage Range	6

Maintenance/Discontinued includes four Product lifecycle stage.
Discontinued
planned maintenance type
maintenance type
planned discontinued type
discontinued type
Please visit following URL about latest information.
<http://www.semicon.panasonic.co.jp/en/>

AN17831A

44 W (6 Ω) \times 2-channel BTL power amplifier built-in standby and muting features incorporating various protection circuits

■ Applications

- ICs for audio

■ Package

- SIL 12-pin plastic package (power type with fin)

■ Type

- Silicon monolithic bipolar IC

Maintenance/Discontinued

Maintenance/Discontinued includes four Product lifecycle stage.
planned maintenance type
maintenance type
planned discontinued type
discontinued type
Please visit following URL about latest information.
<http://www.semicon.panasonic.co.jp/en/>

■ Application Circuit Example

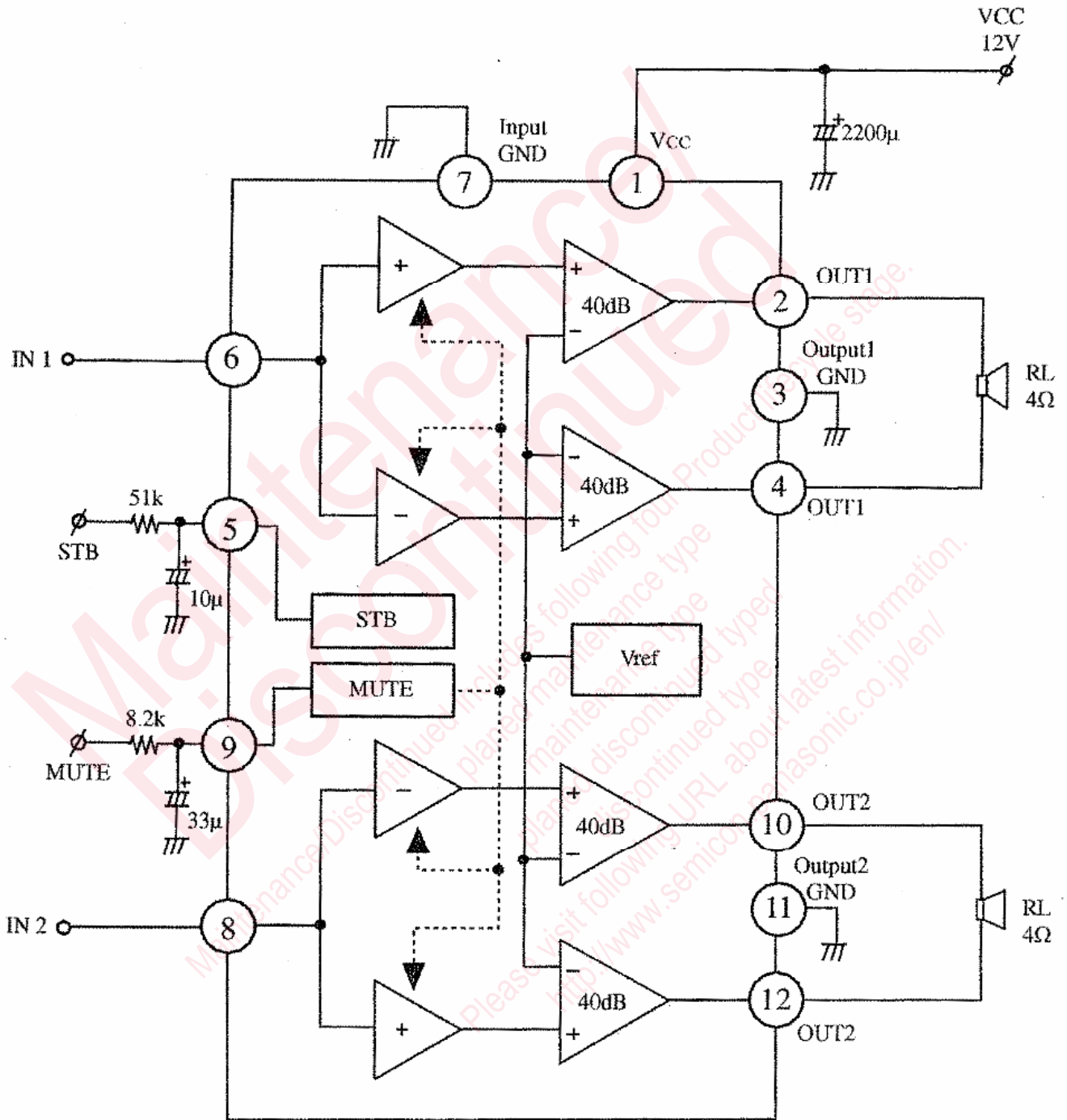

STB "off"	5 V
STB "on"	0 V
Mute "off"	0 V
Mute "on"	3 V

■ Block Diagram

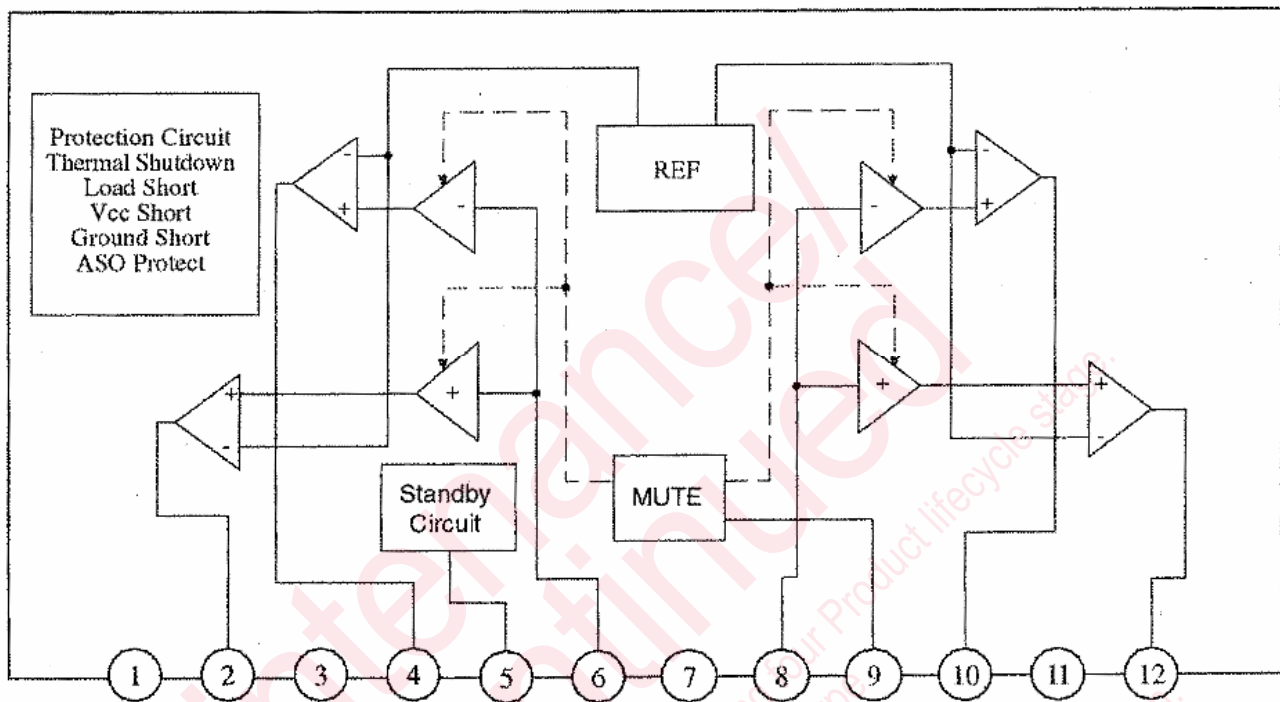

■ Pin Descriptions

Pin No.	Description	Pin No.	Description
1	V _{CC}	7	Pre GND
2	Channel 1 +ve phase output	8	Channel 2 input
3	Channel 1 output GND	9	Mute
4	Channel 1 -ve phase output	10	Channel 2 -ve phase output
5	Standby	11	Channel 2 output GND
6	Channel 1 input	12	Channel 2 +ve phase output

■ Absolute Maximum Ratings

A No.	Parameter	Symbol	Rating	Unit	Note
1	Supply voltage	V_{CC}	27	V	*1
2	Supply current	I_{CC}	8.0	A	
3	Power dissipation	P_D	37.5	W	*2
4	Storage temperature	T_{stg}	-55 to +150	°C	
5	Operating ambient temperature	T_{opr}	-25 to +75	°C	
6	Operating ambient atmospheric pressure	P_{opr}	$1.013 \times 10^5 \pm 0.61 \times 10^5$	Pa	
7	Operating constant gravity	G_{opr}	9 810	m/S ²	
8	Operating shock	S_{opr}	4 900	m/S ²	

Note) *1: Without input signal, V_{CC} is up to 27 V.

*2: $T_a = 75^\circ\text{C}$. For the independent IC without a heat sink.

■ Operating Supply Voltage Range

Parameter	Symbol	Range	Unit	Note
Supply voltage range	V_{CC}	8.0 to 26.5	V	*1

Note) *1: V_{CC} up to 26.5 V can be used as long as the ratings of the IC are not exceeded.

Request for your special attention and precautions in using the technical information and semiconductors described in this book

- (1) If any of the products or technical information described in this book is to be exported or provided to non-residents, the laws and regulations of the exporting country, especially, those with regard to security export control, must be observed.
- (2) The technical information described in this book is intended only to show the main characteristics and application circuit examples of the products, and no license is granted under any intellectual property right or other right owned by our company or any other company. Therefore, no responsibility is assumed by our company as to the infringement upon any such right owned by any other company which may arise as a result of the use of technical information described in this book.
- (3) The products described in this book are intended to be used for standard applications or general electronic equipment (such as office equipment, communications equipment, measuring instruments and household appliances).
Consult our sales staff in advance for information on the following applications:
 - Special applications (such as for airplanes, aerospace, automobiles, traffic control equipment, combustion equipment, life support systems and safety devices) in which exceptional quality and reliability are required, or if the failure or malfunction of the products may directly jeopardize life or harm the human body.
 - Any applications other than the standard applications intended.
- (4) The products and product specifications described in this book are subject to change without notice for modification and/or improvement. At the final stage of your design, purchasing, or use of the products, therefore, ask for the most up-to-date Product Standards in advance to make sure that the latest specifications satisfy your requirements.
- (5) When designing your equipment, comply with the range of absolute maximum rating and the guaranteed operating conditions (operating power supply voltage and operating environment etc.). Especially, please be careful not to exceed the range of absolute maximum rating on the transient state, such as power-on, power-off and mode-switching. Otherwise, we will not be liable for any defect which may arise later in your equipment.
Even when the products are used within the guaranteed values, take into the consideration of incidence of break down and failure mode, possible to occur to semiconductor products. Measures on the systems such as redundant design, arresting the spread of fire or preventing glitch are recommended in order to prevent physical injury, fire, social damages, for example, by using the products.
- (6) Comply with the instructions for use in order to prevent breakdown and characteristics change due to external factors (ESD, EOS, thermal stress and mechanical stress) at the time of handling, mounting or at customer's process. When using products for which damp-proof packing is required, satisfy the conditions, such as shelf life and the elapsed time since first opening the packages.
- (7) This book may be not reprinted or reproduced whether wholly or partially, without the prior written permission of Matsushita Electric Industrial Co., Ltd.