

GLF1511**4 A Ultra Low Current Consumption N-channel Load Switch
with Lower Input Voltage Range****DESCRIPTION**

The GLF1511 load switch is a fully integrated 4 A NMOS load switch with I_QSmart™ advanced technology. The device is ideal for the mobile computing and data storage markets as a high performance solution for load switch applications.

The GLF1511 provides a constant low on-resistance of 13 mΩ at the full input voltage range. The fixed rise time helps prevent undesirable inrush current when turned on and the internal EN pin pulldown resistor ensures the device remains in the shutdown mode when disabled. In shutdown mode the GLF1511 consumes ultra-low current at the wide input supply voltage.

The GLF1511 features a reverse current blocking protection. When the GLF1511 is disabled, it prevents reverse current flowing from the output to the input source.

The GLF1511 is available in a wafer level chip scale package (WLCSP) measuring 0.97 mm x 1.47 mm x 0.55 mm with a 0.5 mm pitch. This allows the user to save board space.

The GLF1511 evaluation board (EVB) EV007 supports the user to evaluate GLF1511 load switch. The test point connections allow the user to test the key parameters like R_{ON}, rise time and output discharge resistor etc easily.

FEATURES

- Supply Voltage Range: 0.7 V to 5.5 V
- Low R_{ON}: 13 mΩ Typ
- I_{OUT} Max: 4 A
- Ultra-Low I_Q:
 - 2 μA Typ at 0.7 V_{IN}
 - 14 μA Typ at 3.3 V_{IN}
 - 30 μA Typ at 5.5 V_{IN}
- Ultra-Low I_{SD}:
 - 0.015 μA Typ at 0.7 V_{IN}
 - 0.030 μA Typ at 5.5 V_{IN}
- Controlled V_{OUT} Turn-on Time
- Internal EN Pull-Down Resistor
- Integrated Output Discharge Switch
- Reverse Current Blocking Protection When Disabled
- Operating Temperature Range: - 40 °C to 105 °C
- HBM: 8 kV, CDM: 2 kV
- 0.97 mm x 1.47 mm x 0.55 mm, 6 Bumps Wafer Level Chip Scale Package

PRODUCT TABLE

Eval Board Ordering Info	Part Number	R_{ON} (Typ.)	Output Discharge	t_r @3.3V _{IN}	EN Activity
EV007-GLF1511	GLF1511	13 mΩ	250 Ω	360 μs	High

EVALUATION BOARD & DEVICE PACKAGE

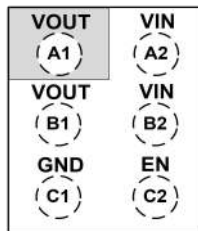

TOP VIEW

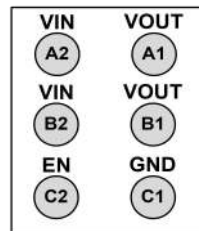

BOTTOM VIEW

Pin #	Name	Description
A1, B1	V _{OUT}	Switch Output
A2, B2	V _{IN}	Switch Input. Supply Voltage for IC
C1	GND	Ground
C2	EN	Enable to control the switch

QUICK START GUIDE

The evaluation board EV007 is easy to set up to evaluate the performance of GLF1511.

1. Preset the input power supply to the desired voltage. The input voltage range of the GLF1511 is 0.7 V to 5.5 V.
2. The load resistor, RL1=150 Ω, has been populated on the top of the PC board. Short the J2 to use the RL1=150 Ω or RL2 which is not populated on the bottom. To increase the output current, connect an electronic load to VOUT

and GND. The output current for the GLF1511 is rated for 4 A maximum output continuous current. Please ensure this absolute maximum is not exceeded.

3. Connect the positive and negative terminals of the input power supply to VIN and GND terminals respectively. VIN_Sense and VOUT_Sense can be used for measurement points.
4. Turn on the input power supply.

5. Configure the J1, EN jumper as required. Note - GLF1511 as an internal EN pull-down resistor to ensure the part is in a defined state.
6. To test I_Q and I_{SD} , a high precision multi-meter is needed to be inserted in series with the input power supply. Please note that there is the pull-down resistor at EN pin inside the device, and the current flowing through this resistor should be extracted from the test result.
7. To measure on-resistance R_{ON} , the voltage drop across the switch should be measured at the pins of V_{in_Sense} and V_{out_Sense} . This value is then divided by the current into the load, yielding the R_{ON} resistance.
8. To test the slew rate, enable the device and apply the input voltage to input pin and ground pin. Capture the waveforms of V_{IN} and V_{OUT} with a scope to measure the slew rate and rise time of the switch.

TEST SETUP

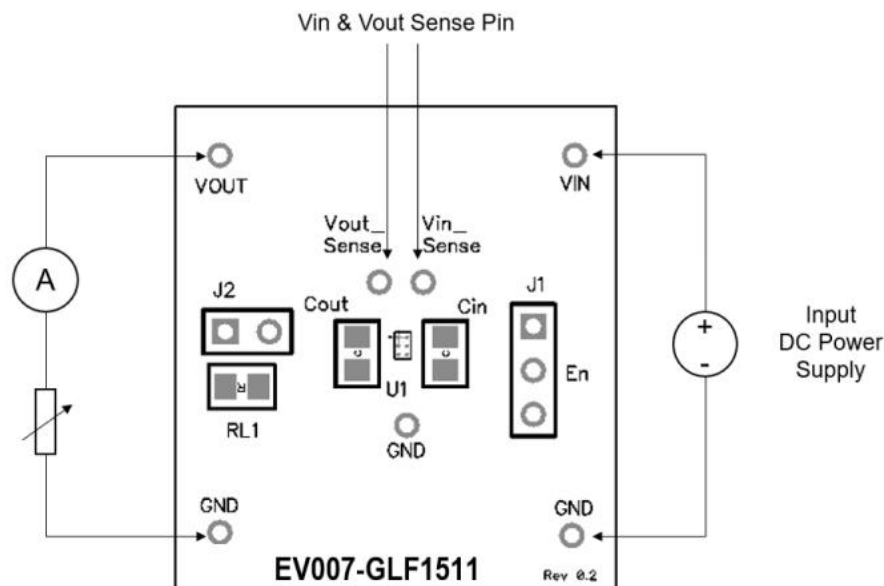

J1-EN

This is the enable selection for the device. A shorting jumper is installed on J1 in either the high or low position to enable or disable the device. Don't leave EN floating.

J2-Output Load Connection

This is the connection of load resistors to the output by a shorting jumper.

SCHEMATIC

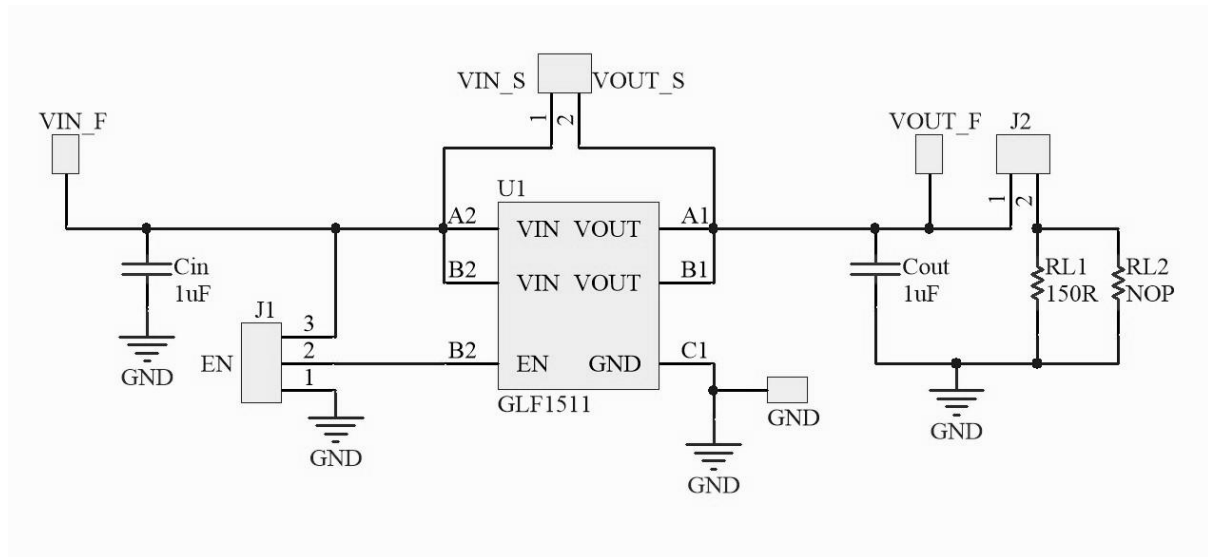

BILL OF MATERIALS

Qty	Reference	Value	Part Description	Manufacturer/ Part Number
1	U1	GLF1511	GLF1511	GLF Integrated Power
2	Cin, Cout	1.0 µF	Cap., X7R, 50 V, 10% 0805	YAGEO CC0805KKX7R9BB105
1	RL1	150 Ω	Load Resistor	YAGEO RC0805FR-07150RL
1	RL2	-	Load Resistor	Not populated on the board
2	J1, J2	Jumper	Jumper, 2.54 mm	

PRINTED CIRCUIT BOARD LAYOUT

Top Layer

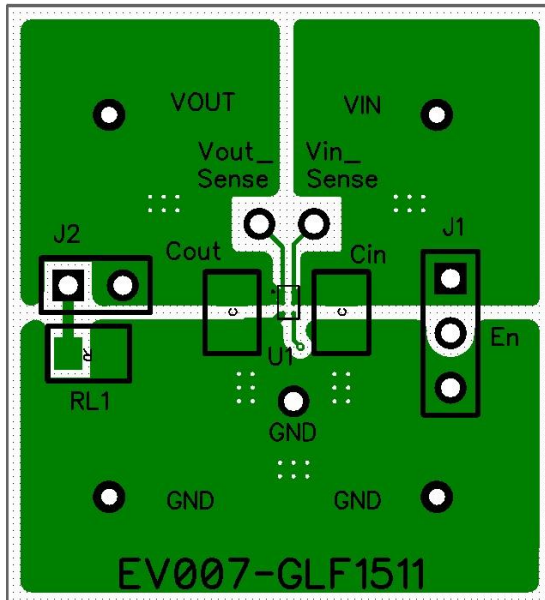

Bottom Layer

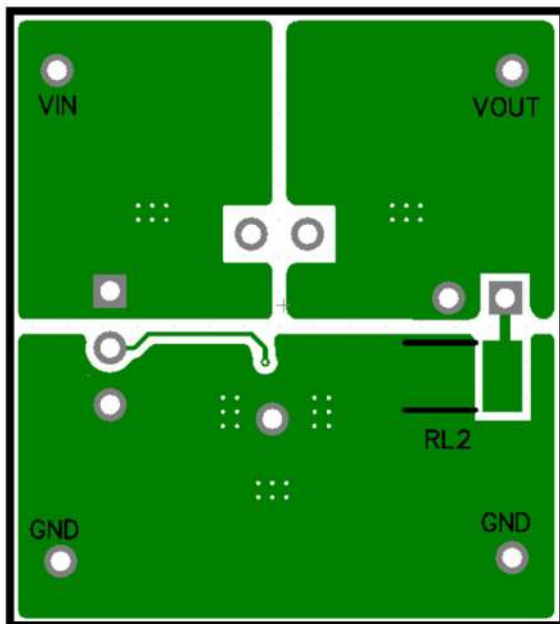

NOTICE: The evaluation board provided by GLF Integrated Power is intended for use for ENGINEERING DEVELOPMENT, OR EVALUATION PURPOSES ONLY and is not for any commercial use. The user assumes all responsibility and liability for proper and safe handling of the goods.