

REVISIONS				
P	LTR	DESCRIPTION	DATE	APVD
H2		REVISED PER ECN-22-150900	27APR2022	RK CSD

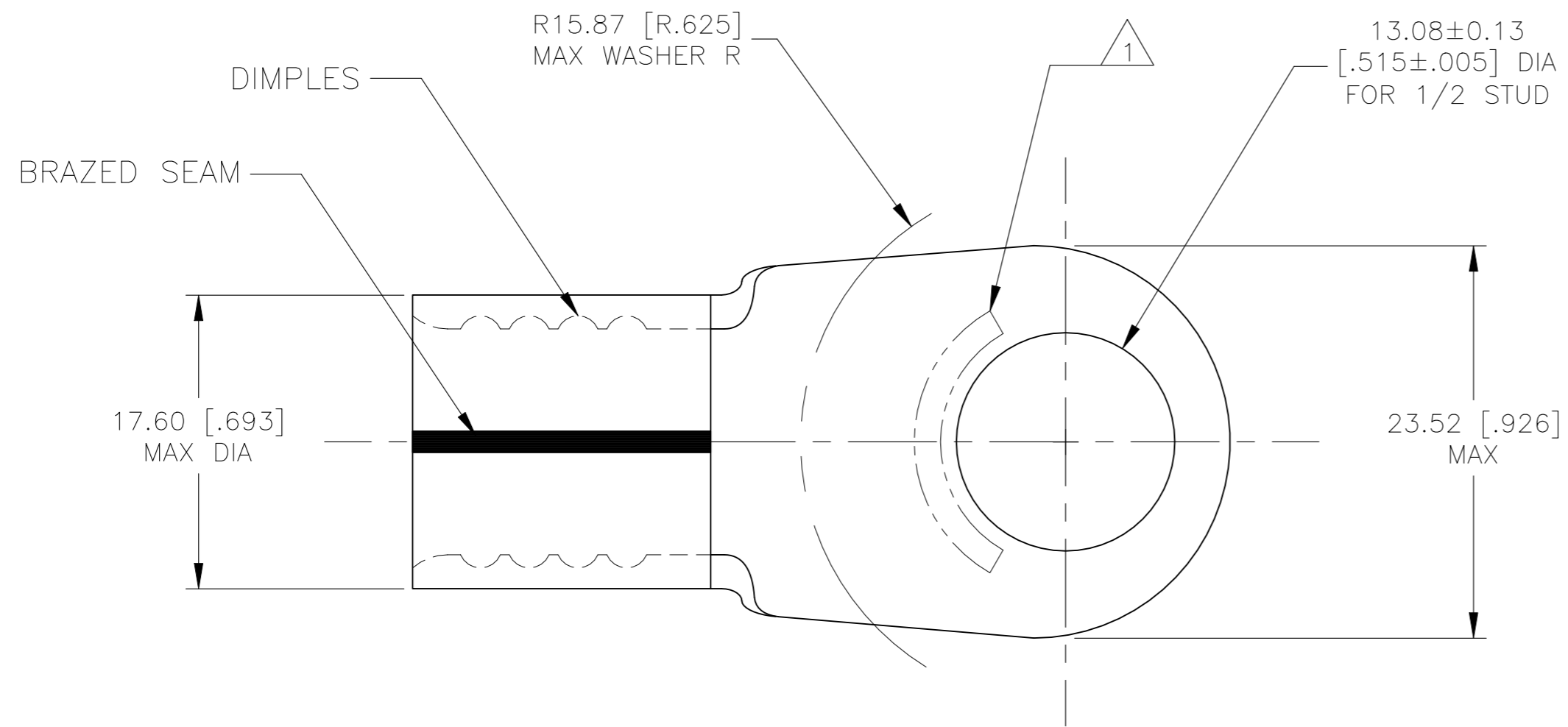

<b>AMP</b> WIRE RANGE	Listed FILE E13288	LR7189 Certified
2/0 AWG SOLID OR STRANDED	2/0 AWG STRANDED	2/0 AWG SOLID OR STRANDED

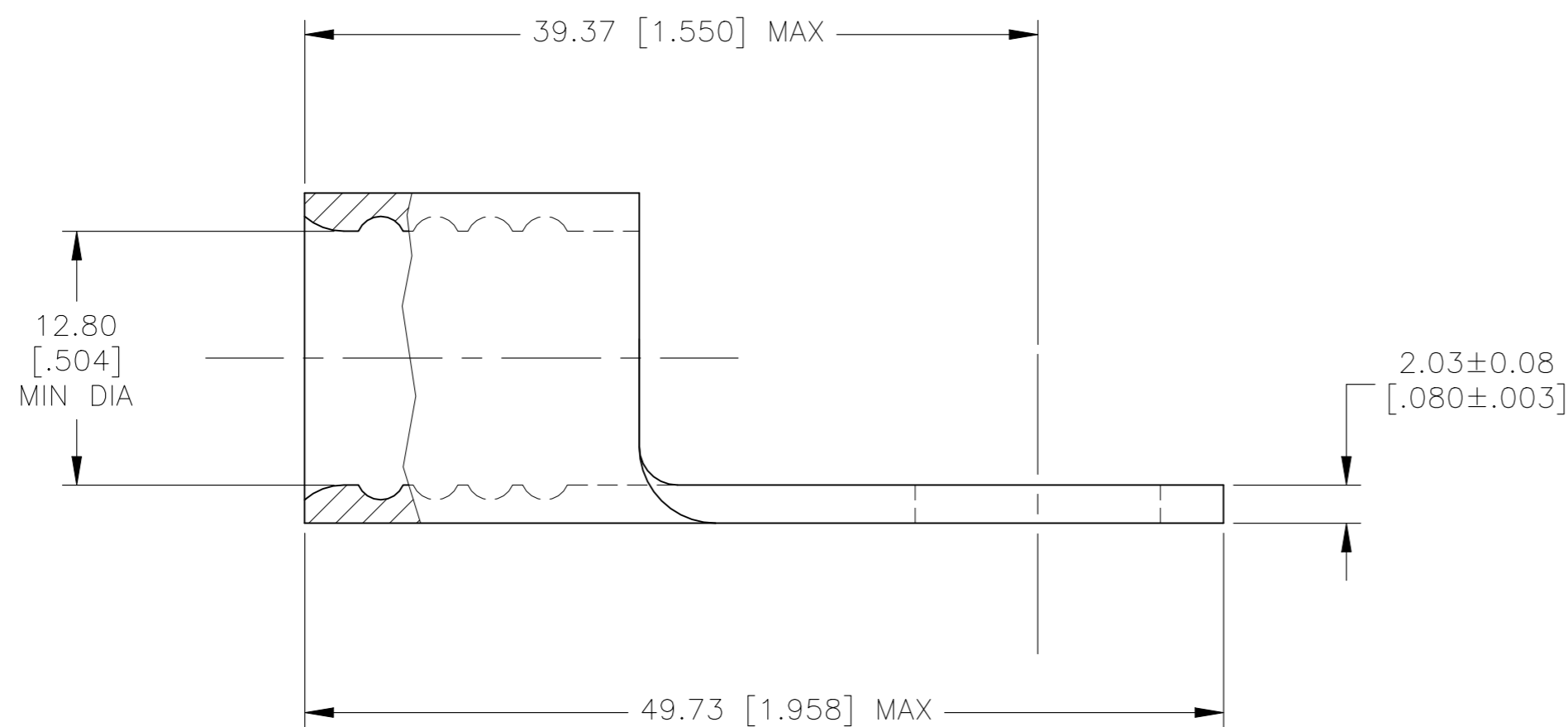

- 1 STAMP AMP 2/0W\* APPROX AS SHOWN.
- 2 TIN PLATE 0.00254 [.000100] MIN THK PER ASTM B-545.
- 3 BRIGHT TIN LEAD PLATE 0.00254 [.000100] MIN EXT THK PER B-545.
- 4 COPPER PER ASTM B-152, ANNEALED.
- 5 NOTE DELETED
- 6 NICKEL PLATE 0.00762 [.00030] MIN EXT. THK. PER SAE AMS QQ-N-290.
- 7 NOT UL OR CSA APPROVED FOR STRANDED WIRE ONLY.

170°C [338°F]	50	LOOSE PIECE	3	2-321873-2
343°C [650°F]	50	LOOSE PIECE	6	321873-2
170°C [338°F]	50	LOOSE PIECE	2	321873
MAX RECOMMENDED OPERATING TEMP.	QTY	PACKAGE TYPE	FINISH	PART NO.

MAX RECOMMENDED OPERATING TEMPERATURE: SEE TABLE	THIS DRAWING IS A CONTROLLED DOCUMENT.		DWN DK_SCHRUM 1/14/94	TE Connectivity
	VOLTAGE RATING: N/A	DIMENSIONS: MM [INCHES]	CHK AJ KAUFMAN 1/19/94	
CIRCULAR MIL AREA: 60.6-76.3mm <sup>2</sup> [119,500-150,500] SOLID OR STRANDED	TOLERANCES UNLESS OTHERWISE SPECIFIED: 0 PLC ± - 1 PLC ± - 2 PLC ± 0.20 [.008] 3 PLC ± - 4 PLC ± - ANGLES ± -	APVD JL MECKLEY 1/19/94	PRODUCT SPEC APPLICATION SPEC	SIZE A2
MATERIAL 4	FINISH SEE TABLE	WEIGHT -	SCALE 2:1	CAGE CODE 00779
		CUSTOMER DRAWING	DRAWING NO C=321873	RESTRICTED TO -
			SCALE 2:1	SHEET 1 of 1
				REV H2