

Solid State Pressure Sensors

D8M

Solid State Pressure Sensors with Analog, Pulse or Frequency Outputs

- Compact housing measures 30L x 30W x 12.4H mm.
- Accept 4 mm OD tubing (D8M-A1, -R1); 3 mm OD tubing for (D8M-D1, -D2), 6 mm OD tubing for D8M-D82.
- Chemical-resistant plastic (PBT) body.
- Metal shield mounted version (D8M-D82) available.
- IP40 enclosure rating for embedded applications.
- Pre-wired and PCB mounting models available.



Ordering Information

Operating pressure range	Output signal	Output frequency	Power supply voltage	Withstand pressure	Model
0 to 4.9 kPa (0 to 0.71 psi)	Analog, 15 to 1247 mV	--	2.2 ±0.1 VDC	58.8 kPa (8.53 psi) for 3 minutes	D8M-A1
0 to 5.88 kPa (0 to 0.85 psi)	Pulse count, 1 pulse/9.81 Pa (1/0.0014 psi)	--	2.2 to 3.4 VDC with regulator	58.8 kPa (8.53 psi) for 3 minutes	D8M-D1
0 to 5.88 kPa (0 to 0.85 psi)	Pulse count, 1 pulse/9.81 Pa (1/0.0014 psi)	--	2.2 to 3.4 VDC with regulator	58.8 kPa (8.53 psi) for 3 minutes	D8M-D2
0 to 4.9 kPa (0 to 0.71 psi)	Pulse count, 1 pulse/9.81 Pa (1/0.0014 psi)	--	2.2 to 3.4 VDC with regulator	19.6 kPa (2.84 psi) for 5 minutes	D8M-D82
0 to 196.13 Pa (0 to 0.028 psi)	Frequency, 1 kHz/9.81 Pa (1 kHz/0.0014 psi)	80 to 300 kHz	4.2 to 5.5 VDC with regulator	3 kPa (0.435 psi) for 10 seconds	D8M-R1

Specifications

■ Electrical Ratings

Item	D8M-A1	D8M-D1	D8M-D2	D8M-D82	D8M-R1
Power supply voltage	2.2 ±0.1 VDC	2.2 to 3.4 VDC with regulator	2.2 to 3.4 VDC with regulator	2.2 to 3.4 VDC with regulator	4.2 to 5.5 VDC with regulator
Current consumption	2.5 mA max.	25 mA max.	25 µA	100 mA ±5% at 3 VDC	10 mA max.
Load resistance	1 MΩ min.	--	--	--	--
Output resistance	500 Ω max.	--	--	--	--
Leakage current	1 mA or less	1 mA or less	1 mA or less	1 mA or less	1 mA or less
Output voltage	15 to 1247 mV	--	--	--	--
Output pulses	--	--	--	--	80 to 300 kHz
Output resolution	(Note 1)	1 pulse/9.81 Pa	1 pulse/9.81 Pa	1 pulse/9.81 Pa	1 kHz/9.81 Pa
Output voltage rate of change with resistance load change	1 MΩ or more into 30 kΩ is made within 2.5%	--	--	--	--
Output voltage by input pressure	0.98 kPa = 261 mV 1.96 kPa = 508 mV 3.73 kPa = 951 mV 4.9 kPa = 1247 mV (Note 1)	--	--	--	--
Operating characteristics	±62 mV initial	--	--	--	--
	±37 mV during test and after	0 kPa = 30 pulses 0.59 kPa = 60 ±32 pulses 1.96 kPa = 200 ±24 pulses 3.73 kPa = 380 ±24 pulses 5.39 kPa = 530 ±82 pulses (Note 2)	0 kPa = 30 pulses 0.59 kPa = 60 ±32 pulses 1.96 kPa = 200 ±24 pulses 3.73 kPa = 380 ±24 pulses 5.39 kPa = 550 ±82 pulses (Note 2)	0 kPa = 30 pulses 0.15 kPa = 45 ±30 pulses 2 kPa = 204 ±15 pulses 4 kPa = 438 ±46 pulses	0 Pa = 180 ±100 kHz; Incremental change from 0 value: 49.03 Pa = 5 ±0.9 kHz 73.55 Pa = 7.5 ±1.0 kHz 147.10 Pa = 15 ±0.8 kHz 196.13 Pa = 20 ±1.4 kHz (Note 2)
	±62 mV temperature influence	--	--	--	--

Note: 1. Output voltage (mV) = Supply voltage V (2.2) x (2.464 x Pressure (kPa)/9.8 x 1000 + 15)

2. Values measured during and after testing.

■ Operating Characteristics

Item	D8M-A1	D8M-D1	D8M-D2	D8M-D82	D8M-R1
Pressure type	Gauge				
Pressure range	0 to 4.9 kPa (0 to 0.71 psi)	0 to 5.88 kPa (0 to 0.85 psi)	0 to 5.88 kPa (0 to 0.85 psi)	0 to 4.9 kPa (0 to 0.71 psi)	0 to 196.13 Pa (0 to 0.028 psi)
Withstand pressure	5.88 kPa for 3 minutes	58.8 kPa for 3 minutes	58.8 kPa for 3 minutes	19.6 kPa for 5 minutes	3 kPa for 10 seconds
Repeatability/hysteresis	±0.5% FS	±0.5% FS	NA	±0.5% FS	±0.5% FS
Non-linearity characteristics	--	--	--	±2% FS max.	±2% FS max.
Response time	3.0 ms	2.5 ms (pressure) 18 ms max. (switch) 100 ms (discharge)	3 ms (pressure) 32 ms max. (switch) 250 ms (discharge)	1.5 ms (pressure) 30 ms max. (switch) 45 ms (discharge)	3 seconds max.
Operating temperature (Note)	-30° to 70°C	-30° to 70°C	-30° to 70°C	-10° to 60°C	-20° to 70°C
Storage temperature (Note)	-40° to 80°C	-40° to 80°C	-40° to 80°C	-20° to 70°C	-30° to 80°C
Operating humidity	25 to 95%	25 to 95%	25 to 95%	25 to 95%	25 to 95%

Note: With no icing or condensation

■ Environmental Characteristics

Item	D8M-A1	D8M-D1	D8M-D2	D8M-D82	D8M-R1
Insulation resistance	100 mΩ min., 250 VDC between lead terminals and the base				
Dielectric strength	250 VAC, 50/60 Hz for 1 minute between lead terminals and the base				500 VAC, 50/60 Hz for 1 minute between terminals and the base
Degree of protection	NA	IP40	IP40	IP40	IP40
Pressure port	4 mm OD	3 mm OD	3 mm OD	6 mm OD	4 mm OD
Connection method	Solder on PC boards	Wiring connector on top	Wiring connector on top	Three AWG26 wires, 115 mm long	Wiring connector on bottom
Weight	NA	NA	NA	NA	NA
Material	PBT (polybutylene terephthalate)				

Operation

■ Response Timing Charts

D8M-D1, D2, D82

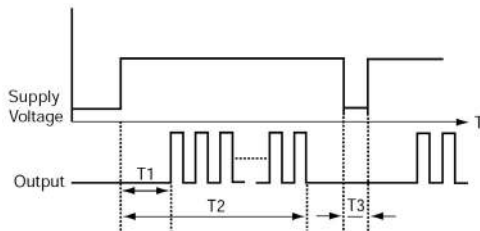

Model	T1	T2	T3
D8M-D1	2.5 ms min.	18 ms max.	100 ms min.
D8M-D2	3.0 ms min.	32 ms max.	250 ms min.
D8M-D82	1.5 ms min.	30 ms max.	45 ms max.

Legend: T1, Pressure measurement time
 T2, Response time
 T3, Electrical discharge time

D8M-R1

Response time to 90% of 0.2kPa
 Max. 3 seconds (excluding time for pressure change)

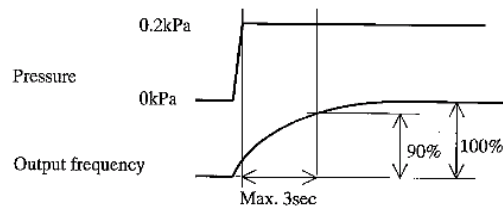

Application Examples

Compact D8M solid state pressure sensors provide reliable detection for gas and air inflow for burner controls in water heaters, furnaces and other gas-fired devices. They can also be used in gas usage meters.



■ Interface Circuit Diagram

D8M-R1

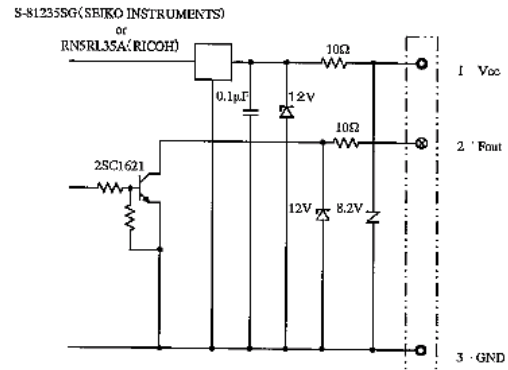

Dimensions

Unit: mm (inch)

■ D8M-A1

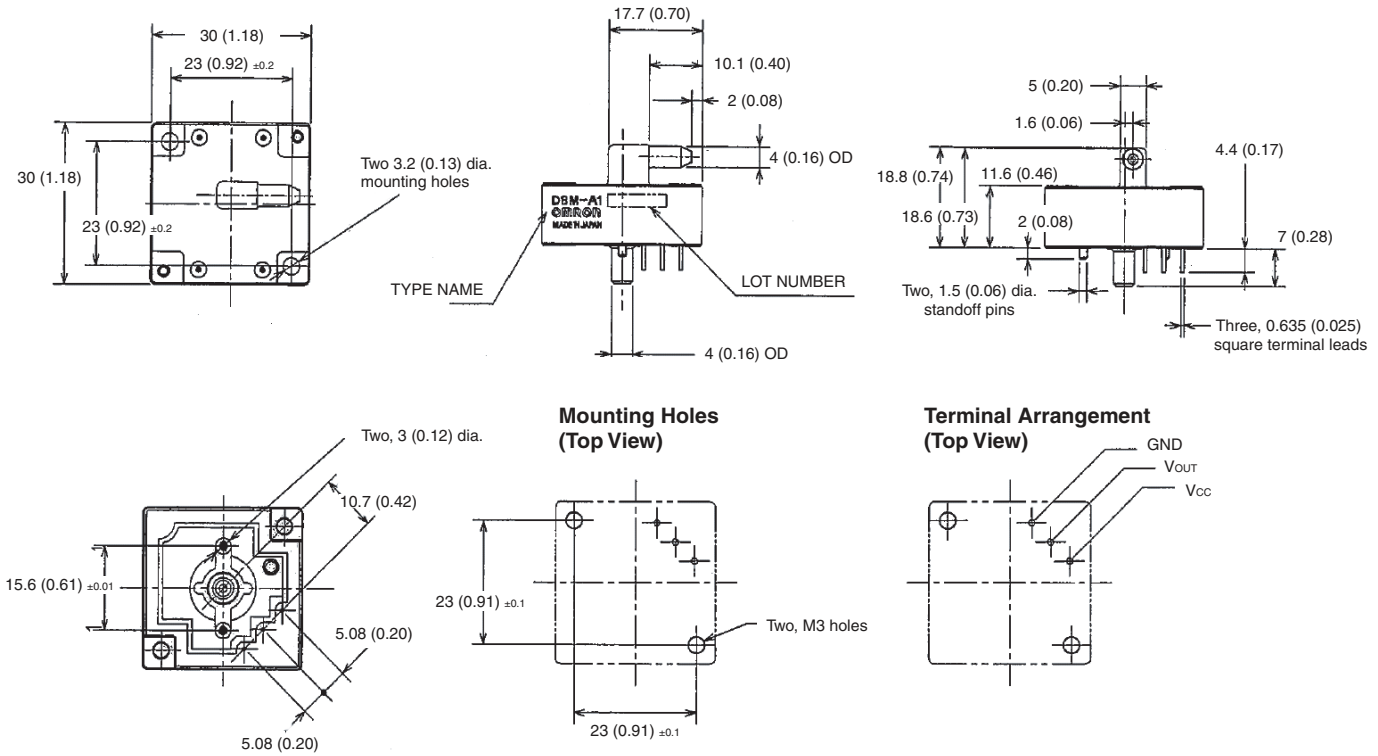

■ D8M-D1

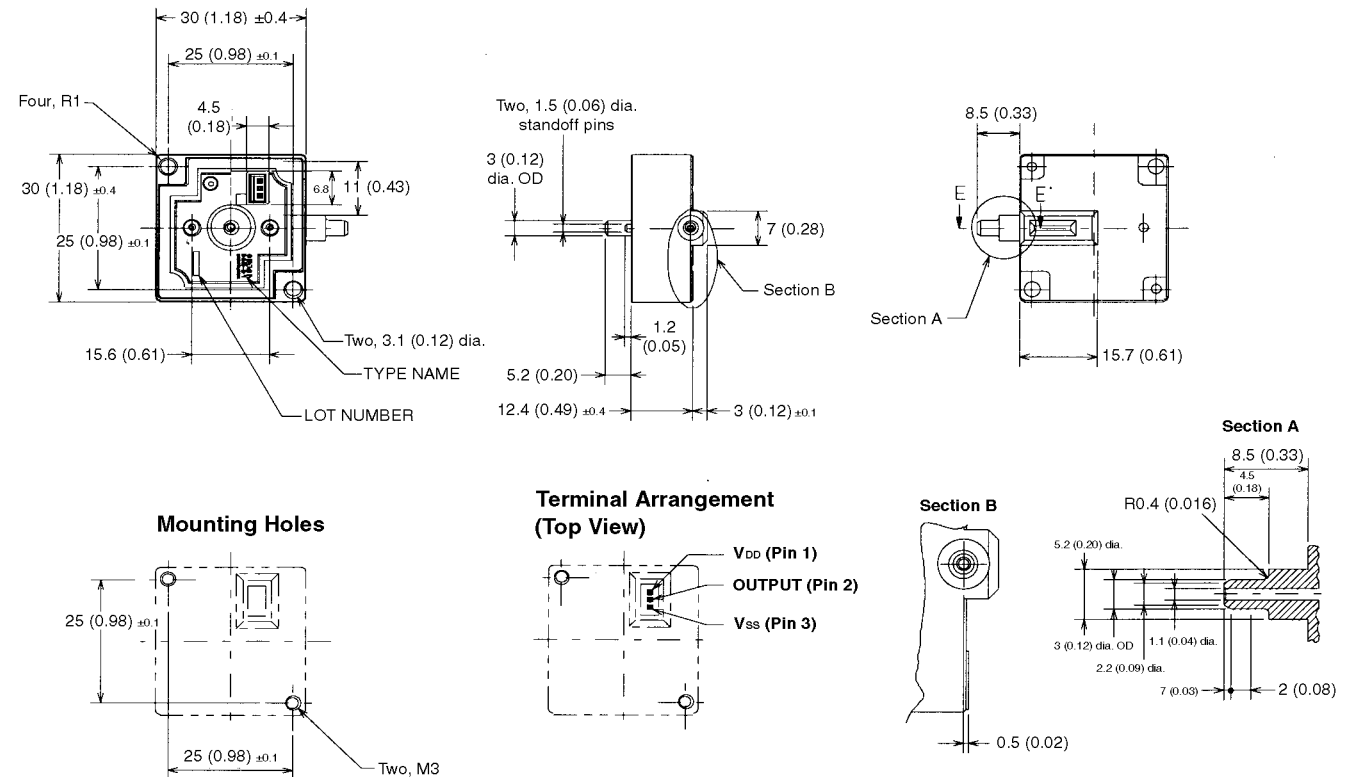

■ D8M-D2

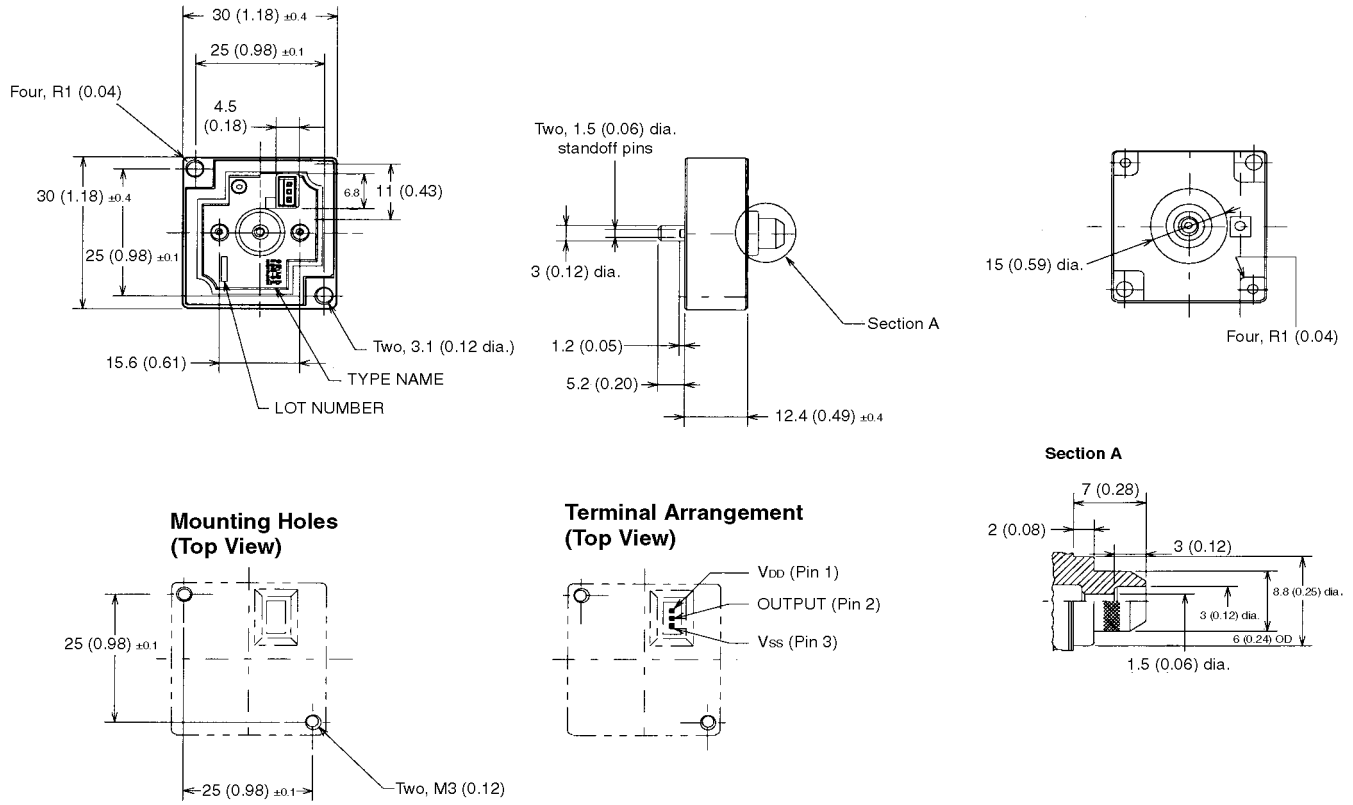

■ D8M-D82

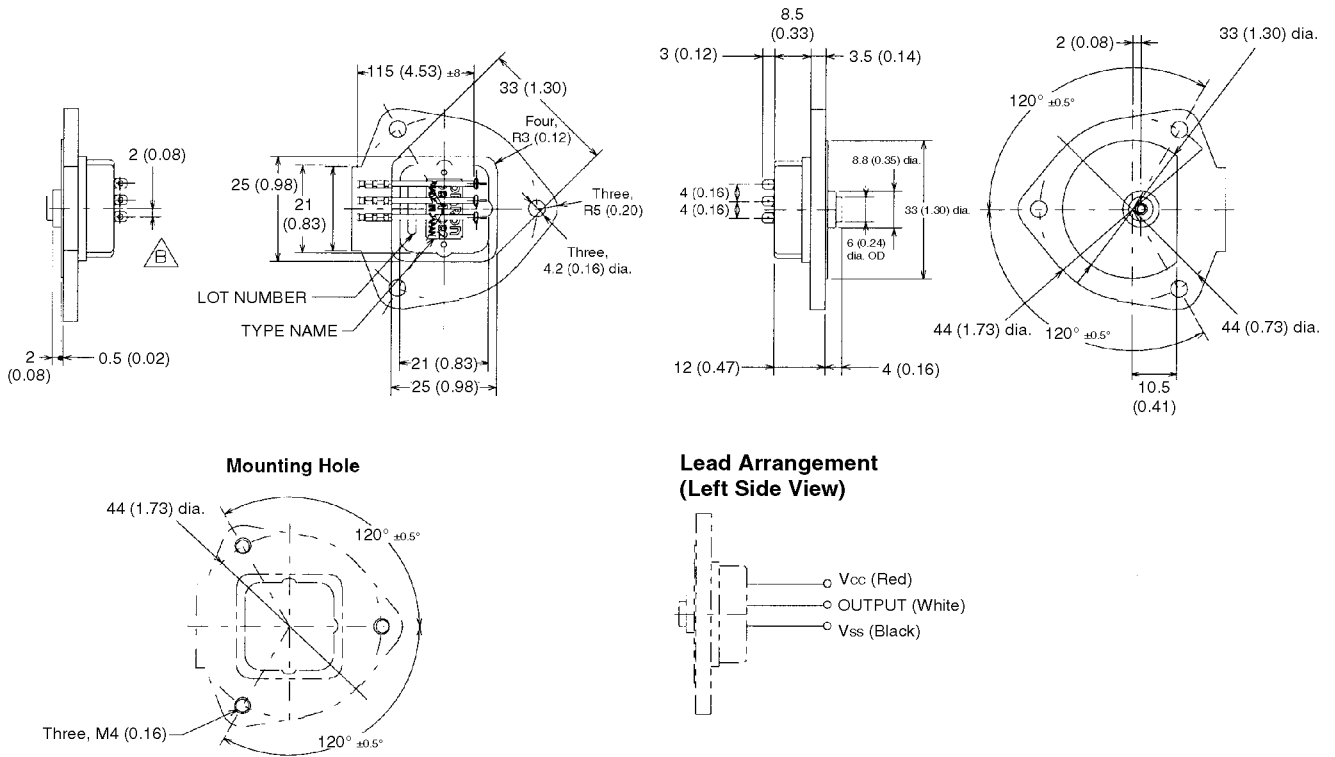

■ D8M-R1

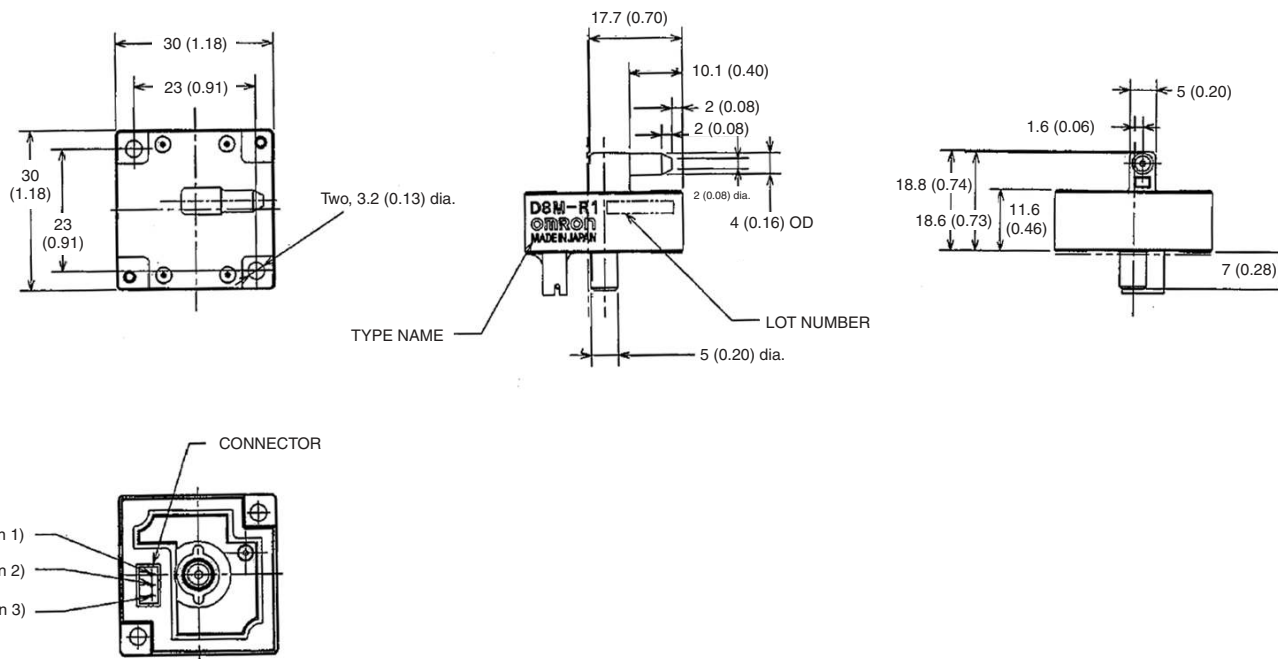

Precautions

Be sure to abide by the following precautions for the safe operation of the Sensor.

■ Soldering

Solder D8M-A1 on PC boards within 5 seconds using a soldering iron whose tip temperature is adjusted to 345° to 355°C.

■ Mounting

For proper operation, mount the sensor within ±10 degrees of level.

ALL DIMENSIONS SHOWN ARE IN MILLIMETERS. To convert millimeters into inches, divide by 25.4



OMRON ELECTRONICS LLC
 One Commerce Drive
 Schaumburg, IL 60173
847-882-2288

OMRON CANADA, INC.
 885 Milner Avenue
 Toronto, Ontario M1B 5V8
416-286-6465

OMRON ON-LINE
 Global - <http://www.omron.com>
 USA - <http://www.omron.com/oei>
 Canada - <http://www.omron.ca>