

LOC	DIST	REVISIONS					
		P	LTN	DESCRIPTION	DATE	DMN	APVD
AD	00	F		REVISED PER ECR-14-016951	11FEB2015	J.T	W.H

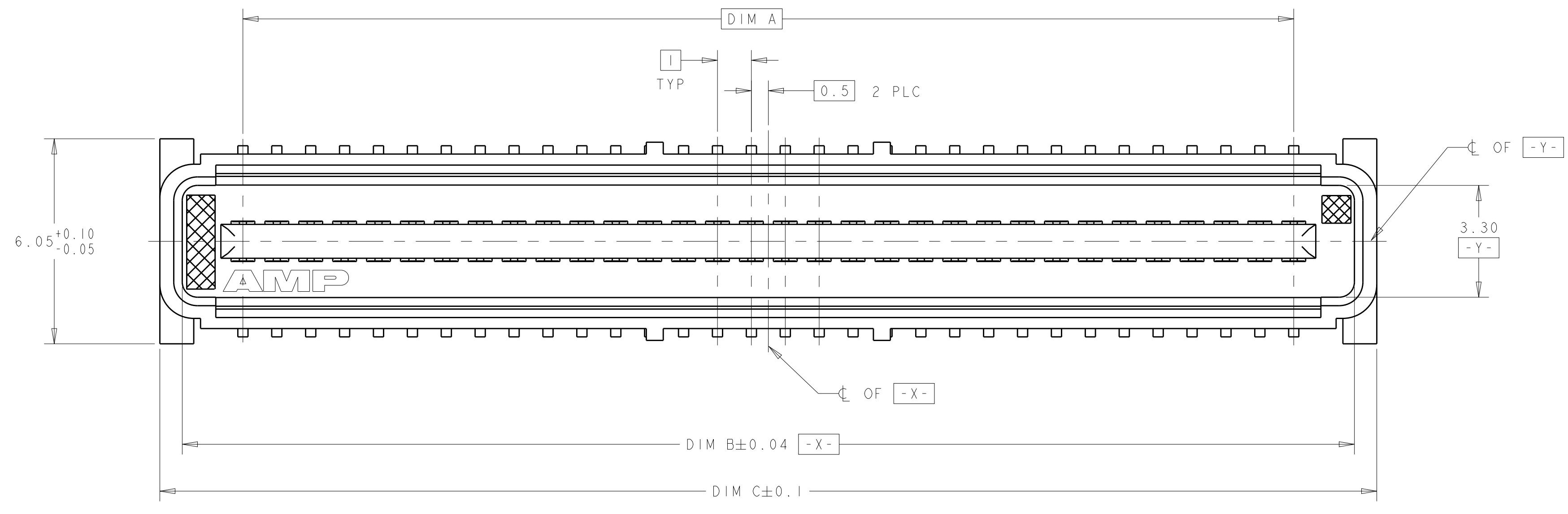

- 1 HOUSING MATERIAL: LIQUID CRYSTAL POLYMER. COLOR; BLACK. CONTACT MATERIAL: PHOSPHOR BRONZE.
- 2 CONTACT FINISH: NICKEL UNDERPLATE ALL OVER, MATING SURFACES PLATED TO MEET PL1 PERFORMANCE REQUIREMENTS OF INDUSTRY SPECIFICATION EIA-700AAAAB, SOLDER TAILS PLATED TIN-LEAD.
- 3 DATUM LOCATIONS AND BASIC DIMENSIONS TO BE ESTABLISHED BY THE CUSTOMER. CONSULT AMP ENGINEERING WHEN PLACING MULTIPLE CONNECTORS ON A PC BOARD.
- 4 PACKAGED IN TAPE ON REELS PER EIA-841.
- 5 1.5 MIN DIAMETER HOLE SHOULD BE USED IF USING POST STYLE "A" AND PLACING ON PCB WITH VACUUM PLACEMENT EQUIPMENT.
- 6 SHORTER SOLDER LANDS MAY BE USED PER EIA 700AAAAB, HOWEVER 2.7 LENGTH ASSURES OPTIMUM SOLDER FILLET.
- 7 CONTACT FINISH: 0.002 MINIMUM BRIGHT TIN-LEAD (93-7) ON SOLDER AREA, 0.00127 MINIMUM GOLD ON MATING AREA, BOTH OVER 0.00127 MINIMUM NICKEL ON ENTIRE CONTACT.
- 8 SQUARE AND DIAMOND SHAPED POSTS
- 9 ROUND SHAPED POSTS

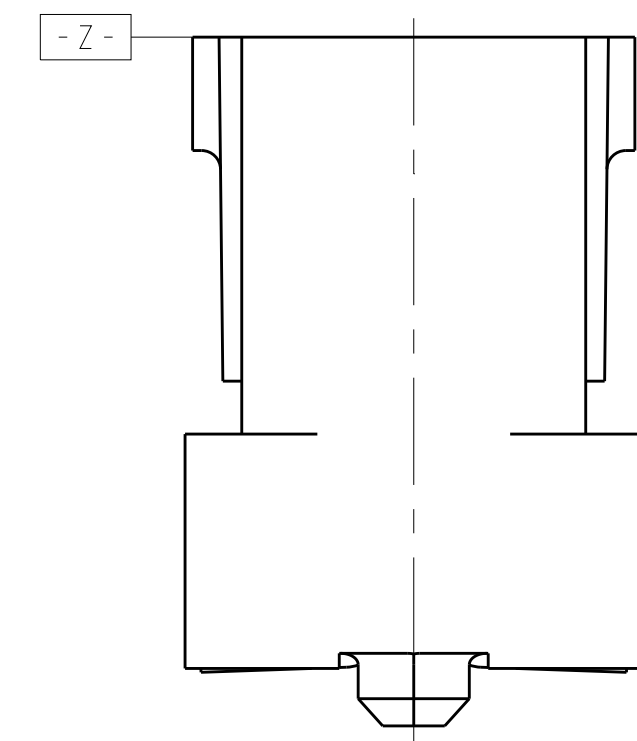
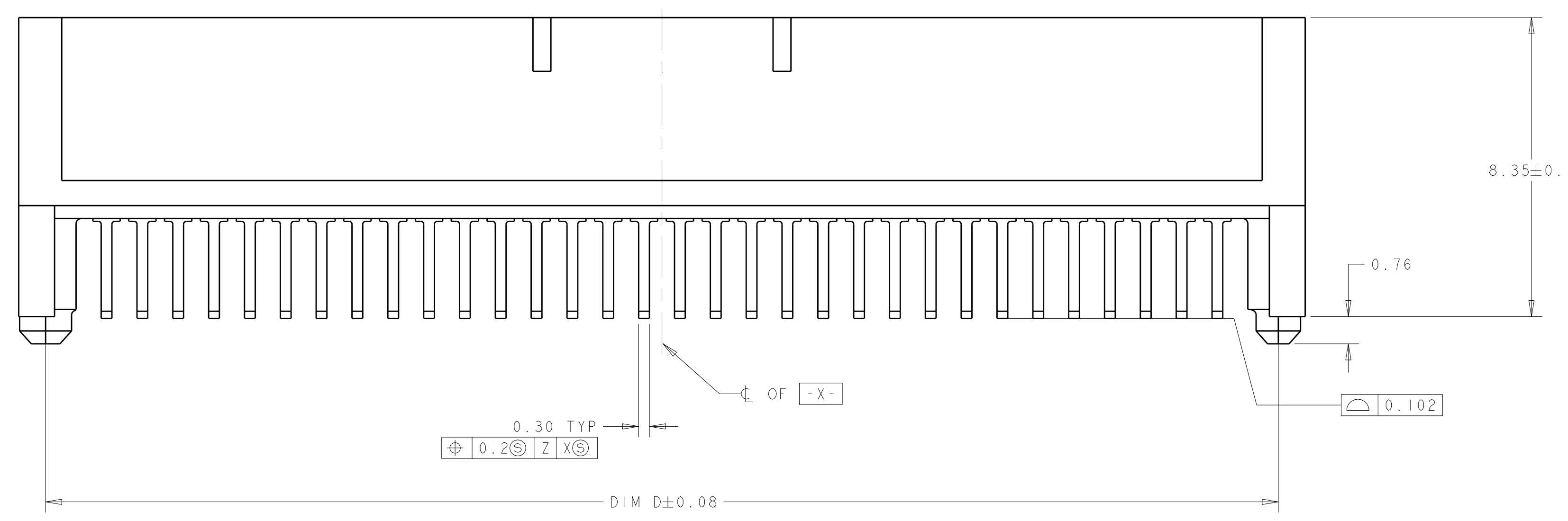

8 STYLE A POST

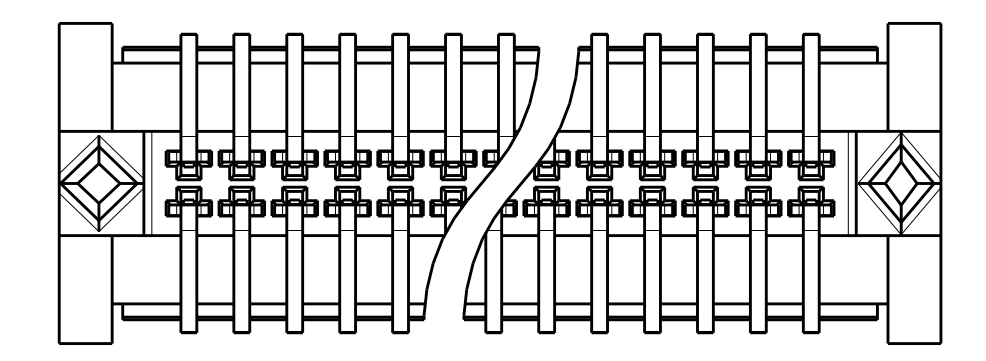

9 STYLE B POST

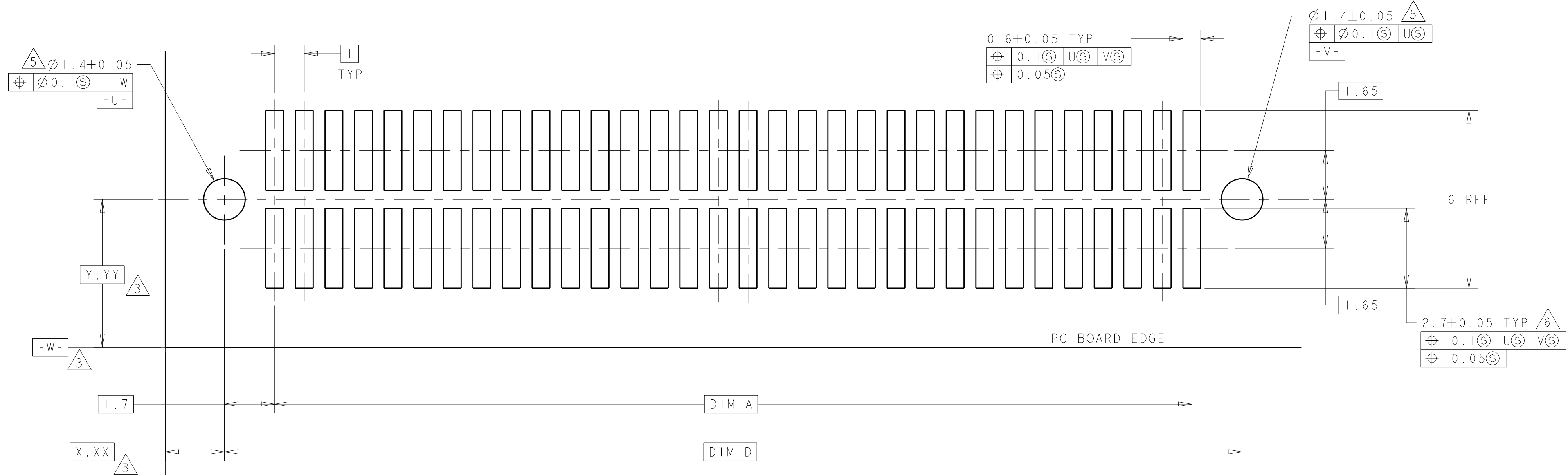
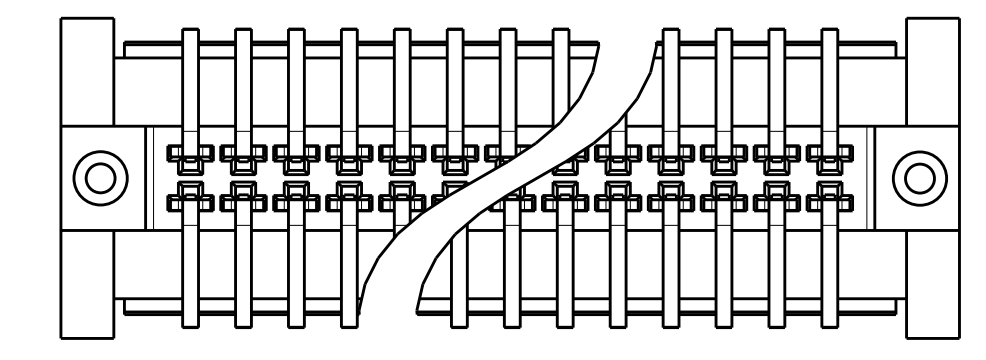

RECOMMENDED PC BOARD LAYOUT

POST STYLE	FINISH	DIM D	DIM C	DIM B	DIM A	STACK HGTS	POS	PART NO
9	7	44.4	45.9	44.58	41	10, 12, 13, 15	84	3-120527-2
9	7	34.4	35.9	34.58	31	10, 12, 13, 15	64	3-120527-1
9	2	44.4	45.9	44.58	41	10, 12, 13, 15	84	2-120527-2
9	2	34.4	35.9	34.58	31	10, 12, 13, 15	64	2-120527-1
8	7	44.4	45.9	44.58	41	10, 12, 13, 15	84	1-120527-2
8	7	34.4	35.9	34.58	31	10, 12, 13, 15	64	1-120527-1
8	2	44.4	45.9	44.58	41	10, 12, 13, 15	84	120527-2
8	2	34.4	35.9	34.58	31	10, 12, 13, 15	64	120527-1

THIS DRAWING IS A CONTROLLED DOCUMENT. DWN J. REED 17FEB1997
 CHK L. VO 17FEB1997
 APVD M. HORNUNG 25JAN2012

STE TE Connectivity

NAME PLUG ASSY, 1.0mm FH(IEEE 1386) CONNECTOR

PRODUCT SPEC 502-1079
 APPLICATION SPEC 114-25045

SIZE CAGE CODE DRAWING NO RESTRICTED TO
 A100779C=120527

MATERIAL FINISH SEE TABLE WEIGHT CUSTOMER DRAWING SCALE 10:1 SHEET 1 OF 1 REV F