

REVISIONS

P	LTR	DESCRIPTION	DATE	DWN	APVD
	M5	ECR-22-138429	18MAY2022	LP	DSC

AMP
WIRE RANGE

22-20 AWG
STRANDED

1 STAMP AMP 22-20 APPROX AS SHOWN

2 FOR 0.889[.035] TO 2.540[.100]
WIRE INSULATION DIA

3 BODY MATERIAL THK: 0.584±0.051[.023±.002]

4 DIMENSION APPLIES FROM EDGE OF METAL
WIRE BARREL TO CENTER OF STUD HOLE.

5 MATERIAL:
BODY & SLEEVE - COPPER PER ASTM B152
INSULATION - PTFE PER ASTM D4895

6 FINISH:
BODY - GOLD PLATE 0.00127[.00005] MIN EXT THK PER
ASTM B488 TYPE 1, CODE C OVER NICKEL PLATE
0.00076[.00003] AVG EXT THK PER SAE AMS-QQ-N-290
SLEEVE - NICKEL PLATE 0.001651[.000065] AVG EXT THK
PER SAE AMS-QQ-N-290
INSULATION COLOR - GREEN

7 NOTE DELETED

8 NOTE DELETED

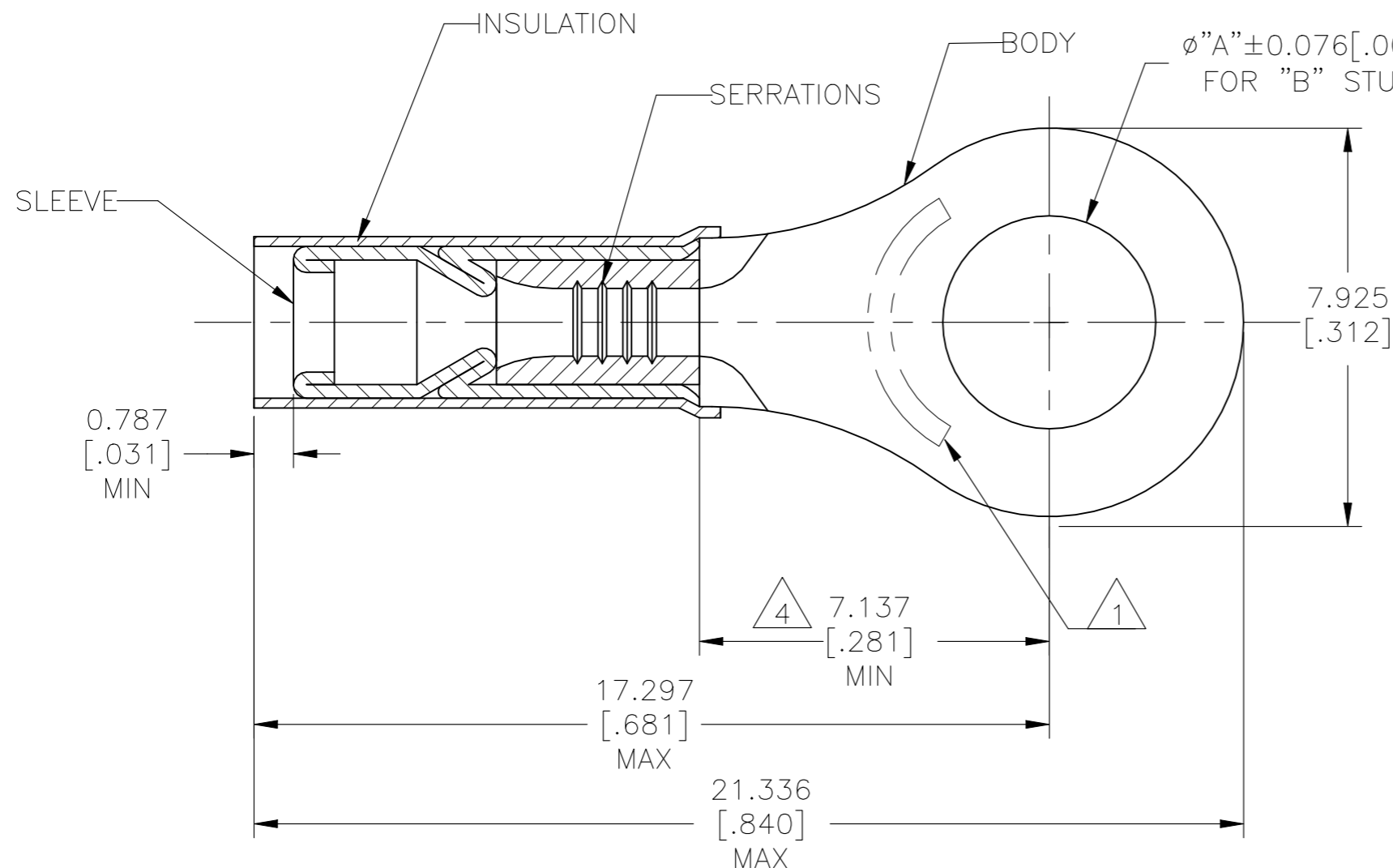

#10	5.004[.197]	1000	LOOSE PIECE	1-332434-0
M4[#8]	4.343[.171]	1000	LOOSE PIECE	332434
"B"	"A"	QTY	PACKAGE TYPE	PART NO.

AMP INCORPORATED CUSTOMER SERVICE SYSTEMS		MAX RECOMMENDED OPERATING TEMPERATURE: 260°C [500°F]	THIS DRAWING IS A CONTROLLED DOCUMENT.		DWN JR RUTH 28JAN03	STE TE Connectivity			
FOR ADDITIONAL PRODUCT INFORMATION OR COPIES OF DRAWINGS AND TECHNICAL DOCUMENTS	PRODUCT INFORMATION CENTER 1-800-522-6752	VOLTAGE RATING: 300V MAX	DIMENSIONS: mm [INCHES]	TOLERANCES UNLESS OTHERWISE SPECIFIED: 0 PLC ± - 1 PLC ± - 2 PLC ± 0.127 [.005] 3 PLC ± - 4 PLC ± - ANGLES ± 1°	CHK T MICHIELUTTI 28JAN03				
FOR APPLICATION TOOLING INFORMATION	TOOLING ASSISTANCE CENTER 1-800-722-1111	CIRCULAR MIL AREA: 0.26-0.65mm²[509-1,290] STRANDED WIRE ONLY		FINISH	APVD T MICHIELUTTI 28JAN03	PRODUCT SPEC			
FOR ORDER ENTRY	1-800-526-5142		MATERIAL		APPLICATION SPEC 114-2162	SIZE	CAGE CODE	DRAWING NO	RESTRICTED TO
					WEIGHT 0	A3	00779	C-332434	
					CUSTOMER DRAWING	SCALE 8:1	SHEET 1 OF 1	REV M5	