

NOTES:

1. MARKED WITH DEUTSCH PART No., DEUTSCH (HASTINGS) CAGE CODE AND DATE CODE.

PART NUMBER EXAMPLE: D369 - B 6 6 - N S 4

BASIC PART No. _____
SHELL STYLE (B = FLANGE MOUNT, 1.60MM PANEL (A)) _____
SHELL SIZE _____
CONTACT QTY (6 = 6 x #22's) _____

CONTACT CONFIGURATION (3)
CONTACT TYPE (S = SKT/FEMALE)
SHELL KEYING

2. PERFORMANCE:
TEMPERATURE RANGE: -55°C TO +175°C. INSULATION RESISTANCE: ≥5000 MΩ.
DIELECTRIC WITHSTAND: 1500VRMS, <2mA. SEALING: 15KM(50000FT) ALTITUDE / IP67
DURABILITY: 500 MATING CYCLES MIN. FLUID RESISTANCE: I.A.W. EN2591-315.
FLAMMABILITY, SMOKE AND TOXICITY: I.A.W. FAR 25.853 APPENDIX F.

3. CONTACT CONFIGURATION:
4 = GOLD PLATED CONTACTS, 90° PCB MOUNTING.
5 = GOLD PLATED CONTACTS, TIN DIPPED, 90° PCB MOUNTING.

4. MATERIALS:

COMPONENT	MATERIAL (FINISH: NONE UNLESS STATED)
SEALS / PANEL GASKET	SILICONE / FLUOROSILICONE BLEND RUBBER PER AMS-R-25988 TYPE II, CLASS I, GRADE 40
BODY / INSERT COMPONENTS	POLYETHERIMIDE, 10% GLASS FILLED PER ASTM D 5205

THESE CONNECTORS ARE ROHS COMPLIANT.

5. RECOMMENDED PANEL THICKNESS LISTED IN TABLE BELOW FOR REFERENCE ONLY. REFER TO INSTRUCTION SHEET 408-32194 FOR PANEL CUTOUT DIMENSIONS.

GASKET CONFIGURATION	NUMBER OF MARKS	RECOMMENDED PANEL THICKNESS	GASKET PART NUMBER
A	2	1.27	612154-6-A
B	3	1.60	612154-6-B
C	4	2.03	612154-6-C

6. MAXIMUM WEIGHT: 7.7g

AC	DUK-68100	LPM	RJM	GDM	CEO	16/05/2017
ISSUE	CHANGE NOTE	DRAWN	CHECKED	APP. ENG.	APP. MARKETING	DATE

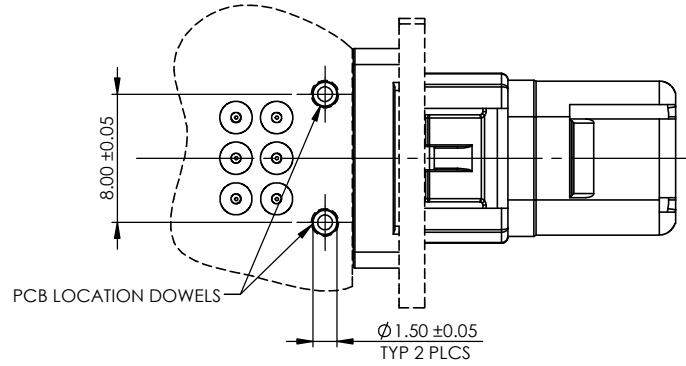
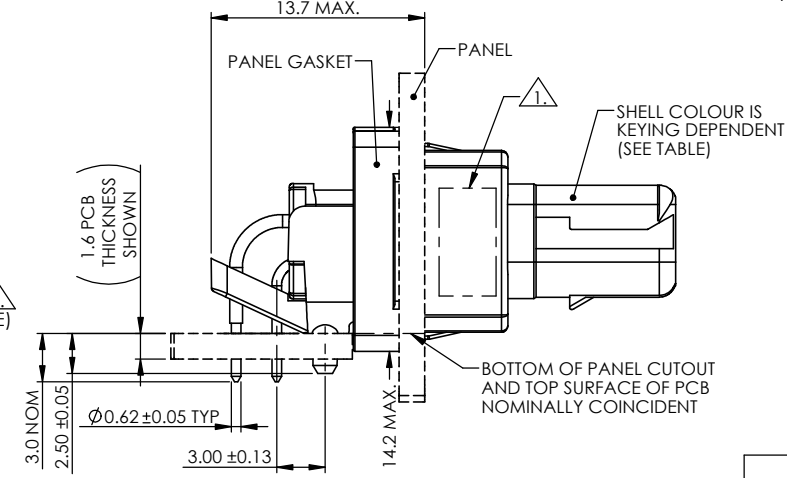

HOLE TABLE			
HOLE TYPE	CO-ORDINATES		HOLE POSITION TOLERANCE
	'X'	'Y'	
PCB LOCATION HOLES	+3.00 REF	+4.00 REF	Ø 0.10
	+3.00 REF	-4.00 REF	
CONTACT TAIL HOLES	LOCATION	-	HOLE DIAMETER AND TOLERANCE AND HOLE POSITION TOLERANCES TO SUIT CUSTOMER PCB DESIGN GUIDELINES
	1	-2.54	
	2	-2.54	
	3	-2.54	
	4	0	
	5	0	
6	0	-2.54	

KEYING TABLE	
ORIENTATION	COLOUR
N	BLACK
A	DARK RED
B	DARK BLUE
C	DARK GREEN
D	YELLOW

MATERIAL	
SEE TABLE	
HEAT TREATMENT & FINISH	
SEE TABLE	
PACKAGING	
SCALE	3:1
DIMENSIONS IN MILLIMETRES UNLESS OTHERWISE STATED	

THIS INFORMATION IS CONFIDENTIAL AND PROPRIETARY TO TYCO ELECTRONICS CORPORATION AND ITS WORLDWIDE SUBSIDIARIES AND AFFILIATES (TE). IT MAY NOT BE DISCLOSED TO ANYONE, OTHER THAN TE PERSONNEL, WITHOUT AUTHORIZATION FROM TE (www.TE.com).

TITLE: D369 PANEL MOUNT PCB RECEPTACLE. 6 WAY SKT/FEMALE. ENVELOPE.

ST LEONARDS ON SEA, EAST SUSSEX, TN38 9RF
TEL. +44 (0)1424 852721

DRAWING NUMBER: 612229-6S-ENV