

Pressure click™

1. Introduction

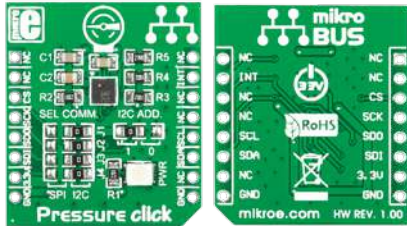

Pressure Click™ is an accessory board in **mikroBUS™** form factor. It's a compact and easy solution for adding pressure measurement to your design. It features **LPS331AP** digital output pressure sensor. Pressure Click™ communicates with the target board microcontroller via **mikroBUS™** SPI (MOSI, MISO, SCK, CS), I²C (SDA, SCL) and INT lines. The board is designed to use 3.3V power supply only. LED diode (GREEN) indicates the presence of power supply.

2. Soldering the headers

Before using your click board™, make sure to solder 1x8 male headers to both left and right side of the board. Two 1x8 male headers are included with the board in the package.

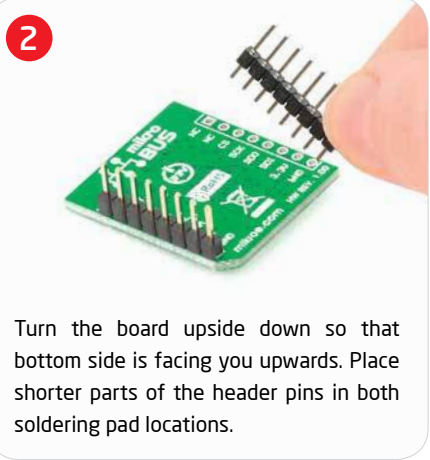

Turn the board upside down so that bottom side is facing you upwards. Place shorter parts of the header pins in both soldering pad locations.

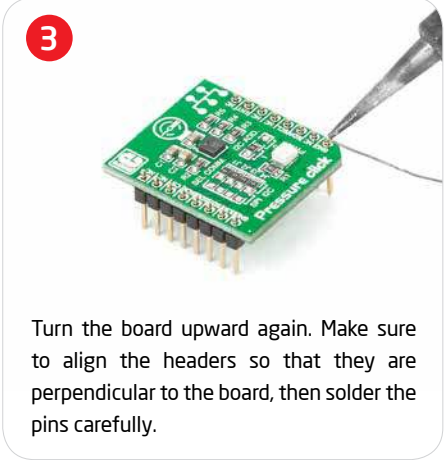

Turn the board upward again. Make sure to align the headers so that they are perpendicular to the board, then solder the pins carefully.



3. Plugging the board in

Once you have soldered the headers your board is ready to be placed into desired mikroBUS™ socket. Make sure to align the cut in the lower-right part of the board with the markings on the silkscreen at the mikroBUS™ socket. If all of the pins are aligned correctly, push the board all the way into the socket.

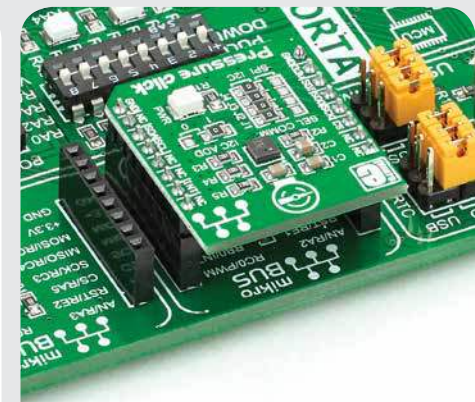

4. Essential features

Pressure Click™ with its **LPS331AP** IC is an ultra compact absolute piezoresistive pressure sensor capable to measure pressure (260-1260 mbar) or temperature (-40°C to 80°C) and provide a digital signal to main board microcontroller. All these features make this board ideal for indoor and outdoor navigations, altimeter or barometer for portable devices, weather station equipment, sport watches and many more.



5. Pressure Click™ Board Schematic

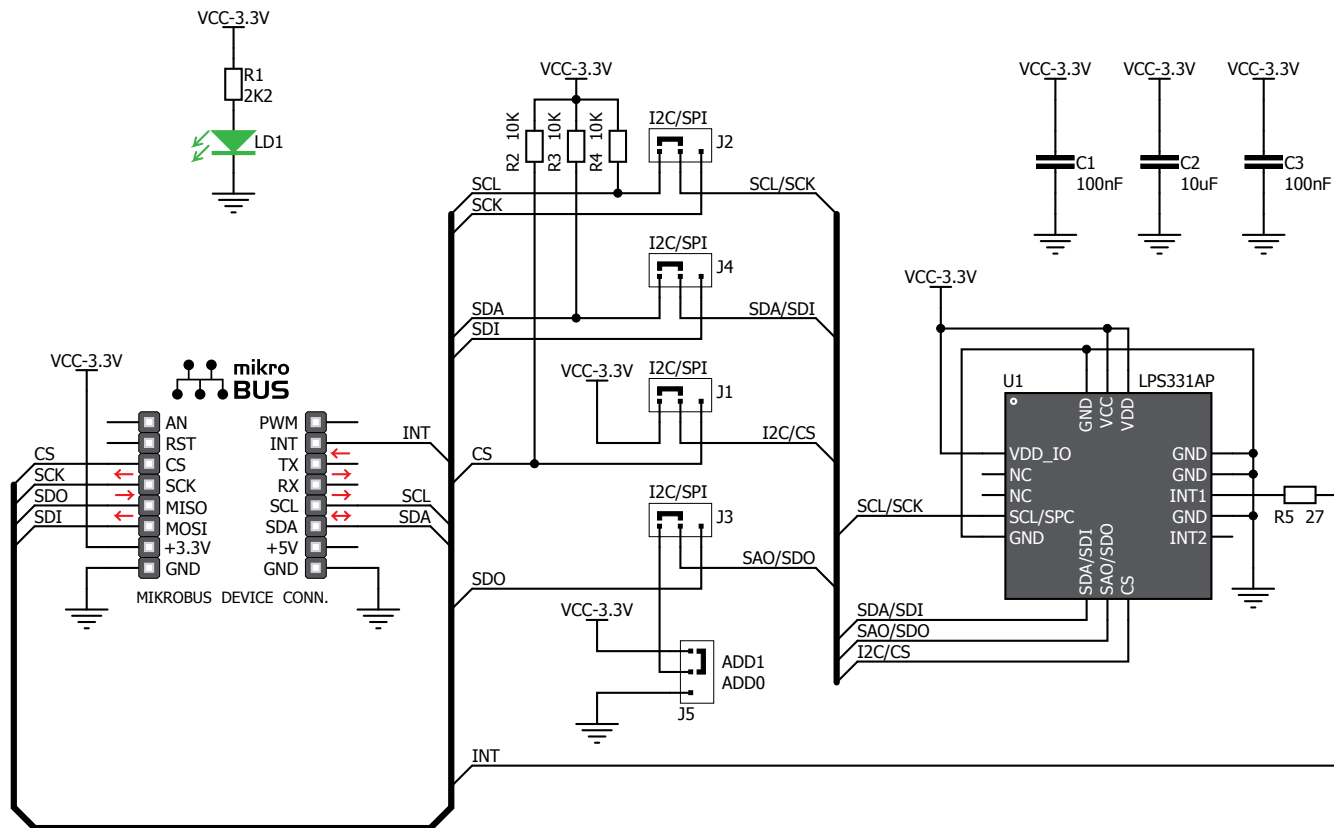

6. SMD Jumpers



The Pressure Click™ board communicates with the main board microcontroller via I²C or SPI interface depending on the position of the **J1**, **J2**, **J3** and **J4** SMD jumpers. These jumpers are soldered in I²C interface position by default. There is an option to select the alternate address with jumper **J5** in the case of I²C interface (default position is logic 1).

7. Code Examples

Once you have done all the necessary preparations, it's time to get your click board up and running. We have provided the examples for mikroC, mikroBasic and mikroPascal compilers on our **Libstock** website. Just download them and you are ready to start.



8. Support

MikroElektronika offers **Free Tech Support** (www.mikroe.com/esupport) until the end of product lifetime, so if something goes wrong, we are ready and willing to help!