

- 1
- 2
- 3
- 4
- 5
- 6
- 7
- 8
- 9
- 10
- 11
- 12
- 13
- 14
- 15
- 16
- 17
- 18

MATERIAL

Glass-fibre reinforced polyamide-based (PA) technopolymer, grey colour.

STANDARD EXECUTIONS

- **ZCL-0.5:** module 0.5, non-drilled hub (for number of teeth $Z \leq 50$) or pre-drilled pass-through hole (for number of teeth $Z \geq 55$).
- **ZCL-1.0:** module 1.0, non-drilled hub (for number of teeth $Z = 10$) or pre-drilled pass-through hole.
- **ZCL-1.5:** module 1.5, pre-drilled pass-through hole
- **ZCL-2.0:** module 2.0, pre-drilled pass-through hole
- **ZCL-2.5:** module 2.5, pre-drilled pass-through hole.
- **ZCL-3.0:** module 3.0, pre-drilled pass-through hole.
- **ZCL-1.0-K:** module 1.0, drilled hub with keyway UNI 6604 (see page A-16), D10 tolerance.
- **ZCL-1.5-K:** module 1.5, drilled hub with keyway UNI 6604 (see page A-16), D10 tolerance.
- **ZCL-2.0-K:** module 2.0, drilled hub with keyway UNI 6604 (see page A-16), D10 tolerance.
- **ZCL-2.5-K:** module 2.5, drilled hub with keyway UNI 6604 (see page A-16), D10 tolerance.
- **ZCL-3.0-K:** module 3.0, drilled hub with keyway UNI 6604 (see page A-16), D10 tolerance.

For operations with the pre-drilled pass-through hole, in the table the size "d" of the hole represents the minimum diameter of the hole that can be obtained through machining.

FEATURES

The torques indicated in the tables are granted with rpm included between 0 and 150. Torque values can vary depending on lubrication, temperature, pairing with different materials and continuous operating hours.

Maximum tolerance on plain pass-through hole: IT 9.

TECHNICAL DATA

See: Transmission elements (on page -).



SPECIAL EXECUTIONS ON REQUEST

- Assembly by means of a transversal grub screw.
- Various non-standard gears with hub with keyway according to UNI 6604 tolerance D10.

MOUNTING

To pair two spur gears, a positive backlash must be considered. For modules 0.5 - 1.0 - 1.5 is recommended the tolerance (+0.03 +0.1). For modules 2.0 - 2.5 - 3.0 is recommended the tolerance (+0.08 +0.3).

Conversion Table	
1 mm = 0.039 inch	
mm	inch
16	0.63
25	0.98
30	1.18
35	1.38
40	1.57
45	1.77

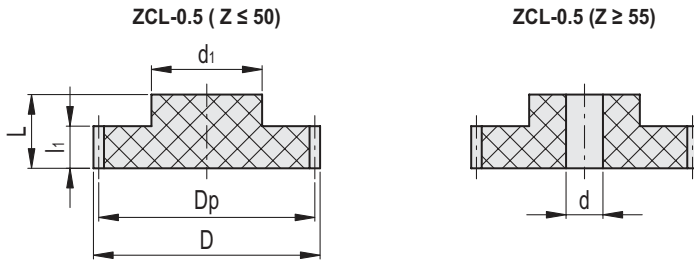

ZCL-0.5

METRIC

Code	Description	Module M	No. of teeth Z	Dp*	D	L	d	d1	l1	Max. torque [Nm]	⚖️
550011	ZCL-0.5-24	0.5	24	12	13	16	-	10	8	0.8	2
550013	ZCL-0.5-25	0.5	25	12.5	13.5	16	-	10	8	0.8	2
550015	ZCL-0.5-30	0.5	30	15	16	16	-	10	8	1.0	3
550017	ZCL-0.5-32	0.5	32	16	17	16	-	10	8	1.0	3
550019	ZCL-0.5-36	0.5	36	18	19	16	-	10	8	1.2	4
550021	ZCL-0.5-40	0.5	40	20	21	16	-	10	8	1.3	4
550023	ZCL-0.5-45	0.5	45	22.5	23.5	16	-	10	8	1.5	5
550025	ZCL-0.5-48	0.5	48	24	25	16	-	10	8	1.6	6
550027	ZCL-0.5-50	0.5	50	25	26	16	-	10	8	1.6	6
550029	ZCL-0.5-55	0.5	55	27.5	28.5	16	4	20	8	1.8	8
550031	ZCL-0.5-60	0.5	60	30	31	16	4	20	8	2.0	11
550033	ZCL-0.5-70	0.5	70	35	36	16	4	20	8	2.3	13
550035	ZCL-0.5-80	0.5	80	40	41	16	4	20	8	2.6	17

Conversion Table
1 mm = 0.039 inch

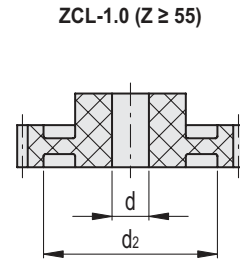
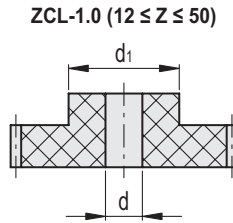
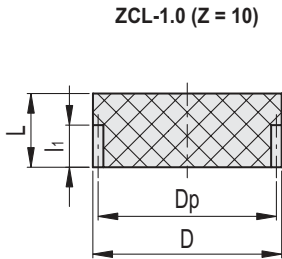

ZCL-1.0

METRIC

Code	Description	Module M	No. of teeth Z	Dp*	D	L	d	d1	d2	l1	Max. torque [Nm]	⚖️
550101	ZCL-1.0-10	1.0	10	10	12	25	-	-	-	15	2.5	2
550103	ZCL-1.0-12	1.0	12	12	14	25	4	9	-	15	2.9	3
550107	ZCL-1.0-14	1.0	14	14	16	25	4	10	-	15	3.4	4
550109	ZCL-1.0-15	1.0	15	15	17	25	4	10	-	15	3.7	4
550111	ZCL-1.0-16	1.0	16	16	18	25	5	13	-	15	3.9	5
550115	ZCL-1.0-18	1.0	18	18	20	25	5	14	-	15	4.4	6
550119	ZCL-1.0-20	1.0	20	20	22	25	5	16	-	15	4.9	8
550121	ZCL-1.0-21	1.0	21	21	23	25	5	16	-	15	5.2	9
550123	ZCL-1.0-22	1.0	22	22	24	25	5	18	-	15	5.4	9
550127	ZCL-1.0-24	1.0	24	24	26	25	6	20	-	15	5.9	12
550129	ZCL-1.0-25	1.0	25	25	27	25	6	20	-	15	6.1	12
550131	ZCL-1.0-26	1.0	26	26	28	25	6	22	-	15	6.4	13
550133	ZCL-1.0-27	1.0	27	27	29	25	6	22	-	15	6.6	15
550135	ZCL-1.0-28	1.0	28	28	30	25	6	22	-	15	6.9	15
550139	ZCL-1.0-30	1.0	30	30	32	25	6	25	-	15	7.4	18
550143	ZCL-1.0-32	1.0	32	32	34	25	6	25	-	15	7.9	19
550145	ZCL-1.0-33	1.0	33	33	35	25	6	25	-	15	8.1	20
550147	ZCL-1.0-34	1.0	34	34	36	25	8	30	-	15	8.4	24
550149	ZCL-1.0-35	1.0	35	35	37	25	8	30	-	15	8.6	24
550151	ZCL-1.0-36	1.0	36	36	38	25	8	30	-	15	8.8	28
550155	ZCL-1.0-38	1.0	38	38	40	25	8	30	-	15	9.3	28
550157	ZCL-1.0-39	1.0	39	39	41	25	8	30	-	15	9.6	28
550159	ZCL-1.0-40	1.0	40	40	42	25	8	30	-	15	9.8	29
550163	ZCL-1.0-42	1.0	42	42	44	25	10	35	-	15	10.3	35
550167	ZCL-1.0-44	1.0	44	44	46	25	10	35	-	15	10.8	36
550169	ZCL-1.0-45	1.0	45	45	47	25	10	35	-	15	11.1	37
550173	ZCL-1.0-48	1.0	48	48	50	25	10	35	-	15	11.8	42
550177	ZCL-1.0-50	1.0	50	50	52	25	10	35	-	15	12.3	45
550183	ZCL-1.0-55	1.0	55	55	57	25	14	35	44	15	13.5	45
550187	ZCL-1.0-58	1.0	58	58	60	25	14	35	44	15	14.3	49
550189	ZCL-1.0-60	1.0	60	60	62	25	14	40	51	15	14.7	58
550195	ZCL-1.0-65	1.0	65	65	67	25	20	40	51	15	16.0	60
550197	ZCL-1.0-70	1.0	70	70	72	25	20	40	61	15	17.2	71
550201	ZCL-1.0-72	1.0	72	72	74	25	20	40	61	15	17.7	78
550205	ZCL-1.0-74	1.0	74	74	76	25	20	40	61	15	18.2	72
550207	ZCL-1.0-75	1.0	75	75	77	25	20	50	66	15	18.4	74
550209	ZCL-1.0-77	1.0	77	77	79	25	20	50	66	15	18.9	90
550211	ZCL-1.0-80	1.0	80	80	82	25	20	50	66	15	19.7	97

* Pitch diameter.



Conversion Table
1 mm = 0.039 inch

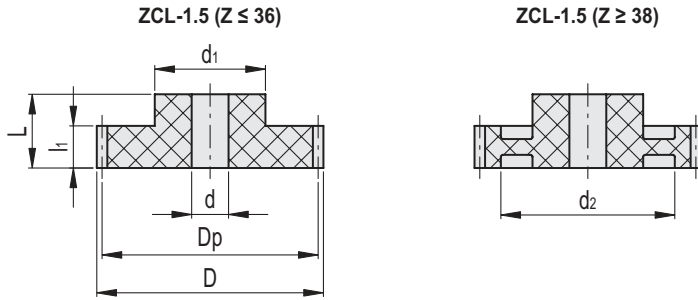

METRIC

ZCL-1.5

Code	Description	Module M	No. of teeth Z	Dp*	D	L	d	d1	d2	l1	Max. torque [Nm]	⚖️
550301	ZCL-1.5-12	1.5	12	18	21	30	5	14	-	17	8.2	7
550305	ZCL-1.5-14	1.5	14	21	24	30	5	16	-	17	9.6	10
550307	ZCL-1.5-15	1.5	15	22.5	25.5	30	5	18	-	17	10.3	13
550309	ZCL-1.5-16	1.5	16	24	27	30	5	18	-	17	10.9	13
550313	ZCL-1.5-18	1.5	18	27	30	30	6	20	-	17	12.3	16
550317	ZCL-1.5-20	1.5	20	30	33	30	8	25	-	17	13.7	23
550319	ZCL-1.5-21	1.5	21	31.5	34.5	30	8	25	-	17	14.4	25
550321	ZCL-1.5-22	1.5	22	33	36	30	8	28	-	17	15.0	25
550325	ZCL-1.5-24	1.5	24	36	39	30	8	28	-	17	16.4	28
550327	ZCL-1.5-25	1.5	25	37.5	40.5	30	8	30	-	17	17.1	34
550329	ZCL-1.5-26	1.5	26	39	42	30	8	30	-	17	17.8	35
550333	ZCL-1.5-28	1.5	28	42	45	30	8	30	-	17	19.1	39
550337	ZCL-1.5-30	1.5	30	45	48	30	12	35	-	17	20.5	45
550341	ZCL-1.5-32	1.5	32	48	51	30	12	35	-	17	21.9	49
550343	ZCL-1.5-33	1.5	33	49.5	52.5	30	12	35	-	17	22.6	55
550345	ZCL-1.5-34	1.5	34	51	54	30	12	35	-	17	23.2	54
550347	ZCL-1.5-35	1.5	35	52.5	55.5	30	12	35	-	17	23.9	61
550349	ZCL-1.5-36	1.5	36	54	57	30	12	35	-	17	24.6	48
550353	ZCL-1.5-38	1.5	38	57	60	30	16	35	42	17	26.0	53
550355	ZCL-1.5-39	1.5	39	58.5	61.5	30	16	35	42	17	26.7	61
550357	ZCL-1.5-40	1.5	40	60	63	30	16	40	48	17	27.4	64
550359	ZCL-1.5-42	1.5	42	63	66	30	16	45	53	17	28.7	72
550363	ZCL-1.5-44	1.5	44	66	69	30	16	45	53	17	30.1	84
550365	ZCL-1.5-45	1.5	45	67.5	70.5	30	16	45	53	17	30.8	85
550367	ZCL-1.5-46	1.5	46	69	72	30	16	45	53	17	31.5	86
550371	ZCL-1.5-48	1.5	48	75	75	30	16	45	53	17	32.8	99
550373	ZCL-1.5-50	1.5	50	75	78	30	16	45	53	17	34.2	111
550375	ZCL-1.5-51	1.5	51	76.5	79.5	30	20	50	63	17	34.9	110
550377	ZCL-1.5-52	1.5	52	78	81	30	20	50	63	17	35.6	113
550381	ZCL-1.5-54	1.5	54	81	84	30	20	50	63	17	36.9	122
550383	ZCL-1.5-55	1.5	55	82.5	85.5	30	20	50	63	17	37.6	126
550385	ZCL-1.5-60	1.5	60	90	93	30	20	55	73	17	41.0	147
550389	ZCL-1.5-65	1.5	65	97.5	100.5	30	20	60	81	17	44.4	175
550391	ZCL-1.5-70	1.5	70	105	108	30	20	60	93	17	47.9	137
550393	ZCL-1.5-75	1.5	75	112.5	115.5	30	20	60	93	17	51.3	155
550395	ZCL-1.5-80	1.5	80	120	123	30	20	60	109	17	54.7	170

Standard machine parts

* Pitch diameter.

Conversion Table
1 mm = 0.039 inch

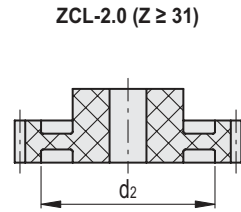
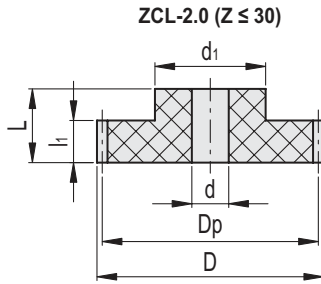

ZCL-2.0

METRIC

Code	Description	Module M	No. of teeth Z	Dp*	D	L	d	d1	d2	l1	Max. torque [Nm]	⚖️
550501	ZCL-2.0-12	2.0	12	24	28	35	8	18	-	20	18.6	15
550503	ZCL-2.0-13	2.0	13	26	30	35	8	18	-	20	20.1	17
550505	ZCL-2.0-14	2.0	14	28	32	35	8	20	-	20	21.7	20
550507	ZCL-2.0-15	2.0	15	30	34	35	8	22	-	20	23.2	23
550509	ZCL-2.0-16	2.0	16	32	36	35	8	25	-	20	24.8	29
550511	ZCL-2.0-17	2.0	17	34	38	35	8	25	-	20	26.3	31
550513	ZCL-2.0-18	2.0	18	36	40	35	10	30	-	20	27.9	34
550515	ZCL-2.0-19	2.0	19	38	42	35	10	30	-	20	29.4	40
550517	ZCL-2.0-20	2.0	20	40	44	35	10	30	-	20	31.0	42
550519	ZCL-2.0-21	2.0	21	42	46	35	10	30	-	20	32.5	46
550521	ZCL-2.0-22	2.0	22	44	48	35	10	30	-	20	34.1	49
550523	ZCL-2.0-23	2.0	23	46	50	35	10	35	-	20	35.6	60
550525	ZCL-2.0-24	2.0	24	48	52	35	10	35	-	20	37.2	56
550527	ZCL-2.0-25	2.0	25	50	54	35	10	35	-	20	38.7	66
550529	ZCL-2.0-26	2.0	26	52	56	35	14	40	-	20	40.3	71
550531	ZCL-2.0-27	2.0	27	54	58	35	14	40	-	20	41.8	71
550533	ZCL-2.0-28	2.0	28	56	60	35	14	40	-	20	43.4	74
550535	ZCL-2.0-29	2.0	29	58	62	35	14	40	-	20	44.9	86
550537	ZCL-2.0-30	2.0	30	60	64	35	14	40	-	20	46.5	83
550539	ZCL-2.0-31	2.0	31	62	66	35	14	40	48	20	48.0	87
550541	ZCL-2.0-32	2.0	32	64	68	35	16	45	51	20	49.6	95
550543	ZCL-2.0-33	2.0	33	66	70	35	16	45	51	20	51.1	98
550545	ZCL-2.0-34	2.0	34	68	72	35	16	45	51	20	52.7	105
550547	ZCL-2.0-35	2.0	35	70	74	35	16	45	51	20	54.2	113
550549	ZCL-2.0-36	2.0	36	72	76	35	16	50	59	20	55.8	115
550551	ZCL-2.0-37	2.0	37	74	78	35	16	50	59	20	57.3	118
550553	ZCL-2.0-38	2.0	38	76	80	35	16	50	59	20	58.9	125
550555	ZCL-2.0-39	2.0	39	78	82	35	16	50	59	20	60.4	127
550557	ZCL-2.0-40	2.0	40	80	84	35	16	55	66	20	62.0	138
550561	ZCL-2.0-42	2.0	42	84	88	35	16	55	66	20	65.1	156
550565	ZCL-2.0-44	2.0	44	88	92	35	16	60	68	20	68.2	175
550567	ZCL-2.0-45	2.0	45	90	94	35	16	60	68	20	69.7	177
550569	ZCL-2.0-46	2.0	46	92	96	35	16	60	75	20	71.3	181
550573	ZCL-2.0-48	2.0	48	96	100	35	16	60	75	20	74.4	193
550577	ZCL-2.0-50	2.0	50	100	104	35	20	60	84	20	77.5	209
550581	ZCL-2.0-52	2.0	52	104	108	35	20	60	90	20	80.6	203
550585	ZCL-2.0-54	2.0	54	108	112	35	20	60	90	20	83.7	211
550591	ZCL-2.0-57	2.0	57	114	118	35	20	60	90	20	88.3	208
550597	ZCL-2.0-60	2.0	60	120	124	35	20	60	101	20	93.0	238
550601	ZCL-2.0-62	2.0	62	124	128	35	20	60	101	20	96.1	257
550605	ZCL-2.0-64	2.0	64	128	132	35	20	60	101	20	99.2	276
550607	ZCL-2.0-65	2.0	65	130	134	35	20	60	101	20	100.7	226
550609	ZCL-2.0-66	2.0	66	132	136	35	20	60	101	20	102.3	295
550613	ZCL-2.0-68	2.0	68	136	140	35	20	60	101	20	105.3	265
550617	ZCL-2.0-70	2.0	70	140	144	35	20	60	117	20	108.4	274
550621	ZCL-2.0-72	2.0	72	144	148	35	20	60	117	20	111.5	324
550625	ZCL-2.0-74	2.0	74	148	152	35	20	60	117	20	114.6	340
550627	ZCL-2.0-75	2.0	75	150	154	35	20	60	117	20	116.2	349
550629	ZCL-2.0-76	2.0	76	152	156	35	20	60	117	20	117.7	376
550633	ZCL-2.0-78	2.0	78	156	160	35	20	60	117	20	120.8	381
550637	ZCL-2.0-80	2.0	80	160	164	35	20	60	117	20	123.9	292
550657	ZCL-2.0-90	2.0	90	180	184	35	20	60	147	20	139.4	451
550677	ZCL-2.0-100	2.0	100	200	204	35	25	60	183	20	154.9	384

* Pitch diameter.



Conversion Table
1 mm = 0.039 inch

ZCL-2.5 (Z ≤ 26)

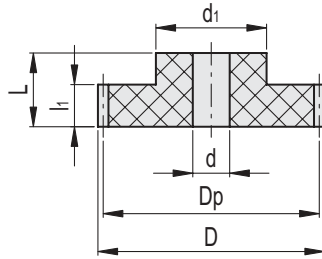

ZCL-2.5 (Z ≥ 27)

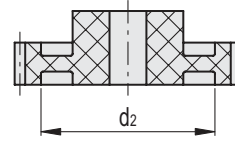

METRIC

ZCL-2.5

Code	Description	Module M	No. of teeth Z	Dp*	D	L	d	d1	d2	l1	Max. torque [Nm]	⚖️
550701	ZCL-2.5-12	2.5	12	30	35	40	8	22	-	25	36.3	26
550703	ZCL-2.5-14	2.5	14	35	40	40	8	22	-	25	42.4	38
550705	ZCL-2.5-15	2.5	15	37.5	42.5	40	10	30	-	25	45.4	45
550707	ZCL-2.5-16	2.5	16	40	45	40	10	30	-	25	48.4	46
550711	ZCL-2.5-18	2.5	18	45	50	40	10	35	-	25	54.5	61
550715	ZCL-2.5-20	2.5	20	50	55	40	10	35	-	25	60.5	73
550719	ZCL-2.5-22	2.5	22	55	60	40	16	40	-	25	66.6	90
550721	ZCL-2.5-23	2.5	23	57.5	62.5	40	16	40	-	25	69.6	90
550723	ZCL-2.5-24	2.5	24	60	65	40	16	40	-	25	72.6	96
550725	ZCL-2.5-25	2.5	25	62.5	67.5	40	16	40	-	25	75.6	109
550727	ZCL-2.5-26	2.5	26	65	70	40	16	40	-	25	78.7	75
550729	ZCL-2.5-27	2.5	27	67.5	72.5	40	16	40	50	25	81.7	121
550731	ZCL-2.5-28	2.5	28	70	75	40	16	40	50	25	84.7	131
550733	ZCL-2.5-29	2.5	29	72.5	77.5	40	16	45	56	25	87.8	141
550735	ZCL-2.5-30	2.5	30	75	80	40	16	45	56	25	90.8	147
550739	ZCL-2.5-32	2.5	32	80	85	40	16	50	61	25	96.8	171
550745	ZCL-2.5-35	2.5	35	87.5	92.5	40	16	50	61	25	105.9	172
550755	ZCL-2.5-40	2.5	40	100	105	40	18	50	73	25	121.0	233
550761	ZCL-2.5-45	2.5	45	112.5	117.5	40	18	60	85	25	136.2	298
550763	ZCL-2.5-50	2.5	50	125	130	40	20	60	105	25	151.3	299

ZCL-3.0

Code	Description	Module M	No. of teeth Z	Dp*	D	L	d	d1	d2	l1	Max. torque [Nm]	⚖️
550801	ZCL-3.0-12	3.0	12	36	42	45	12	25	-	30	62.7	43
550805	ZCL-3.0-14	3.0	14	42	48	45	12	30	-	30	73.2	61
550807	ZCL-3.0-15	3.0	15	45	51	45	12	30	-	30	78.4	70
550809	ZCL-3.0-16	3.0	16	48	54	45	12	35	-	30	83.7	82
550813	ZCL-3.0-18	3.0	18	54	60	45	12	40	-	30	94.1	109
550817	ZCL-3.0-20	3.0	20	60	66	45	12	45	-	30	104.6	135
550821	ZCL-3.0-22	3.0	22	66	72	45	16	45	-	30	115.0	156
550823	ZCL-3.0-23	3.0	23	69	75	45	16	45	-	30	120.3	169
550825	ZCL-3.0-24	3.0	24	72	78	45	16	45	-	30	125.5	180
550827	ZCL-3.0-25	3.0	25	75	81	45	16	45	-	30	130.7	175
550829	ZCL-3.0-26	3.0	26	78	84	45	16	45	-	30	135.9	205
550831	ZCL-3.0-27	3.0	27	81	87	45	16	45	-	30	141.2	224
550833	ZCL-3.0-28	3.0	28	84	90	45	16	50	65	30	146.4	207
550835	ZCL-3.0-29	3.0	29	87	93	45	16	50	65	30	151.6	220
550837	ZCL-3.0-30	3.0	30	90	96	45	16	50	65	30	156.9	236
550841	ZCL-3.0-32	3.0	32	96	102	45	16	50	73	30	167.3	243
550845	ZCL-3.0-35	3.0	35	105	111	45	20	60	80	30	183.0	315
550855	ZCL-3.0-40	3.0	40	120	126	45	20	60	85	30	209.1	322
550865	ZCL-3.0-45	3.0	45	135	141	45	20	60	101	30	235.3	434
550875	ZCL-3.0-50	3.0	50	150	156	45	20	60	127	30	261.4	400

Standard machine parts

* Pitch diameter.

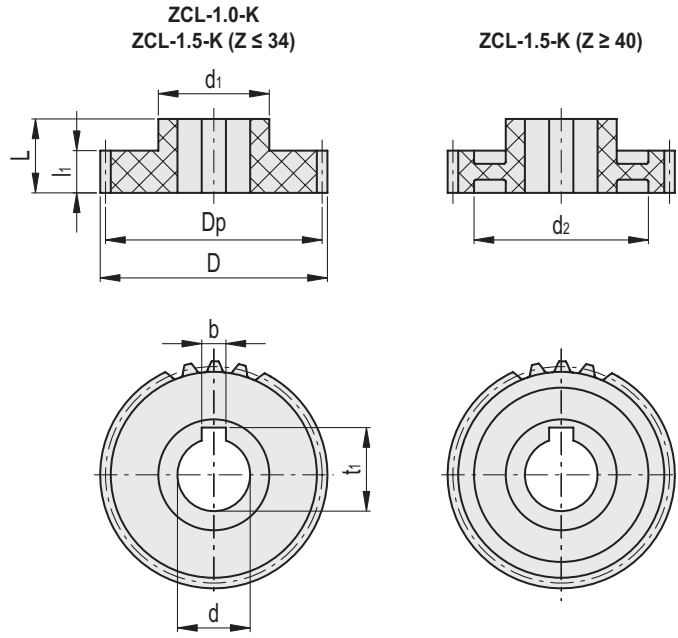

Conversion Table	
1 mm = 0.039 inch	
L	
mm	inch
25	0.98
30	1.18

ZCL-1.0-K

METRIC

Code	Description	Module M	No. of teeth Z	Dp*	D	L	dH9	bD10	t1	d1	l1	Max. torque [Nm]	
550119-K	ZCL-1.0-20-A8-K	1.0	20	20	22	25	8	2	9 +0.1	16	15	4.9	8
550123-K	ZCL-1.0-22-A10-K	1.0	22	22	24	25	10	3	11.4 +0.1	18	15	5.4	9
550127-K	ZCL-1.0-24-A10-K	1.0	24	24	26	25	10	3	11.4 +0.1	20	15	5.9	12
550129-K	ZCL-1.0-25-A10-K	1.0	25	25	27	25	10	3	11.4 +0.1	20	15	6.1	12
550139-K	ZCL-1.0-30-A12-K	1.0	30	30	32	25	12	4	13.8 +0.1	25	15	7.4	18
550143-K	ZCL-1.0-32-A12-K	1.0	32	32	34	25	12	4	13.8 +0.1	25	15	7.9	19
550147-K	ZCL-1.0-34-A12-K	1.0	34	34	36	25	12	4	13.8 +0.1	30	15	8.4	24
550149-K	ZCL-1.0-35-A12-K	1.0	35	35	37	25	12	4	13.8 +0.1	30	15	8.6	24
550159-K	ZCL-1.0-40-A12-K	1.0	40	40	42	25	12	4	13.8 +0.1	30	15	9.8	29
550169-K	ZCL-1.0-45-A15-K	1.0	45	45	47	25	15	5	17.3 +0.1	35	15	11.1	37

ZCL-1.5-K

Code	Description	Module M	No. of teeth Z	Dp*	D	L	dH9	bD10	t1	d1	d2	l1	Max. torque [Nm]	
550317-K	ZCL-1.5-20-A12-K	1.5	20	30	33	30	12	4	13.8 +0.1	25	-	17	11.4	23
550321-K	ZCL-1.5-22-A12-K	1.5	22	33	36	30	12	4	13.8 +0.1	28	-	17	12.5	25
550325-K	ZCL-1.5-24-A12-K	1.5	24	36	39	30	12	4	13.8 +0.1	28	-	17	13.7	28
550327-K	ZCL-1.5-25-A12-K	1.5	25	37.5	40.5	30	12	4	13.8 +0.1	30	-	17	14.2	34
550337-K	ZCL-1.5-30-A15-K	1.5	30	45	48	30	15	5	17.3 +0.1	35	-	17	17.1	45
550341-K	ZCL-1.5-32-A15-K	1.5	32	48	51	30	15	5	17.3 +0.1	35	-	17	18.2	49
550345-K	ZCL-1.5-34-A15-K	1.5	34	51	54	30	15	5	17.3 +0.1	35	-	17	19.4	54
550357-K	ZCL-1.5-40-A20-K	1.5	40	60	63	30	20	6	22.8 +0.1	40	48	17	22.8	64
550373-K	ZCL-1.5-50-A20-K	1.5	50	75	78	30	20	6	22.8 +0.1	45	53	17	28.5	111

* Pitch diameter.

- 1
- 2
- 3
- 4
- 5
- 6
- 7
- 8
- 9
- 10
- 11
- 12
- 13
- 14
- 15
- 16
- 17
- 18

ZCL-2.0-K (Z ≤ 30)
 ZCL-2.5-K (Z ≤ 25)
 ZCL-3.0-K (Z ≤ 25)

ZCL-2.0-K (Z ≥ 35)
 ZCL-2.5-K (Z ≥ 30)
 ZCL-3.0-K (Z ≥ 30)

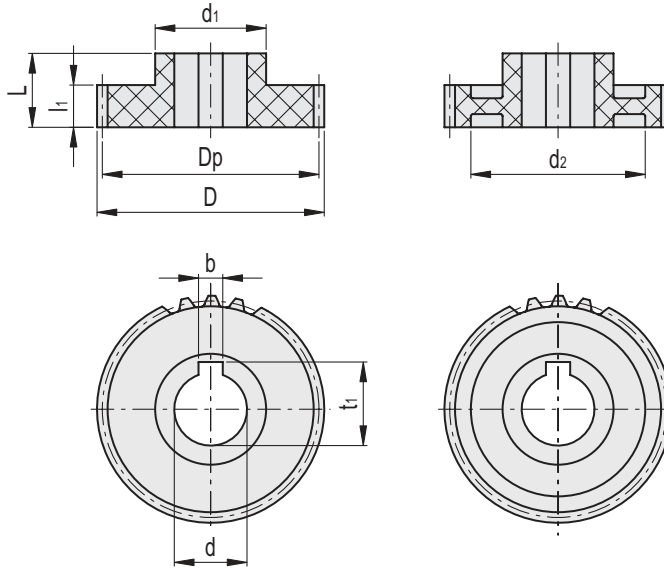

Conversion Table	
1 mm = 0.039 inch	
mm	inch
35	1.38
40	1.57
45	1.77

METRIC

ZCL-2.0-K

Code	Description	Module M	No. of teeth Z	Dp*	D	L	dH9	bD10	t1	d1	d2	l1	Max. torque [Nm]	
550507-K	ZCL-2.0-15-A10-K	2.0	15	30	34	35	10	3	11.4 +0.1	22	-	20	19.4	23
550509-K	ZCL-2.0-16-A12-K	2.0	16	32	36	35	12	4	13.8 +0.1	25	-	20	20.7	29
550513-K	ZCL-2.0-18-A12-K	2.0	18	36	40	35	12	4	13.8 +0.1	30	-	20	23.2	34
550517-K	ZCL-2.0-20-A12-K	2.0	20	40	44	35	12	4	13.8 +0.1	30	-	20	25.8	42
550521-K	ZCL-2.0-22-A12-K	2.0	22	44	48	35	12	4	13.8 +0.1	30	-	20	28.4	49
550525-K	ZCL-2.0-24-A15-K	2.0	24	48	52	35	15	5	17.3 +0.1	35	-	20	31.0	56
550527-K	ZCL-2.0-25-A15-K	2.0	25	50	54	35	15	5	17.3 +0.1	35	-	20	32.3	66
550537-K	ZCL-2.0-30-A15-K	2.0	30	60	64	35	15	5	17.3 +0.1	40	-	20	38.7	83
550547-K	ZCL-2.0-35-A20-K	2.0	35	70	74	35	20	6	22.8 +0.1	45	51	20	45.2	113
550557-K	ZCL-2.0-40-A20-K	2.0	40	80	84	35	20	6	22.8 +0.1	55	66	20	51.6	138
550577-K	ZCL-2.0-50-A25-K	2.0	50	100	104	35	25	8	28.3 +0.2	60	84	20	64.6	209
550597-K	ZCL-2.0-60-A25-K	2.0	60	120	124	35	25	8	28.3 +0.2	60	101	20	77.5	238

ZCL-2.5-K

550701-K	ZCL-2.5-12-A10-K	2.5	12	30	35	40	10	3	11.4 +0.1	22	-	25	30.3	26
550707-K	ZCL-2.5-16-A12-K	2.5	16	40	45	40	12	4	13.8 +0.1	30	-	25	40.3	46
550715-K	ZCL-2.5-20-A15-K	2.5	20	50	55	40	15	5	17.3 +0.1	35	-	25	50.4	73
550719-K	ZCL-2.5-22-A20-K	2.5	22	55	60	40	20	6	22.8 +0.1	40	-	25	55.5	90
550723-K	ZCL-2.5-24-A20-K	2.5	24	60	65	40	20	6	22.8 +0.1	40	-	25	60.5	96
550725-K	ZCL-2.5-25-A20-K	2.5	25	62.5	67.5	40	20	6	22.8 +0.1	40	-	25	63.0	109
550735-K	ZCL-2.5-30-A20-K	2.5	30	75	80	40	20	6	22.8 +0.1	45	56	25	75.6	147
550755-K	ZCL-2.5-40-A20-K	2.5	40	100	105	40	20	6	22.8 +0.1	50	73	25	100.9	233

ZCL-3.0-K

550801-K	ZCL-3.0-12-A12-K	3.0	12	36	42	45	12	4	13.8 +0.1	25	-	30	52.3	43
550807-K	ZCL-3.0-15-A12-K	3.0	15	45	51	45	12	4	13.8 +0.1	30	-	30	65.4	70
550809-K	ZCL-3.0-16-A15-K	3.0	16	48	54	45	15	5	17.3 +0.1	35	-	30	69.7	82
550817-K	ZCL-3.0-20-A20-K	3.0	20	60	66	45	20	6	22.8 +0.1	45	-	30	87.1	135
550827-K	ZCL-3.0-25-A20-K	3.0	25	75	81	45	20	6	22.8 +0.1	45	-	30	108.9	175
550837-K	ZCL-3.0-30-A20-K	3.0	30	90	96	45	20	6	22.8 +0.1	50	65	30	130.7	236
550855-K	ZCL-3.0-40-A25-K	3.0	40	120	126	45	25	8	28.3 +0.2	60	85	30	174.3	322
550875-K	ZCL-3.0-50-A25-K	3.0	50	150	156	45	25	8	28.3 +0.2	60	127	30	217.9	400

Standard machine parts

* Pitch diameter.