

1

2

3

4

5

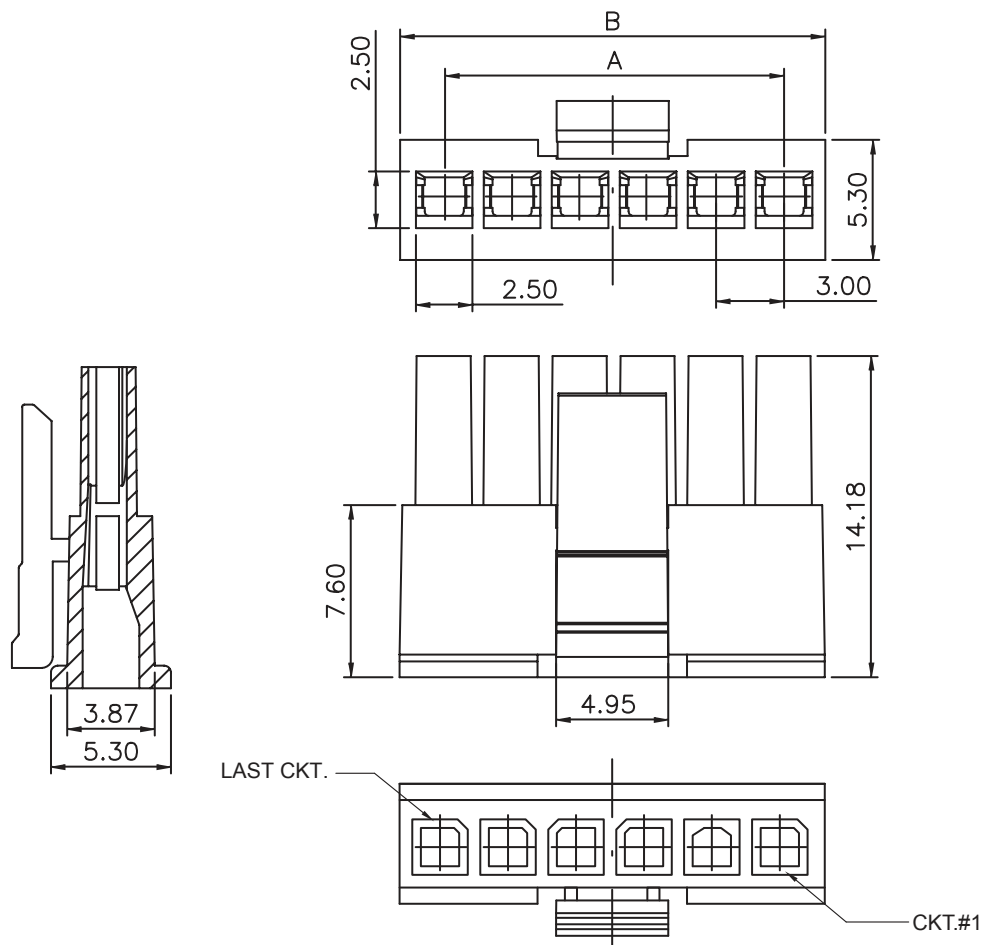

TECHNICAL CHARACTERISTICS

MATERIAL
INSULATOR: NYLON 66
COLOR: BLACK
PITCH: 3.00MM

ENVIRONMENTAL
OPERATING TEMPERATURE: -25 UP TO 105°C
FLAMABILITY RATING: UL94-V0
COMPLIANCE: LEAD FREE AND ROHS

ELECTRICAL
CURRENT RATING: 5A
WORKING VOLTAGE: 250V AC
INSULATOR RESISTANCE: >1000 MOHM
DIELECTRIC WITHSTANDING VOLTAGE: 1500V AC/MN

STANDARD
 CERTIFIED: E323964

PACKAGING
BAG

DIMENSION
A = 3.00 x (NB. PIN - 1)
B = 3.00 x (NB. PIN) + 0.85

RoHS Compliant

PROJECTION:



GENERAL TOLERANCE

.X = ± 0.2 .XX = ± 0.15 

APPROVAL: BBu

UNIT: MM

SCALE:

SHEET: 1/3

DRAW: AS

DESCRIPTION: WR-MPC3 - 3.00MM FEMALE SINGLE ROW RECEPTACLE

WERI PART NO: 662 0xx 013 322

SIZE

A4

J							
I							
H	02-JUL-15	PINNING	AK				
REV	DATE	FILE	BY				

1

2

3

4

5

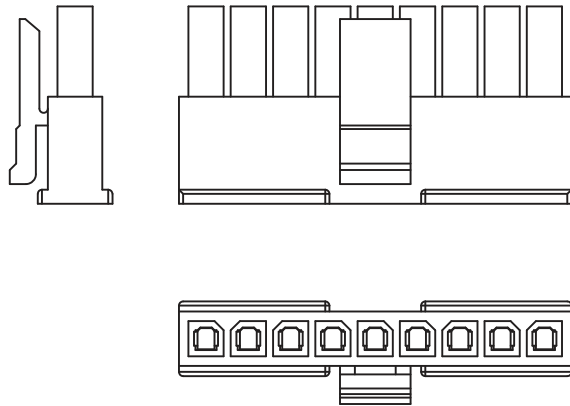

Note:
 1.Dimension:
 Carton Size:40*28*28(cm)
 2.Quantity:

Pin.	Pcs/Bag	Pcs/Carton	Pin.	Pcs/Bag	Pcs/Carton
2	1000	14000	8	500	5000
3	1000	14000	9	500	5000
4	1000	10000	10	250	3500
5	1000	10000	11	250	2500
6	1000	6000	12	250	2500
7	500	6000			

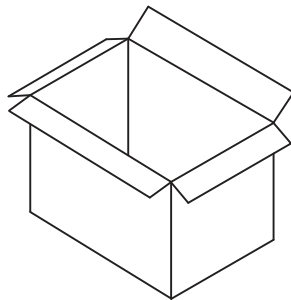
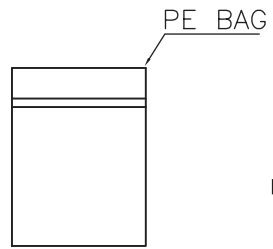

Carton

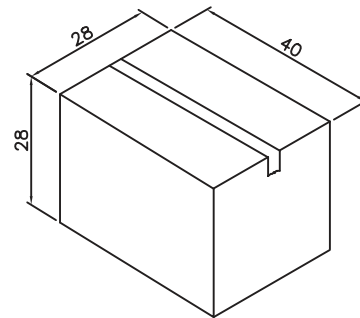

RoHS Compliant			
G			
F			
E			
D			
C			
B			
A			
REV	DATE	FILE	BY

PROJECTION:

APPROVAL: BBu

GENERAL TOLERANCE
 .X = +/- 0.2
 .XX = +/- 0.15

UNIT: MM
 SCALE:
 SHEET: 2/3
 DRAW: AS



DESCRIPTION: WR-MPC3 - 3.00MM FEMALE SINGLE ROW RECEPTACLE
 WERI PART NO: 662 0xx 013 322_TPK

SIZE
A4

A

B

C

D

1

2

3

4

5

Cautions and Warnings:

This electronic component is designed and developed with the intention for use in general electronics equipments.

Before incorporating the components into any equipments in the field such as aerospace, aviation, nuclear control, submarine, transportation, (automotive control, train control, ship control), transportation signal, disaster prevention, medical, public information network etc. where higher safety and reliability are especially required or if there is possibility of direct damage or injury to human body, Würth Elektronik must be asked for a written approval.



In addition, even electronic component in general electronic equipments, when used in electrical circuits that require high safety, reliability functions or performance, the sufficient reliability evaluation-check for the safety must be performed before by the user before usage.

A

B

C

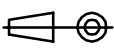
RoHS Compliant

G				PROJECTION: 	GENERAL TOLERANCE .X = +/- 0.2 .XX = +/- 0.15		
F							
E							
D							
C				APPROVAL: JC	UNIT: MM	DESCRIPTION: DISCLAIMER	SIZE A4
B					SCALE:		
A	10-SEP-14	PDF	QL		SHEET: 3/3	WERI PART NO: DISCLAIMER	
REV	DATE	FILE	BY		DRAW: QL		

D